

15803

RAM 3500 SHORT AND LONG BOX

GROSS LOAD CAPACITY WHEN USED AS A WEIGHT CARRYING HITCH: 20,000 LBS. TRAILER WEIGHT & 2,700 LBS. TONGUE WEIGHT.  
 GROSS LOAD CAPACITY WHEN USED AS A WEIGHT DISTRIBUTION HITCH: 20,000 LBS. TRAILER WEIGHT & 2,700 LBS. TONGUE WEIGHT  
**\*\*\*DO NOT EXCEED VEHICLE MANUFACTURER'S RECOMMENDED TOWING CAPACITY.\*\*\***

Parts List			
ITEM	QTY	PART NUMBER	DESCRIPTION
1	2	9/16-12 x 2	HEX BOLT
2	2	9_16 FISHWIRE	9/16" FISHWIRE
3	2	9_16 WASHER USS FLAT	FLAT WASHER
4	6	9_16-12 FLANGE NUT	HEX FLANGE NUT
5	4	9_16-12 x 1 3/4	CARRIAGE BOLT
6	4	CM-SP74	.313 x 1.50 x 3.00" 9/16" SQUARE HOLE SPACER
7	6	CM-SP8	.188 x 1.25 x 1.50" ROUND HOLE SPACER

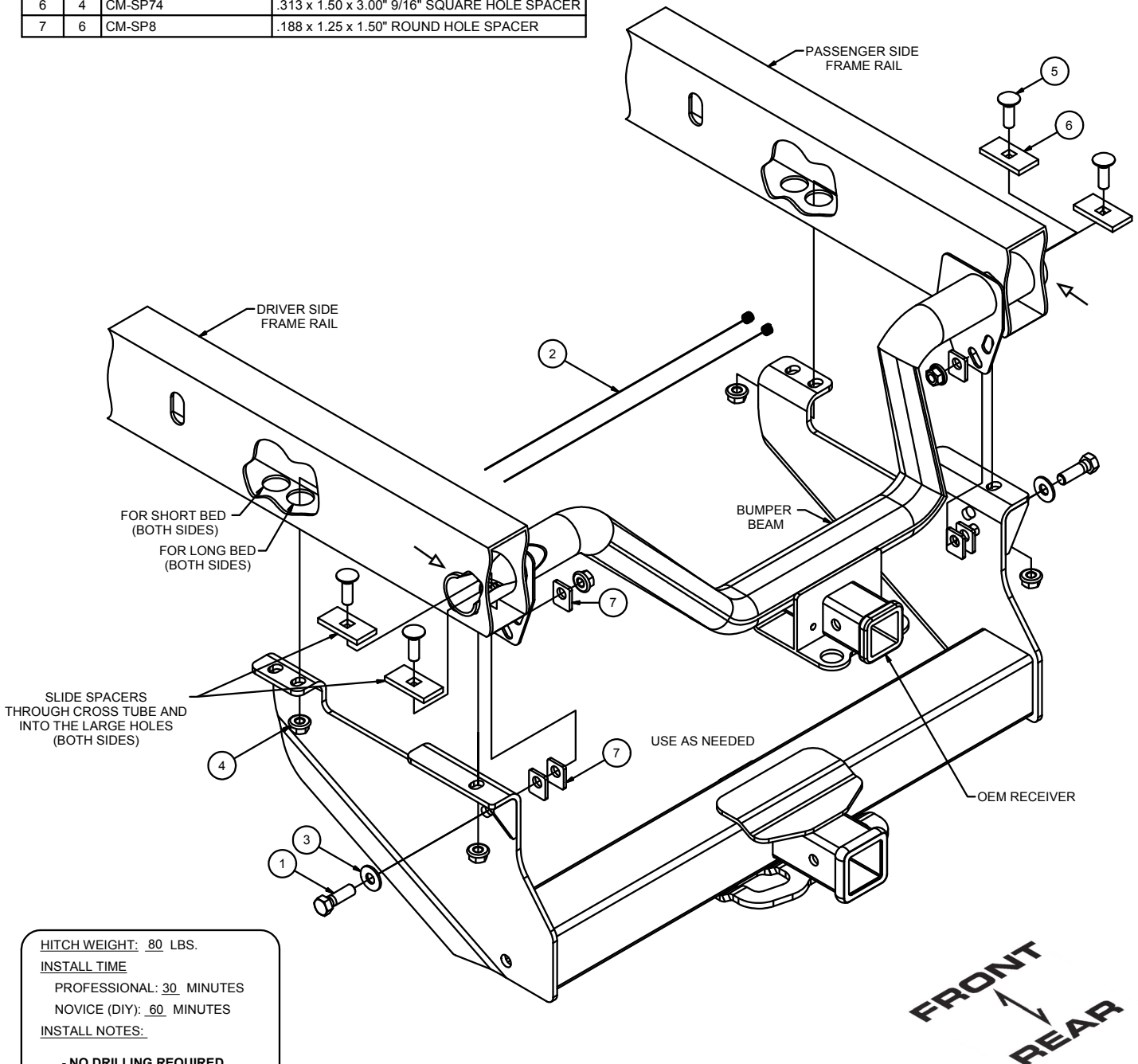

HITCH WEIGHT: 80 LBS.

INSTALL TIME

PROFESSIONAL: 30 MINUTES

NOVICE (DIY): 60 MINUTES

INSTALL NOTES:

- NO DRILLING REQUIRED
- FISHWIRE HARDWARE

**PERIODICALLY CHECK THIS RECEIVER HITCH TO ENSURE THAT ALL FASTENERS ARE TIGHT AND THAT ALL STRUCTURAL COMPONENTS ARE SOUND.**

CURT Manufacturing LLC., warrants this product to be free of defects in material and/or workmanship at the time of retail purchase by the original purchaser. If the product is found to be defective, CURT Manufacturing LLC., may repair or replace the product, at their option, when the product is returned, prepaid, with proof of purchase. Alteration to, misuse of, or improper installation of this product voids the warranty. CURT Manufacturing LLC.'s liability is limited to repair or replacement of products found to be defective, and specifically excludes liability for incidental or consequential loss or damage.

**15803****RAM 3500 SHORT AND LONG BOX**

GROSS LOAD CAPACITY WHEN USED AS A WEIGHT CARRYING HITCH: 20,000 LBS. TRAILER WEIGHT & 2,700 LBS. TONGUE WEIGHT.  
 GROSS LOAD CAPACITY WHEN USED AS A WEIGHT DISTRIBUTION HITCH: 20,000 LBS. TRAILER WEIGHT & 2,700 LBS. TONGUE WEIGHT

**\*\*\*DO NOT EXCEED VEHICLE MANUFACTURER'S RECOMMENDED TOWING CAPACITY.\*\*\***

**FISHWIRE TECHNIQUE**

INSERT COILED END OF FISHWIRE TOOL THROUGH HITCH MOUNTING HOLE IN VEHICLE FRAME RAIL AND OUT THE ACCESS HOLE. PASS COILED END OF FISHWIRE THROUGH SPACER AND THREAD BOLT INTO COIL. KINK WIRE TO KEEP SPACER SEPARATE FROM BOLT AS SHOWN. PULL FISHWIRE, SPACER, AND BOLT THROUGH FRAME AND OUT MOUNTING HOLE. USE FISHWIRE TO GUIDE HITCH DURING MOUNTING AND PREVENT LOSS OF BOLT / SPACER INSIDE FRAME RAIL.

\*\*NOTE: SOME VEHICLES MAY FISHWIRE THROUGH END OF FRAME\*\*

**TOOLS REQUIRED**

SOCKET WRENCH

TORQUE WRENCH

8 in. SOCKET EXTENSION

13/16" &amp; 7/8" SOCKET

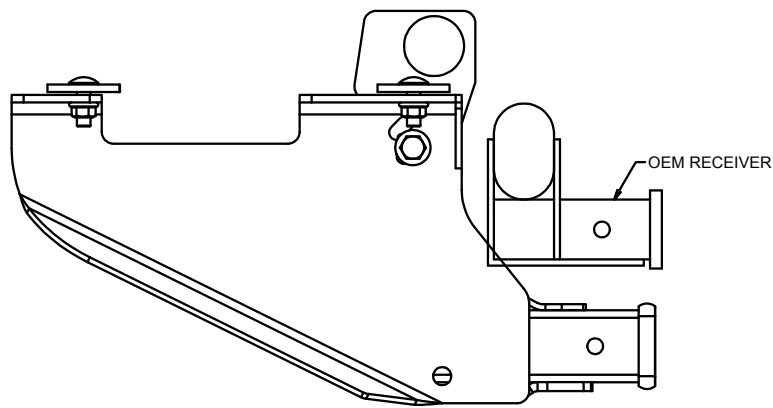
**INSTALLED HITCH POSITION****INSTALLATION STEPS**

1. Raise hitch into position by aligning holes in hitch side plates with holes in frame rails. **Note:** Hole alignment will depend on vehicle bed length. Long bed vehicles will use front most hole and short bed vehicles will use the middle hole on hitch side plates. **Note:** If equipped with factory hitch, you may need to loosen the hitch/bumper beam and push it towards the rear of vehicle to create additional space for the CURT hitch.
2. Fishwire 9/16" carriage bolts and CM-SP74 spacers through the ends of the cross tube and the large hole in the frame rails. Do this for both the forward and rear attachment points in the frame rail. (See FISHWIRE TECHNIQUE diagram.)  
**Note:** Hole alignment will depend on vehicle bed length. Long bed vehicles will use front most hole and short bed vehicles will use the middle hole on hitch side plates.
3. Secure hitch with 9/16" hex flange nuts onto carriage bolts.
4. Install 9/16" hex bolts and flat washers through hitch side plates and tow loops, as shown.
5. Install enough CM-SP8 spacers between tow loops and hitch side plates to prevent the tow loops from pulling into hitch when the hex bolts are tightened.
6. Torque previously installed carriage bolts to 150 lb-ft.
7. Secure hex bolts with CM-SP8 spacers and 9/16" hex flange nuts, as shown.
8. Torque remaining 9/16" hardware to 150 lb-ft.

**PERIODICALLY CHECK THIS RECEIVER HITCH TO ENSURE THAT ALL FASTENERS ARE TIGHT AND THAT ALL STRUCTURAL COMPONENTS ARE SOUND.**

CURT Manufacturing LLC., warrants this product to be free of defects in material and/or workmanship at the time of retail purchase by the original purchaser. If the product is found to be defective, CURT Manufacturing LLC., may repair or replace the product, at their option, when the product is returned, prepaid, with proof of purchase. Alteration to, misuse of, or improper installation of this product voids the warranty. CURT Manufacturing LLC.'s liability is limited to repair or replacement of products found to be defective, and specifically excludes liability for incidental or consequential loss or damage.