

YEARS: 2019-PRESENT

MAKE: CHEVROLET / GMC

MODEL: 1500 SILVERADO / 1500 SIERRA

STYLE: PICKUP

WARNING: NEVER EXCEED YOUR VEHICLE MANUFACTURER'S RECOMMENDED TOWING CAPACITY

WEIGHT CARRYING:
 TRAILER WEIGHT: 16,000 LBS.
 TONGUE WEIGHT: 2,400 LBS.

WEIGHT DISTRIBUTION:
 TRAILER WEIGHT: 17,000 LBS.
 TONGUE WEIGHT: 2,400 LBS.

PRO INSTALL TIME: 75 MIN.
NOVICE INSTALL TIME: 120 MIN.

IF YOU ARE HESITANT TO UNDERTAKE THIS TASK ON YOUR OWN, CONTACT AN AUTHORIZED CURT INSTALLER FOR ADDITIONAL ASSISTANCE.

INSTALLATION TIPS:

- BEFORE YOU BEGIN INSTALLATION, READ ALL INSTRUCTIONS THOROUGHLY.
- TO EASE INSTALLATION, 2 PEOPLE MAY BE REQUIRED.
- USING PROPER TOOLS WILL GREATLY IMPROVE THE QUALITY OF THE INSTALL AND REDUCE THE TIME REQUIRED.



INSTALLATION REQUIRES:

RATCHET	TORQUE WRENCH	6" SOCKET EXTENSION
10mm 15mm 21mm 7/8" SOCKET	SAFETY GLASSES	

LEVEL OF DIFFICULTY: MODERATE

EASY	MODERATE	CHALLENGING
NO DRILLING REQUIRED		
TEMPORARILY LOWER SPARE TIRE		
TEMPORARILY LOWER EXHAUST AND EXHAUST BEZEL (DUAL EXHAUST MODELS ONLY)		

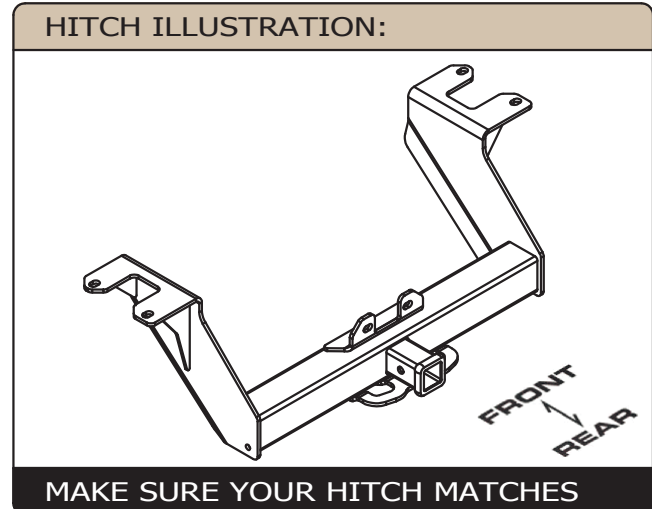

PERIODICALLY CHECK THIS RECEIVER HITCH TO ENSURE ALL FASTENERS ARE TIGHT AND ALL STRUCTURAL COMPONENTS ARE SOUND
 CURT Manufacturing LLC. warrants this product to be free of defects in material and/or workmanship at the time of retail purchase by the original purchaser. If the product is found to be defective, CURT Manufacturing LLC. may repair or replace the product at their option, when the product is returned, prepaid, with proof of purchase. Alteration to, misuse of, or improper installation of this product voids the warranty. CURT Manufacturing LLC.'s liability is limited to repair or replacement of products found to be defective, and specifically excludes liability for incidental or consequential loss or damage.

INSTALLATION WALKTHROUGH:

Parts List			
ITEM	QTY	PART NUMBER	DESCRIPTION
1	2	9/16-12 x 1 3/4, GR8	CARRIAGE BOLT
2	2	9_16-12, GR8	HEX FLANGE NUT
3	2	15307-SP	SPACER

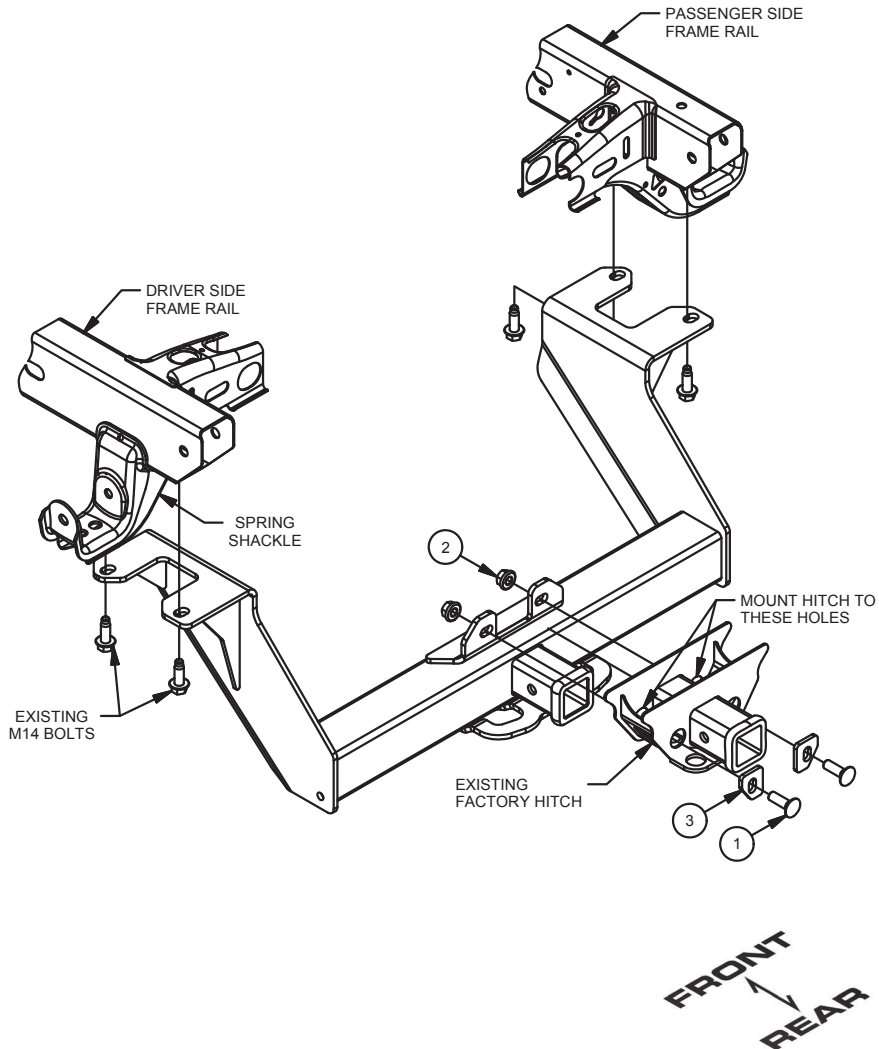

Vehicles with **Dual Exhaust System** (skip to step 3 for **Single Exhaust**)

1. Using a 15mm socket, remove the exhaust hanger bracket on the driver side. Remove the passenger side exhaust hanger bracket hardware but leave the bracket on the exhaust hanger.

2. Using a 10mm socket, locate and remove the (3) hex bolts securing the driver side exhaust bezel. Save for reinstallation.

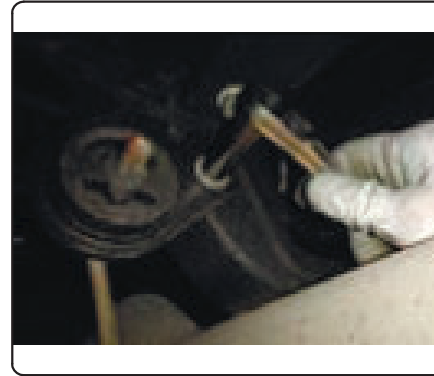

3. Remove the (2) existing hex bolts from the frame on both sides of the vehicle.



INSTALLATION WALKTHROUGH:

4. Raise hitch into position, loosely secure the side plates to the frame using the factory hardware. Move the exhaust out of the way if necessary.

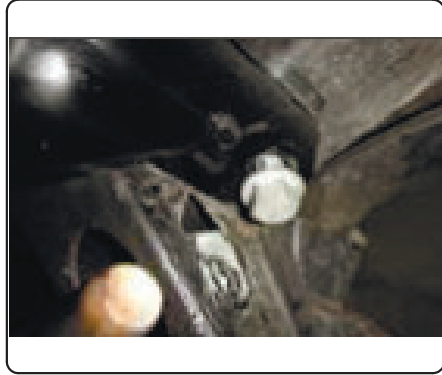

5. Insert (2) 9/16" carriage bolts and 15307-SPs through the factory safety chain plate and top plate of the hitch. Secure the 9/16" carriage bolts using (2) 9/16" hex flange nuts.

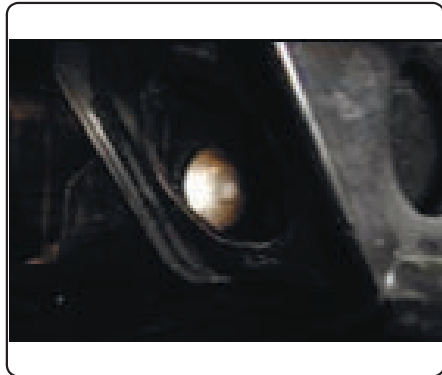

6. Torque the factory hardware to 126 ft-lbs and the 9/16" hardware to 130 ft-lbs.

7. Re-install exhaust hanger brackets removed in step 1 and bezel removed in step 2.

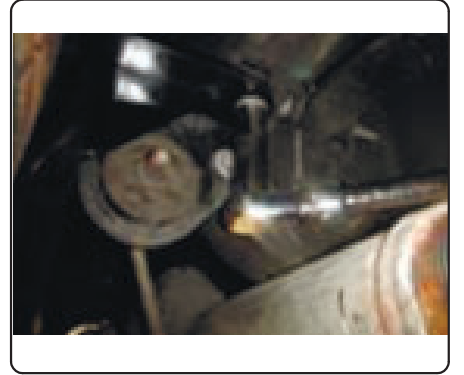

TOWING SAFETY INFORMATION

Gross Trailer Weight / GTW

The Gross Trailer Weight is the weight of the trailer & cargo. Measure this by putting the fully loaded trailer on a vehicle scale.

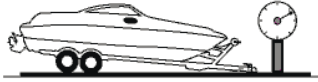

Tongue Weight / TW

The downward force that is exerted on the hitch ball by the coupler. The tongue weight will vary depending on where the load is positioned in relationship to the trailer axle(s). To measure the tongue weight, use either a commercial scale or a bathroom scale with the coupler at towing height. When using a bathroom scale with heavier tongue weights, use the method shown and multiply the scale reading by 3.

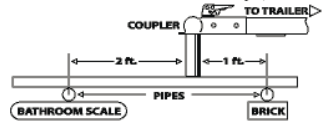

Weight Carrying / WC

The total weight of both the trailer and the cargo inside. Never exceed the weight capacity of your trailer hitch.

Weight Distribution / WD

Used to balance the weight of the cargo between the front and rear wheels throughout the trailer, allowing for better steering, braking, and level riding.



Sway Control

A device used to reduce the lateral movements of the trailer that are caused by the wind. This works in conjunction with a weight distribution hitch. Do not use this on a class 1 or 2 hitch, or with surge brakes.

How Much Can You Safely Tow?

TONGUE WEIGHT lbs.	1000	2000	3000	4000	5000	6000	7000	8000	10,000	12,000
CLASS 1	[Bar]									
CLASS 2	[Bar]									
CLASS 3	[Bar]									
CLASS 4	[Bar]									
CLASS 5	[Bar]									
TRAILER TYPE										
Camper	11'	12'	13'	14'	15'	16'				
lbs.	1100	1200	1300	1400	1500	1600				
Vacation	14'	16'	18'	20'	22'	24'	26'	28'	30'	32'
lbs.	2100	2400	2700	3000	3300	3600	3900	4200	4500	4800
Vacation	14'	16'	18'	20'	22'	24'	26'	28'	30'	32'
lbs.	2800	3200	3600	4000	4400	4800	5200	5600	6000	6400
5th Wheel										

Refer to owner's manual for towing capabilities and limitations.

Ball Mount

The ball mount is placed inside the opening of the receiver hitch which is mounted to the vehicle. Make sure a hitch pin and clip is properly securing the ball mount to the receiver hitch before you begin towing.

- A: Rise. B: Drop. C: Hole Size. D: Length.

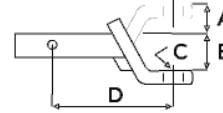

Trailer Ball

The connection from the hitch to the trailer. There are many factors that determine the correct hitch ball:

- Number one is the hitch ball's gross trailer weight rating.
- The mounting platform must be at least 3/8" thick.
- The hole diameter must not be more than 1/16" larger than the threaded shank.
- Every time you tow, check the nut and lock washer to make sure they are fastened securely.

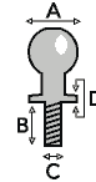

Coupler

The component that is placed over the trailer ball to connect the vehicle to the trailer. Be sure that the coupler size matches the size of the hitch ball and that the coupler handle is securely fastened. To determine what size hitch ball you need for your application you will need to know the size of coupler that is on the trailer. Be sure your coupler is properly adjusted to the ball you are using.

NOTE: For added security the use of safety devices such as Coupler Safety Pins and Locks is strongly recommended.

Safety Chains

Safety chains are a requirement and should be crossed under the tongue of the trailer so that the tongue will not drop to the road if it becomes separated from the hitch. Always leave enough slack so you can turn. Never allow the safety chains to drag on the ground and never attach the chains to the bumper.

Trailer Classification: Safety Chain Breaking Force - Minimum

- Class 1: 2,000 lbs. (8.9 kN)
- Class 2: 3,500 lbs. (15.6 kN)
- Class 3: 5,000 lbs. (22.2 kN)

The strength rating of each length of safety chain or its equivalent and its attachments shall be equal to or exceed in minimum breaking force the GVWR (Gross Vehicle Weight Rating) of the trailer.

Electrical

Trailer lights, Electric Brakes, Break-away systems - Every time you tow, be sure to check that all components are working properly.

Wiring identification by color:



CURT DISCLAIMER: WIRING COLOR SHOWN WORK IN CONJUNCTION WITH CURT MANUFACTURING PRODUCTS.

15307**CHEVROLET SILVERADO 1500 / GMC SIERRA 1500**

1/31/2019

GROSS LOAD CAPACITY WHEN USED AS A WEIGHT CARRYING HITCH: 16,000 LBS. TRAILER WEIGHT & 2,400 LBS. TONGUE WEIGHT.
 GROSS LOAD CAPACITY WHEN USED AS A WEIGHT DISTRIBUTION HITCH: 17,000 LBS. TRAILER WEIGHT & 2,400 LBS. TONGUE WEIGHT



WARNING: * DO NOT EXCEED VEHICLE MANUFACTURER'S RECOMMENDED TOWING CAPACITY. *****



Parts List			
ITEM	QTY	PART NUMBER	DESCRIPTION
1	2	9/16-12 x 1 3/4, GR8	CARRIAGE BOLT
2	2	9_16-12, GR8	HEX FLANGE NUT
3	2	15307-SP	SPACER

TOOLS REQUIRED	
10mm, 15mm, 21mm, 7/8" Socket	
Ratchet	
6" Extension	
Torque Wrench	

HITCH WEIGHT: 64 LBS.

INSTALL TIME

PROFESSIONAL: 120 MINUTES

NOVICE (DIY): 75 MINUTES

INSTALL NOTES:

- NO TRIMMING REQUIRED
- NO DRILLING REQUIRED
- MAY NEED TO LOWER EXHAUST, EXHAUST BEZEL AND SPARE TIRE

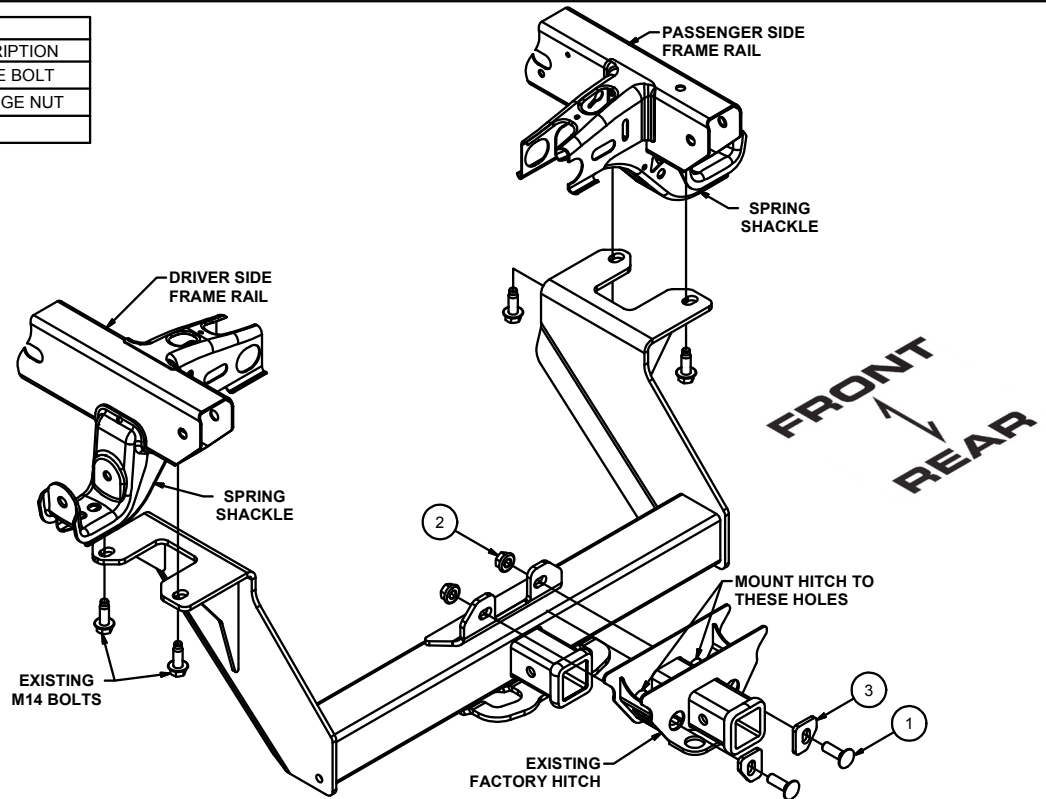

INSTALLATION STEPS

Vehicles with Single Exhaust System

1. Remove the (2) existing hex bolts from the frame on both sides of the vehicle.
2. Raise hitch into position, loosely secure the side plates to the frame using the factory hardware.
3. Insert (2) 9/16" carriage bolts and 15307-SPs through the factory safety chain plate and top plate of the hitch. Secure the 9/16" carriage bolts using (2) 9/16" hex flange nuts.
4. Torque the factory hardware to 126 ft-lbs and the 9/16" hardware to 130 ft-lbs.

Vehicles with Dual Exhaust System

1. Using a 15mm socket, remove the exhaust hanger bracket on the driver side. Remove the passenger side exhaust hanger bracket hardware but leave the bracket on the exhaust hanger.
2. Using a 10mm socket, locate and remove the (3) hex bolts securing the driver side exhaust bezel. Save for reinstallation.
3. Remove the (2) existing hex bolts from the frame on both sides of the vehicle.
4. Raise hitch into position, loosely secure the side plates to the frame using the factory hardware. Move the exhaust out of the way if necessary.
5. Insert (2) 9/16" carriage bolts and 15307-SPs through the factory safety chain plate and top plate of the hitch. Secure the 9/16" carriage bolts using (2) 9/16" hex flange nuts.
6. Torque the factory hardware to 126 ft-lbs and the 9/16" hardware to 130 ft-lbs.
7. Re-install exhaust hanger brackets removed in step 1 and bezel removed in step 2.

PERIODICALLY CHECK THIS RECEIVER HITCH TO ENSURE THAT ALL FASTENERS ARE TIGHT AND THAT ALL STRUCTURAL COMPONENTS ARE SOUND.

Shop for quality CURT products on our website.

Learn more about trailer hitches and towing we have.