

YEARS: 2019

MAKE: RAM

MODEL: 1500

STYLE: ALL

**WARNING: NEVER EXCEED YOUR VEHICLE MANUFACTURER'S RECOMMENDED TOWING CAPACITY**

**WEIGHT CARRYING:**  
 TRAILER WEIGHT: 15,000 LBS.  
 TONGUE WEIGHT: 1,700 LBS.

**WEIGHT DISTRIBUTION:**  
 TRAILER WEIGHT: 17,000 LBS.  
 TONGUE WEIGHT: 1,700 LBS.

**PRO INSTALL TIME: 60 MIN.**  
**NOVICE INSTALL TIME: 120 MIN.**

IF YOU ARE HESITANT TO UNDERTAKE THIS TASK ON YOUR OWN, CONTACT AN AUTHORIZED CURT INSTALLER FOR ADDITIONAL ASSISTANCE.

**INSTALLATION TIPS:**

- BEFORE YOU BEGIN INSTALLATION, READ ALL INSTRUCTIONS THOROUGHLY.
- TO EASE INSTALLATION, 2 PEOPLE MAY BE REQUIRED.
- USING PROPER TOOLS WILL GREATLY IMPROVE THE QUALITY OF THE INSTALL AND REDUCE THE TIME REQUIRED.

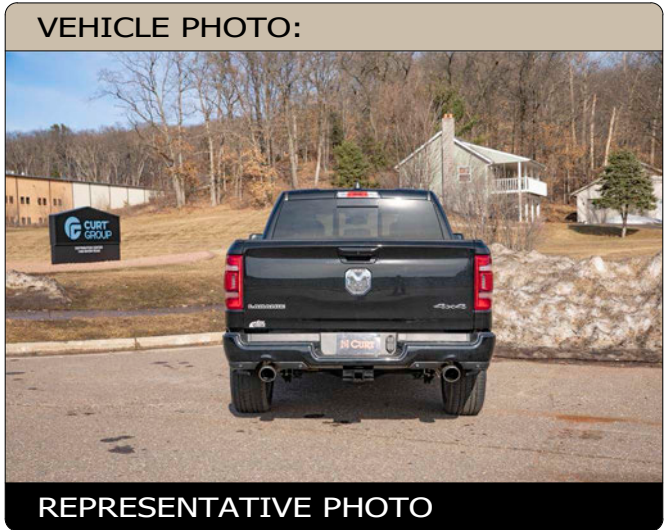

**INSTALLATION REQUIRES:**

RATCHET	6" SOCKET EXTENSION	10mm 15mm 16mm 17mm SOCKET
21mm 22mm 3/4" 7/8" SOCKET	PRY BAR	TORQUE WRENCH
SAFETY GLASSES	HAMMER	

**LEVEL OF DIFFICULTY: EASY**

EASY	MODERATE	CHALLENGING

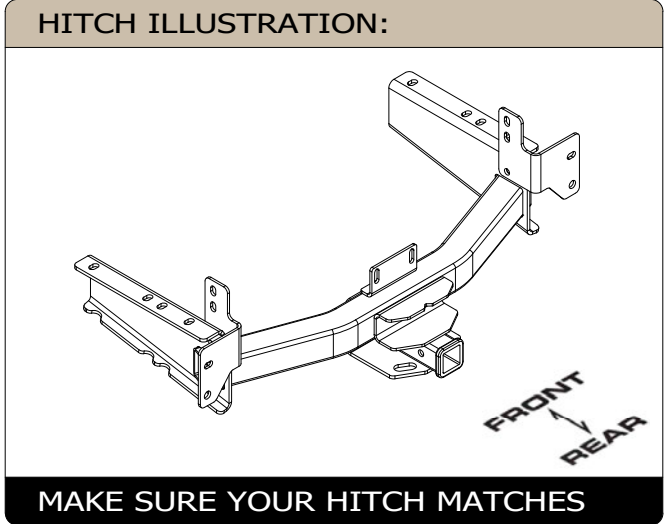

**PERIODICALLY CHECK THIS RECEIVER HITCH TO ENSURE ALL FASTENERS ARE TIGHT AND ALL STRUCTURAL COMPONENTS ARE SOUND**

CURT Manufacturing LLC. warrants this product to be free of defects in material and/or workmanship at the time of retail purchase by the original purchaser. If the product is found to be defective, CURT Manufacturing LLC. may repair or replace the product at their option, when the product is returned, prepaid, with proof of purchase. Alteration to, misuse of, or improper installation of this product voids the warranty. CURT Manufacturing LLC.'s liability is limited to repair or replacement of products found to be defective, and specifically excludes liability for incidental or consequential loss or damage.

## INSTALLATION WALKTHROUGH:

Parts List			
ITEM	QTY	PART NUMBER	DESCRIPTION
1	1	15005-DSBP	DRIVER SIDE BUMPER PLATE
2	1	15005-PSBP	PASSENGER SIDE BUMPER PLATE
3	6	10-10272	BOLT,CAR,1/2-13 UNC,1-3/4,GRD8,YZ
4	2	10-10370	HHCS,1/2-13 UNC,1-3/4,GRD8,YZ
5	2	10-10498	HHCS,M10x1.5,35,CL10.9,YZ
6	8	20-00062	NUT, SER-FLANGE,1/2-13 UNC,GRD8,YZ
7	6	20-00164	NUT,FLANGE,M10x1.5,CL10,YZ
8	4	20-00190	NUT,FLANGE,M14x2,CL10,YZ
9	4	30-00131	WASHER,FLAT,5/8,YZ
10	2	30-00149	WASHER,S-CON,1/2,YZ
11	6	CM-SP1	.250 x 1.50 x 2.00" SQUARE HOLE SPACER
12	6	1_2 FISHWIRE	1/2" FISHWIRE

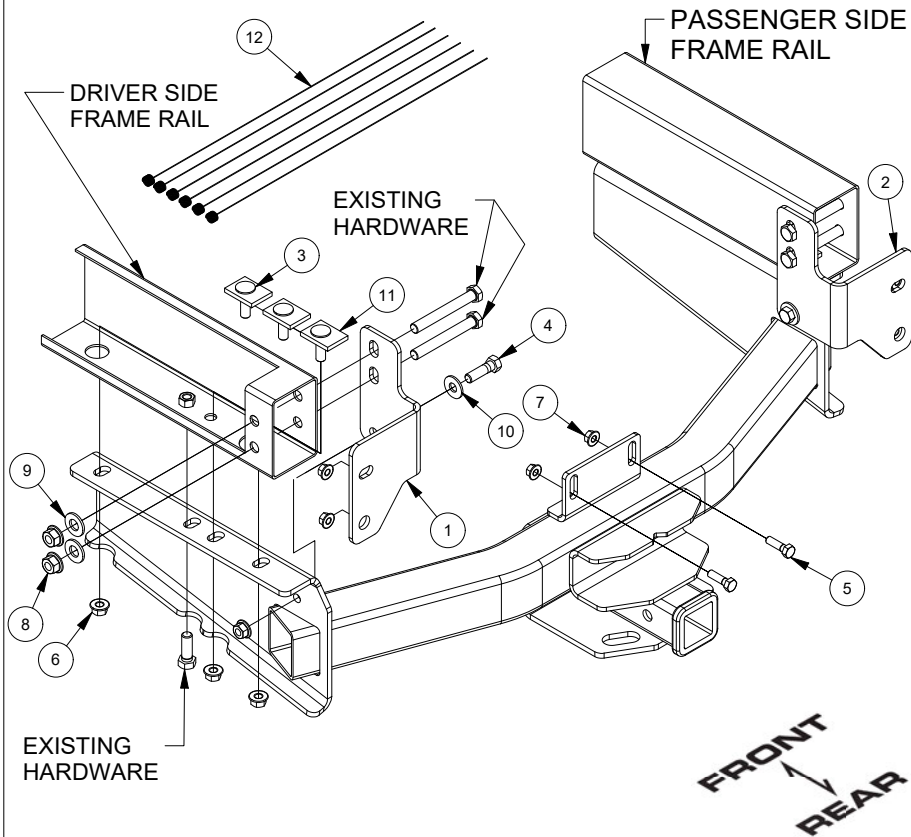

1. Locate and remove the spare tire. Set aside for reinstallation later.



2. On the outside of the driver side frame, unplug the electrical connector. Remove the plastic wiring connectors from the factory hitch.



## INSTALLATION WALKTHROUGH:

3. Remove the (2) factory M10 hex nuts located behind the license plate. While supporting the bumper, locate and remove the (4) factory M10 hex nuts from the bumper beam. Set bumper aside for reinstallation.

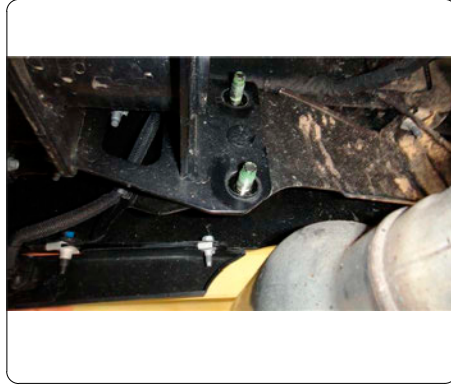

4. Locate and remove the (3) factory M14 bolts on the outside of the driver side frame rail and (1) M14 from the underside of the frame. Repeat on the passenger side frame rail to remove the factory hitch. Save hardware for reinstallation.

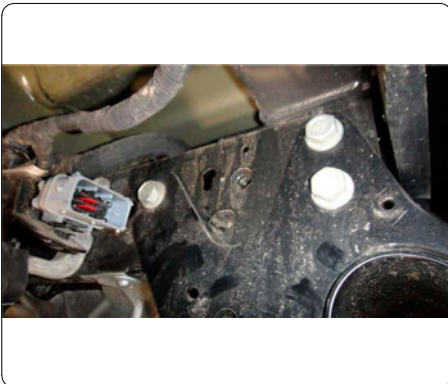

5. Remove (2) factory M6 bolts from the passenger side and (1) M6 bolt on the driver side from the exhaust heat shield. Using a hammer, flatten the heat shield tabs against the frame, heat shield tabs will be pinched between the hitch side plates and the frame.



6. Fishwire the 1/2" carriage bolts and spacers in through the end of the frame rail to the three mounting holes on both frame rails.

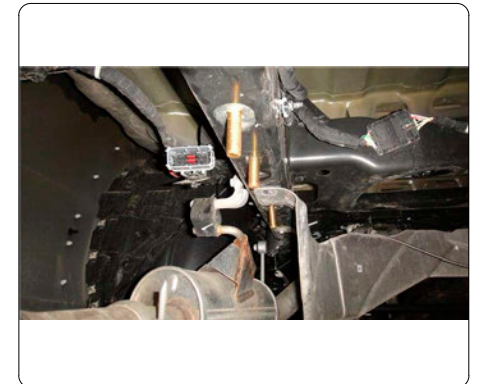
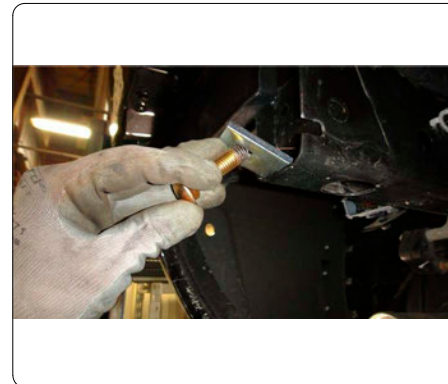



## INSTALLATION WALKTHROUGH:

7. Raise hitch into position. Secure hitch to the vehicle frame using 1/2" hex flange nuts. Reinstall short factory M14 bolt removed earlier to finish securing the hitch to the frame on each side of the frame.

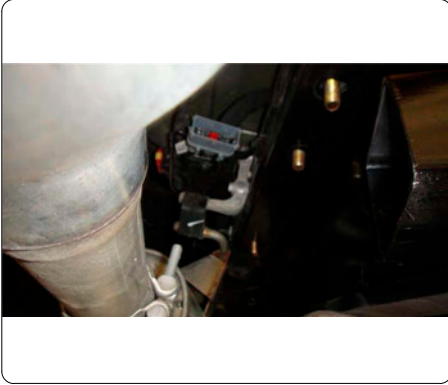

8. Align the driver side bumper bracket with the (2) inside mounting holes on the frame. Secure the bracket to the frame using the long factory M14 bolts removed earlier and (2) M14 hex flange nuts. Repeat on the passenger side.

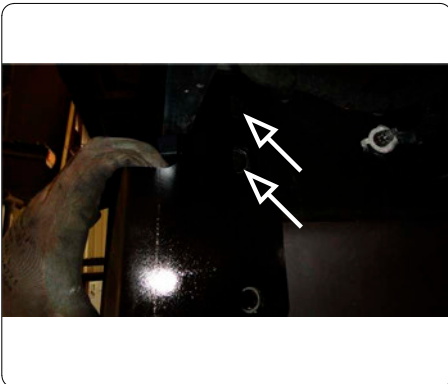

9. Secure the driver side bumper bracket to the hitch using (1) 1/2" hex bolt, (1) conical tooth washer and (1) 1/2" hex flange nut. Repeat on passenger side.

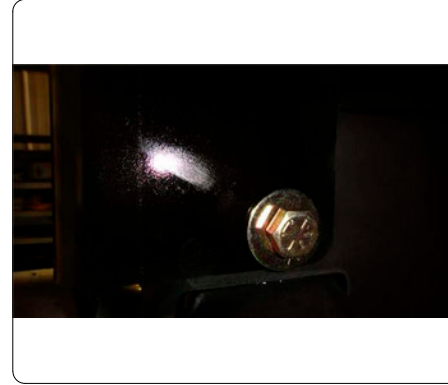

10. Reinstall the bumper, aligning the mounting studs with the mounting holes in the bumper brackets. Secure the bumper to the bumper brackets using (4) M10 hex flange nuts. Secure the center bumper mounts to the bumper plate on the hitch using (2) M10 hex bolts, (2) M10 flat washers and (2) M10 hex flange nuts.



## INSTALLATION WALKTHROUGH:

11. Reinstall the electrical connector and wiring connectors from Step 2. Torque all 1/2" fasteners to 110 ft-lbs and M14 fasteners to 126 ft-lbs.



## TOWING SAFETY INFORMATION

### Gross Trailer Weight / GTW

The Gross Trailer Weight is the weight of the trailer & cargo. Measure this by putting the fully loaded trailer on a vehicle scale.

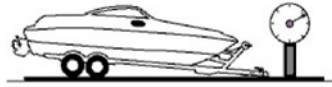

### Tongue Weight / TW

The downward force that is exerted on the hitch ball by the coupler. The tongue weight will vary depending on where the load is positioned in relationship to the trailer axle(s). To measure the tongue weight, use either a commercial scale or a bathroom scale with the coupler at towing height. When using a bathroom scale with heavier tongue weights, use the method shown and multiply the scale reading by 3.

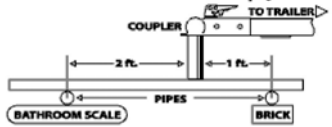

### Weight Carrying / WC

The total weight of both the trailer and the cargo inside. Never exceed the weight capacity of your trailer hitch.

### Weight Distribution / WD

Used to balance the weight of the cargo between the front and rear wheels throughout the trailer, allowing for better steering, braking, and level riding.



### Sway Control

A device used to reduce the lateral movements of the trailer that are caused by the wind. This works in conjunction with a weight distribution hitch. Do not use this on a class 1 or 2 hitch, or with surge brakes.

### How Much Can You Safely Tow?

TONGUE WEIGHT	1000	2000	3000	4000	5000	6000	7000	8000	10,000	12,000
CLASS 1	[Bar]									
CLASS 2	[Bar]									
CLASS 3	[Bar]									
CLASS 4	[Bar]									
CLASS 5	[Bar]									
TRAILER TYPE	11'	12'	13'	14'	15'	16'				
Camper	1100	1200	1300	1400	1500	1600				
Vacation	2100	2400	2700	3000	3300	3600	3900	4200	4500	4800
Vacation	2800	3200	3600	4000	4400	4800	5200	5600	6000	6400
5th Wheel										

*Refer to owner's manual for towing capabilities and limitations.*

### Ball Mount

The ball mount is placed inside the opening of the receiver hitch which is mounted to the vehicle. Make sure a hitch pin and clip is properly securing the ball mount to the receiver hitch before you begin towing.

\* A: Rise. B: Drop. C: Hole Size. D: Length.

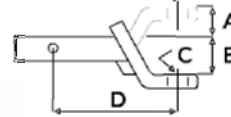

### Trailer Ball

The connection from the hitch to the trailer. There are many factors that determine the correct hitch ball:

- Number one is the hitch ball's gross trailer weight rating.
- The mounting platform must be at least 3/8" thick.
- The hole diameter must not be more than 1/16" larger than the threaded shank.
- Every time you tow, check the nut and lock washer to make sure they are fastened securely.
- A: Ball Dia. B: Shank Length. C: Shank Dia. D: Shank Rise.

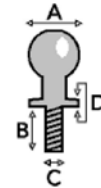

### Coupler

The component that is placed over the trailer ball to connect the vehicle to the trailer. Be sure that the coupler size matches the size of the hitch ball and that the coupler handle is securely fastened. To determine what size hitch ball you need for your application you will need to know the size of coupler that is on the trailer. Be sure your coupler is properly adjusted to the ball you are using.

NOTE: For added security the use of safety devices such as Coupler Safety Pins and Locks is strongly recommended.

### Safety Chains

Safety chains are a requirement and should be crossed under the tongue of the trailer so that the tongue will not drop to the road if it becomes separated from the hitch. Always leave enough slack so you can turn. Never allow the safety chains to drag on the ground and never attach the chains to the bumper.

Trailer Classification: Safety Chain Breaking Force - Minimum

Class 1: 2,000 lbs. (8.9 kN)

Class 2: 3,500 lbs. (15.6 kN)

Class 3: 5,000 lbs. (22.2 kN)

The strength rating of each length of safety chain or its equivalent and its attachments shall be equal to or exceed in minimum breaking force the GVWR (Gross Vehicle Weight Rating) of the trailer.

### Electrical

Trailer lights, Electric Brakes, Break-away systems - Every time you tow, be sure to check that all components are working properly.

Wiring identification by color:

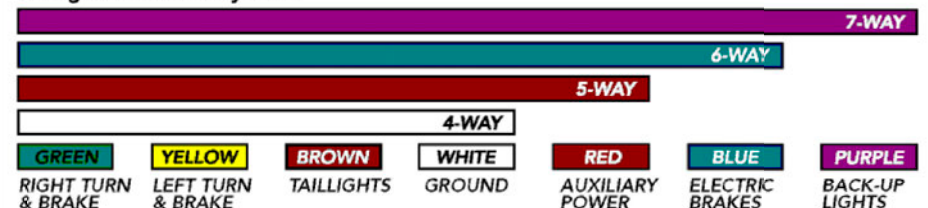

CURT DISCLAIMER: WIRING COLOR SHOWN WORK IN CONJUNCTION WITH CURT MANUFACTURING PRODUCTS.



15005

2019 RAM 1500

3/17/2021

GROSS LOAD CAPACITY WHEN USED AS A WEIGHT CARRYING HITCH: 15,000 LBS. TRAILER WEIGHT & 1,700 LBS. TONGUE WEIGHT.  
 GROSS LOAD CAPACITY WHEN USED AS A WEIGHT DISTRIBUTION HITCH: 17,000 LBS. TRAILER WEIGHT & 1,700 LBS. TONGUE WEIGHT



**WARNING: \*\*\* DO NOT EXCEED VEHICLE MANUFACTURER'S RECOMMENDED TOWING CAPACITY. \*\*\***



Parts List			
ITEM	QTY	PART NUMBER	DESCRIPTION
1	1	15005-DSBP	DRIVER SIDE BUMPER PLATE
2	1	15005-PSBP	PASSENGER SIDE BUMPER PLATE
3	6	10-10272	BOLT,CAR,1/2-13 UNC,1-3/4,GRD8,YZ
4	2	10-10370	HHCS,1/2-13 UNC,1-3/4,GRD8,YZ
5	2	10-10498	HHCS,M10x1.5,35,CL10.9,YZ
6	8	20-00062	NUT, SER-FLANGE,1/2-13 UNC,GRD8,YZ
7	6	20-00164	NUT,FLANGE,M10x1.5,CL10,YZ
8	4	20-00190	NUT,FLANGE,M14x2,CL10,YZ
9	4	30-00131	WASHER,FLAT,5/8,YZ
10	2	30-00149	WASHER,S-CON,1/2,YZ
11	6	CM-SP1	.250 x 1.50 x 2.00" SQUARE HOLE SPACER
12	6	1_2 FISHWIRE	1/2" FISHWIRE

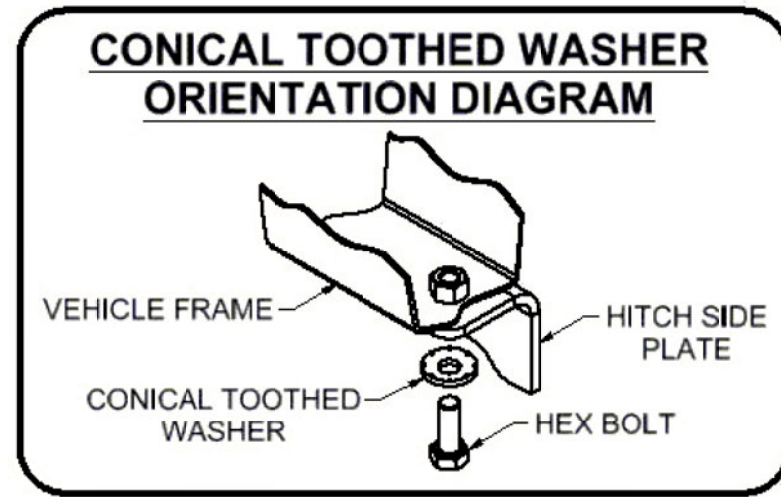

**FISHWIRE TECHNIQUE**  
 INSERT COILED END OF FISHWIRE TOOL THROUGH HITCH MOUNTING HOLE IN VEHICLE FRAME RAIL AND OUT THE ACCESS HOLE. PASS COILED END OF FISHWIRE THROUGH SPACER AND THREAD BOLT INTO COIL. KINK WIRE TO KEEP SPACER SEPARATE FROM BOLT AS SHOWN. PULL FISHWIRE, SPACER, AND BOLT THROUGH FRAME AND OUT MOUNTING HOLE. USE FISHWIRE TO GUIDE HITCH DURING MOUNTING AND PREVENT LOSS OF BOLT / SPACER INSIDE FRAME RAIL.

\*\*NOTE: SOME VEHICLES MAY FISHWIRE THROUGH END OF FRAME\*\*

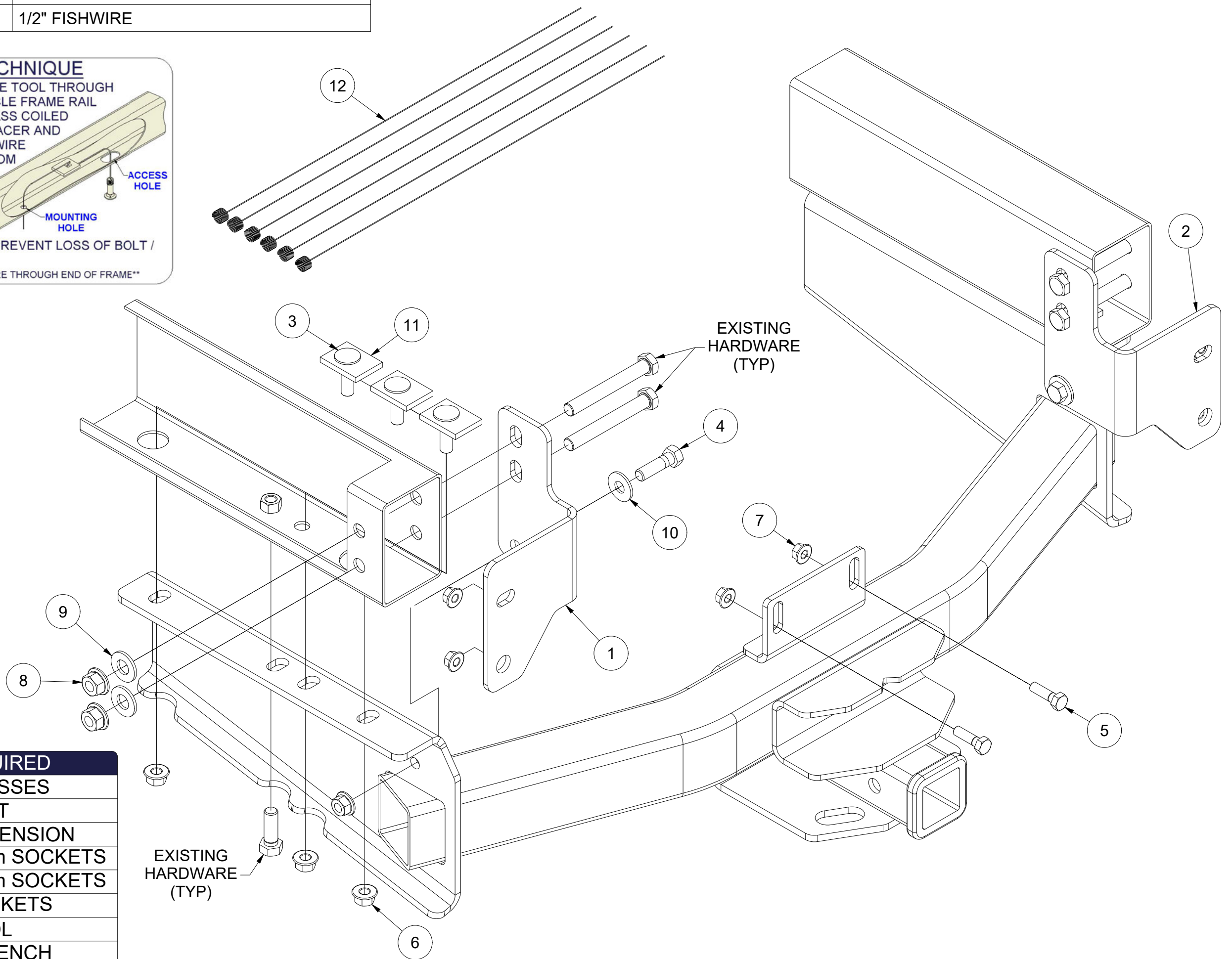

TOOLS REQUIRED
SAFETY GLASSES
RATCHET
6" SOCKET EXTENSION
10mm, 15mm, 16mm SOCKETS
17mm, 21mm, 22mm SOCKETS
3/4", 7/8" SOCKETS
PRY TOOL
TORQUE WRENCH
HAMMER

HITCH WEIGHT: 68 LBS.

INSTALL TIME

PROFESSIONAL: 60 MINUTES

NOVICE (DIY): 120 MINUTES

INSTALL NOTES:

- NO DRILLING REQUIRED
- FISHWIRING REQUIRED

**WELDNUT CLEANING**

To remove debris from weldnuts in frame, spray lubricant or compressed air into hole. For heavy debris, use a small wire brush. (Be careful not to damage threads).

**FRONT**  
**REAR**

**PERIODICALLY CHECK THIS RECEIVER HITCH TO ENSURE THAT ALL FASTENERS ARE TIGHT AND THAT ALL STRUCTURAL COMPONENTS ARE SOUND.**

CURT Manufacturing LLC., warrants this product to be free of defects in material and/or workmanship at the time of retail purchase by the original purchaser. If the product is found to be defective, CURT Manufacturing LLC., may repair or replace the product, at their option, when the product is returned, prepaid, with proof of purchase. Alteration to, misuse of, or improper installation of this product voids the warranty. CURT Manufacturing LLC.'s liability is limited to repair or replacement of products found to be defective, and specifically excludes liability for incidental or consequential loss or damage.

This product complies with safety specifications and requirements for connecting devices and towing systems of the state of New York, V.E.S.C.Regulation V-5 and SAE J684.

15005

2019 RAM 1500

3/17/2021

GROSS LOAD CAPACITY WHEN USED AS A WEIGHT CARRYING HITCH: 15,000 LBS. TRAILER WEIGHT & 1,700 LBS. TONGUE WEIGHT.  
GROSS LOAD CAPACITY WHEN USED AS A WEIGHT DISTRIBUTION HITCH: 17,000 LBS. TRAILER WEIGHT & 1,700 LBS. TONGUE WEIGHT



**WARNING: \*\*\* DO NOT EXCEED VEHICLE MANUFACTURER'S RECOMMENDED TOWING CAPACITY. \*\*\***



### INSTALLATION STEPS

1. Locate and remove the spare tire. Set aside for reinstallation later.
2. On the outside of the driver side frame, unplug the electrical connector. Remove the plastic wiring connectors from the factory hitch.
3. Remove the (2) factory M10 hex nuts located behind the license plate. While supporting the bumper, locate and remove the (4) factory M10 hex nuts from the bumper beam. Set bumper aside for reinstallation.
4. Locate and remove the (3) factory M14 bolts on the outside of the driver side frame rail and (1) M14 bolt from the underside of the frame. Repeat on the passenger side frame rail to remove the factory hitch. Save for reinstallation.
5. Remove (2) factory M6 bolts from the passenger side and (1) M6 bolt on the driver side from the exhaust heat shield. The heat shield tabs will be pinched between the frame and the hitch. Return M6 hardware to customer.
6. Fishwire the 1/2" carriage bolts and spacers in through the end of the frame rail to the three mounting holes on both frame rails.
7. Raise hitch into position. Secure hitch to the vehicle frame using 1/2" hex flange nuts. Reinstall short factory M14 bolt and finish securing the hitch to the frame.
8. Align the driver side bumper bracket with the (2) inside mounting holes on the frame. Secure the bracket to the frame using the long factory M14 bolts removed earlier and (2) M14 hex flange nuts. Repeat on the passenger side.
9. Secure the driver side bumper bracket to the hitch using (1) 1/2" hex bolt, (1) conical tooth washer and (1) 1/2" hex flange nut. Repeat on passenger side.
10. Reinstall the bumper, aligning the mounting studs with the mounting holes in the bumper brackets. Secure the bumper to the bumper brackets using (4) M10 hex flange nuts.
11. Reinstall the electrical connector and wiring connectors from step 2. Torque all 1/2" fasteners to 110 ft-lbs and M14 fasteners 126 ft-lbs.

**PERIODICALLY CHECK THIS RECEIVER HITCH TO ENSURE THAT ALL FASTENERS ARE TIGHT AND THAT ALL STRUCTURAL COMPONENTS ARE SOUND.**

CURT Manufacturing LLC., warrants this product to be free of defects in material and/or workmanship at the time of retail purchase by the original purchaser. If the product is found to be defective, CURT Manufacturing LLC., may repair or replace the product, at their option, when the product is returned, prepaid, with proof of purchase. Alteration to, misuse of, or improper installation of this product voids the warranty. CURT Manufacturing LLC.'s liability is limited to repair or replacement of products found to be defective, and specifically excludes liability for incidental or consequential loss or damage. This product complies with safety specifications and requirements for connecting devices and towing systems of the state of New York, V.E.S.C.Regulation V-5 and SAE J684.

Discover other trailer hitches and towing on our website.