

INSTALLATION MANUAL

13507

Level of Difficulty

Difficult

Installation difficulty levels are based on time and effort involved and may vary depending on the installer level of expertise, condition of the vehicle and proper tools and equipment.

Weight Carrying Capacity

Gross trailer weight (GTW)	7,500 lbs.
Tongue weight (TW)	750 lbs.

Weight Distribution Capacity

Weight distribution (WD)	7,500 lbs.
WD tongue weight (WDTW)	750 lbs.

Parts List

Item	Qty	Description
1	6	Hex bolt, 1/2"-13 x 1.5"
2	6	Conical-toothed washer, 1/2"
3	2	Carriage bolt, 5/16"-18 x 1.75"
4	2	Serrated-flange nut, 5/16"-18

Tools Required

Ratchet	Socket, 10mm
Torque wrench	Socket, 13mm
Flathead screwdriver	Socket, 21mm
Torx bit, T-30	Socket, 1/2"
Socket, 8mm	Socket, 3/4"

⚠ WARNING

Never exceed the vehicle manufacturer's recommended towing capacity.

Product Photo



NOTICE

Before you begin installation, read all instructions thoroughly.

This installation requires:

- Temporary removal of bumper cover

Proper tools will improve the quality of installation and reduce the time required.

Periodic inspection of the trailer hitch should be performed to ensure all mounting hardware remains tight and structural components are secure.

To help prevent damage to the product or vehicle, refer to the specified torque specifications when securing hardware during the installation process.

SAFETY INSTRUCTIONS

Safety glasses should be worn at all times while installing this product.

ASSEMBLY

Parts List

Item	Qty	Description
1	6	Hex bolt, 1/2"-13 x 1.5"
2	6	Conical-toothed washer, 1/2"
3	2	Carriage bolt, 5/16"-18 x 1.75"
4	2	Serrated-flange nut, 5/16"-18

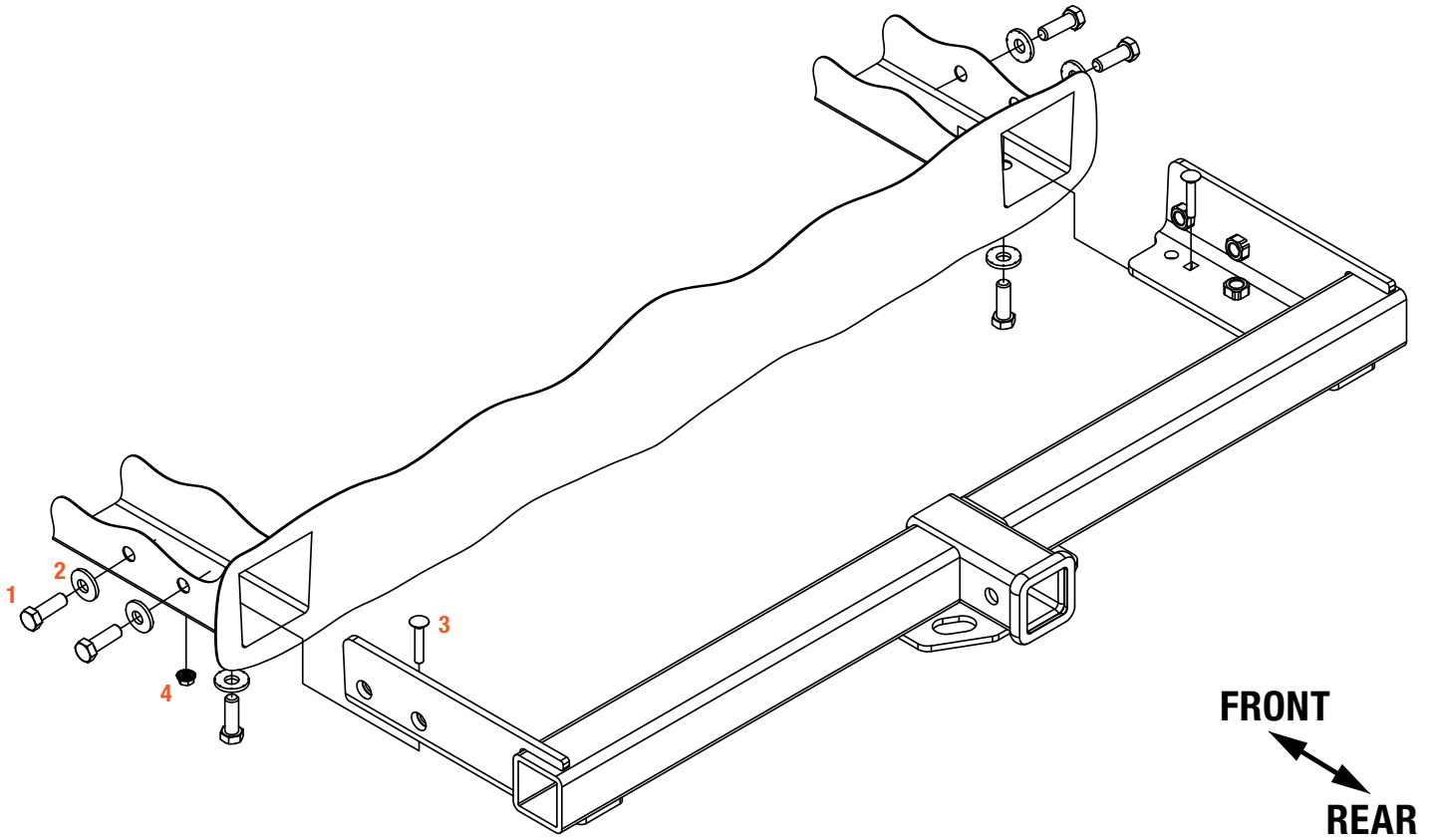

CONICAL TOOTHED WASHER ORIENTATION

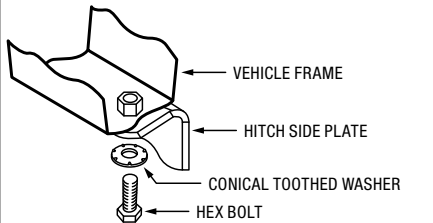

Step 1

Remove four bolts from the bottom of the bumper cover using a 10mm socket. Remove four bolts from each wheel well liner starting from the rear working up using an 8mm socket.

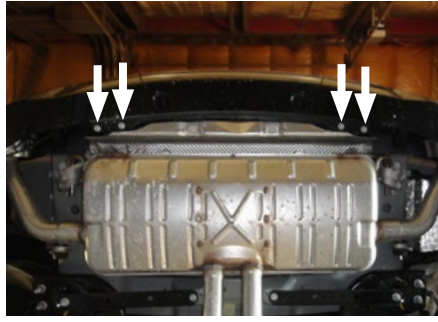

Step 2

Gently pull the wheel trim away from the vehicle, starting at the bottom and working up. Squeezing the clips behind the wheel liner may ease removal.

Remove the newly exposed bolt using a 10mm socket.

Repeat on the other side of the vehicle.



Step 3

Disconnect the electrical connector located to the rear of the tire behind the bumper cover on each side by pulling the tab on the vehicle side of the connector towards the front of the vehicle then pushing it down.



Step 4

With the rear lift gate open, use a flat head screwdriver to remove the two black plugs in the bumper cover and remove the bolts with a 10mm socket.



Step 5

Remove the taillight cover and remove the exposed bolt using a T-30 torx bit. Gently remove the taillight by pulling it straight rearward from the vehicle.

Set aside for reinstallation.



Step 6

Remove the bumper cover by gently pulling it away from the vehicle, starting at the wheel well and working towards the rear.

Set aside for reinstallation.



Step 7

Remove one bolt from each exhaust hanger on the bottom of the frame rail using 13mm socket.

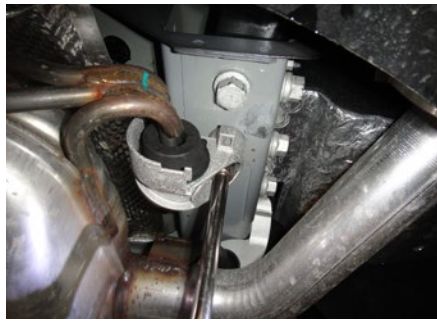

Step 8

Remove the rear bumper beam by removing two bolts from the outside and one bolt from the bottom of each frame rail using a 21mm socket. Return to the vehicle owner.



Step 9

Insert the hitch side plates into the end of the frame rails and loosely secure with supplied 1/2" bolts and conical toothed washers.

Insert 5/16" carriage bolts into the slots in the side plates by reaching in the end of the frame rail. Reinstall the exhaust using 5/16" serrated flange nuts.



Step 10

Torque 1/2" hardware to 110 ft-lbs.
Torque 5/16" hardware to 178 in-lbs.

Reinstall the bumper cover following steps 1 through 6 in reverse order.



Final Installed Image

