

INSTALLATION MANUAL

13499

Level of Difficulty

Difficult

Installation difficulty levels are based on time and effort involved and may vary depending on the installer level of expertise, condition of the vehicle and proper tools and equipment.

Weight Carrying Capacity

Gross trailer weight (GTW)	5,000 lbs.
Tongue weight (TW)	750 lbs.

Parts List

Item	Qty	Description
1	8	Hex bolt, M10
2	8	Conical-toothed washer, 7/16"

Tools Required

Ratchet	Torque wrench
Socket, 10mm	Torx bit, T-20
Socket, 16mm	Torx bit, T-25
Socket, 17mm	Trim panel pry tool
Socket extension, 6"	--

⚠ WARNING

Never exceed the vehicle manufacturer's recommended towing capacity.

Product Photo



NOTICE

Before you begin installation, read all instructions thoroughly.

Proper tools will improve the quality of installation and reduce the time required.

This installation requires:

- Temporarily removal of the bumper fascia and bumper beam

Periodic inspection of the trailer hitch should be performed to ensure all mounting hardware remains tight and structural components are secure.

To help prevent damage to the product or vehicle, refer to the specified torque specifications when securing hardware during the installation process.

SAFETY INSTRUCTIONS

Safety glasses should be worn at all times while installing this product.

ASSEMBLY

Parts List

Item	Qty	Description
1	8	Hex bolt, M10
2	8	Conical-toothed washer, 7/16"

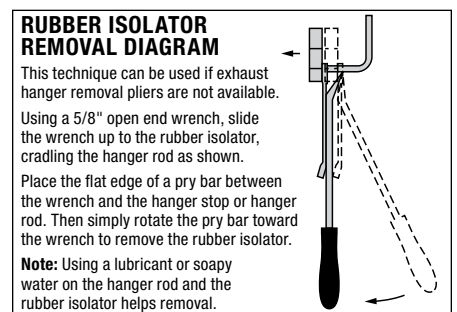
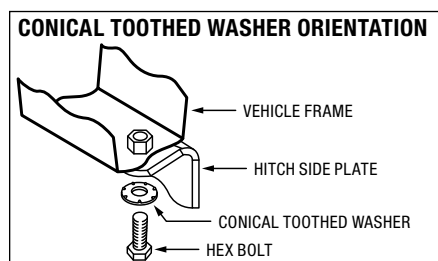
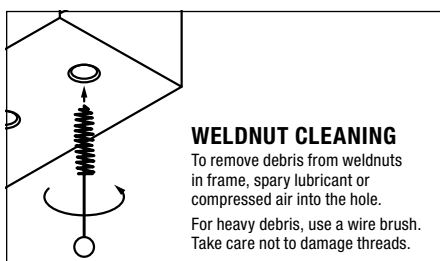
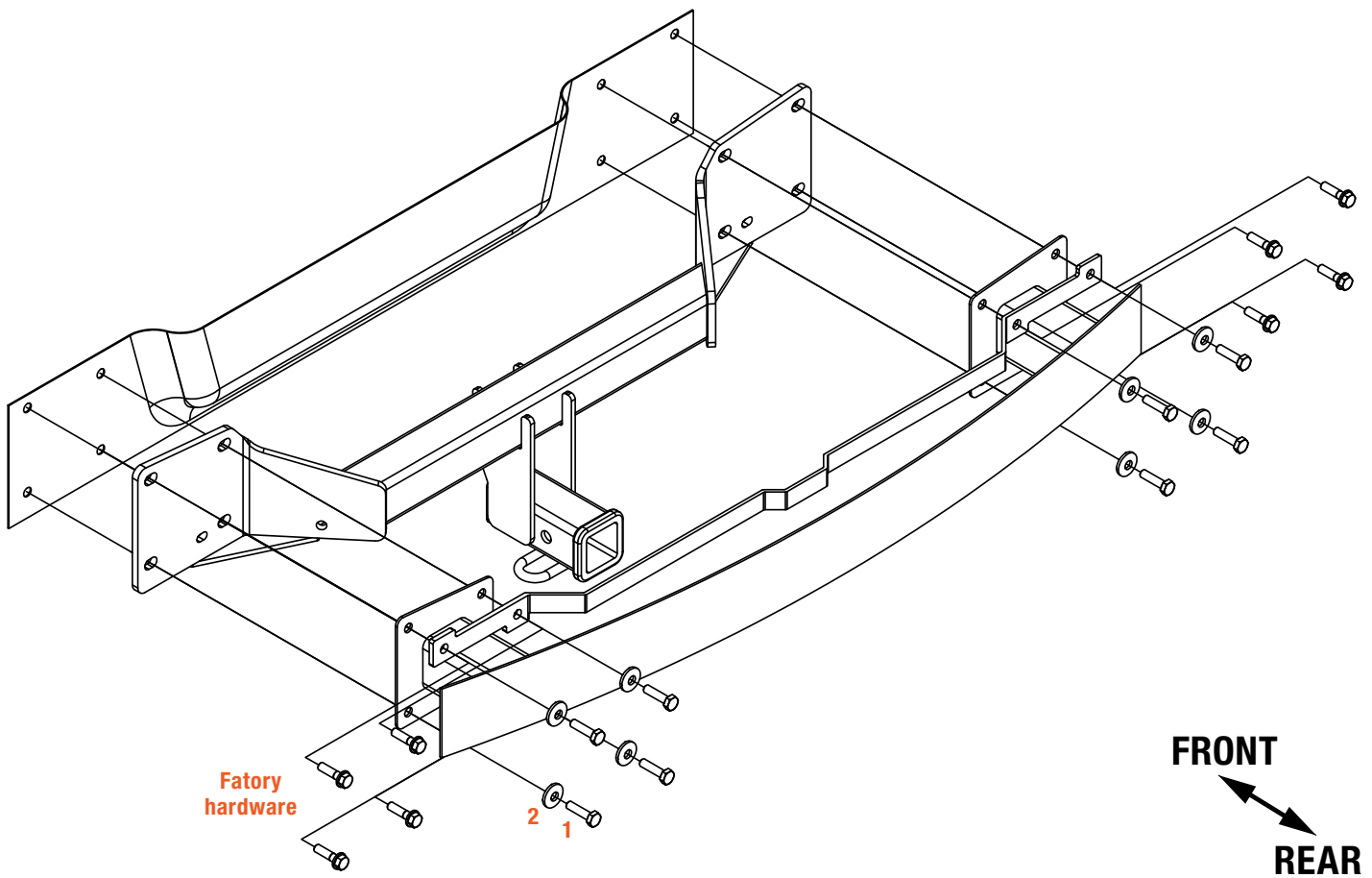

Step 1

Remove the four screws from the bottom of the bumper fascia and one screw from the bottom inside of each rear wheel well using a T-25 torx bit socket.

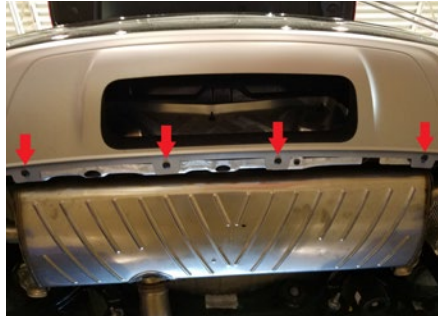

Step 2

Pull away the wheel well lining to reveal six screws, three on each side. Remove each screw using a T-25 torx bit socket.

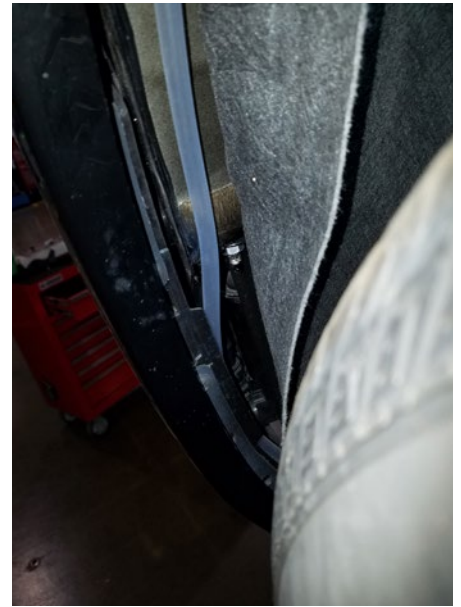

Step 3

Pull the wheel well trim away to reveal a screw and remove using a T-25 torx bit socket. Open the liftgate to reveal two screws and remove using a T-20 torx bit socket.



Step 4

Remove the trunk floor and use a trim panel pry tool to remove the trunk edge trim starting from the side.



Step 5

From the inside of the trunk, locate two rubber plugs, one on each side. Use the trim panel pry tool to remove the plugs to access the two nuts, one on each side. Remove each nut using a 10mm socket.



Step 6

Remove the access panel on both sides of the trunk and locate two nuts, one on each side. Remove the nuts using a 10mm socket.



Step 7

Gently remove the bumper fascia starting from the sides and working towards the rear of the vehicle. Set aside for later reinstallation.

Locate eight M10 bolts on the bumper beam and remove using a 16mm socket. Remove the bumper beam and bumper beam bracket and set aside for reinstallation in Step 8.

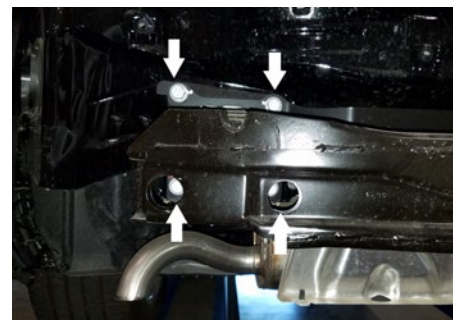

Step 8

Raise the hitch into position along with the bumper beam and bumper beam bracket and secure with the supplied M10 bolts (#1) and conical-toothed washers (#2).

Torque the M10 hardware to 45 ft-lbs.



Step 9

Reinstall the bumper fascia following steps 1 through 7 in reverse order.

Final Installed Image

