

INSTALLATION MANUAL

13471

Level of Difficulty

Easy

Installation difficulty levels are based on time and effort involved and may vary depending on the installer level of expertise, condition of the vehicle and proper tools and equipment.

Weight Carrying Capacity

Gross trailer weight (GTW)	3,500 lbs.
Tongue weight (TW)	525 lbs.

Parts List

Item	Qty	Description
1	4	Hex bolt, M12-1.25 x 40mm, CL10.9
2	4	Conical-toothed washer, 1/2"

Tools Required

Torque wrench	Flathead screwdriver
Socket, 19mm	--

⚠ WARNING

Never exceed the vehicle manufacturer's recommended towing capacity.

Product Photo



NOTICE

Before you begin installation, read all instructions thoroughly.

Proper tools will improve the quality of installation and reduce the time required.

This installation requires:

- Use of existing weldnuts

Periodic inspection of the trailer hitch should be performed to ensure all mounting hardware remains tight and structural components are secure.

To help prevent damage to the product or vehicle, refer to the specified torque specifications when securing hardware during the installation process.

SAFETY INSTRUCTIONS

Safety glasses should be worn at all times while installing this product.

ASSEMBLY

Parts List

Item	Qty	Description
1	4	Hex bolt, M12-1.25 x 40mm, CL10.9
2	4	Conical-toothed washer, 1/2"

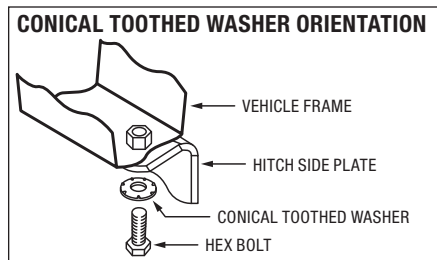
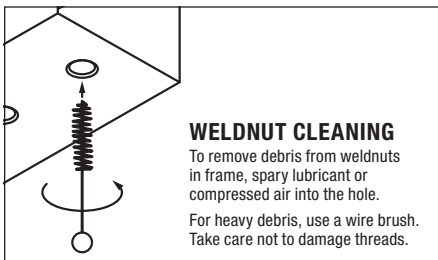
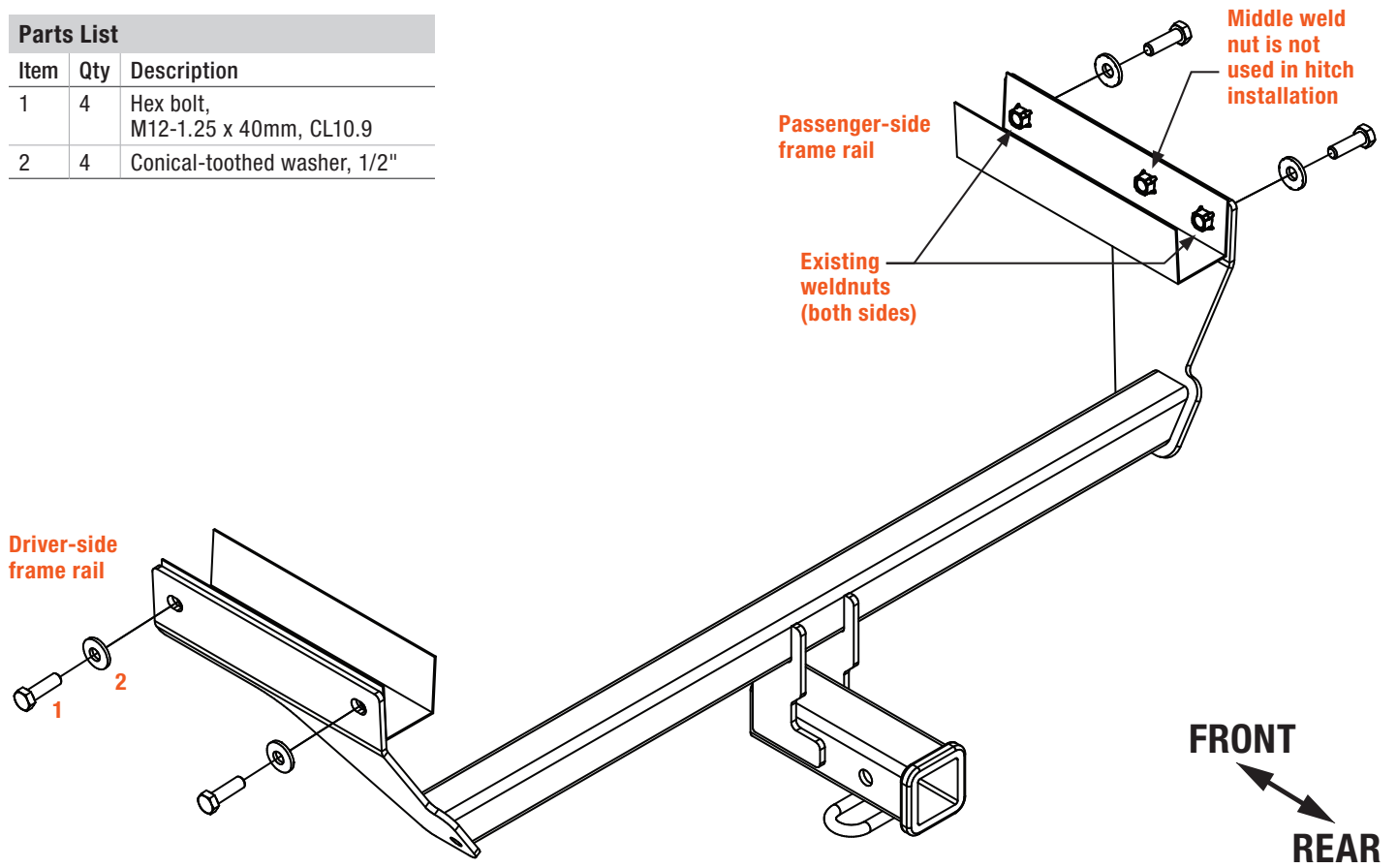

Step 1

Remove the two push fasteners located in the center of the rear bumper fascia for easier installation.

Set aside for reinstallation in Step 2.

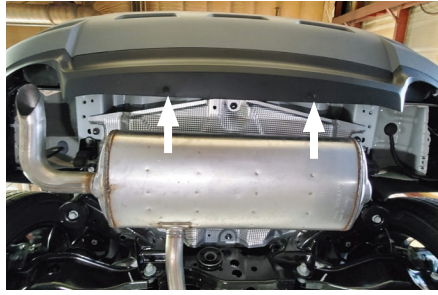

Step 2

Raise the trailer hitch into position by sliding the driver side of the hitch over the tailpipe first, then pulling the rear bumper fascia rearward for more clearance. Align the side plates with the rearmost and forward most holes in the vehicle's frame on both sides.

Loosely install the two provided hex bolts (#1) and conical-toothed washers (#2) into the existing weldnuts on both sides.

Torque all M12 fasteners to 86 lb-ft and reinstall the two push fasteners removed in Step 1.

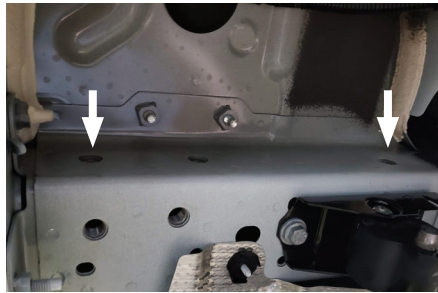

Final Installed Image

