

INSTALLATION MANUAL

13467

Level of Difficulty

Easy

Installation difficulty levels are based on time and effort involved and may vary depending on the installer level of expertise, condition of the vehicle and proper tools and equipment.

Weight Carrying Capacity

Gross trailer weight (GTW)	6,000 lbs.
Tongue weight (TW)	900 lbs.

Parts List

Item	Qty	Description
1	2	Hex bolt, M10-1.5 x 45mm, CL10.9
2	2	Conical-toothed washer, 7/16"

Tools Required

Ratchet	Utility knife
Socket, 15mm	Torque wrench
Socket extension, 6"	Tape measure
Torx bit, T-20	Paint marker
Tin snips	Pry tool

⚠ WARNING

Never exceed the vehicle manufacturer's recommended towing capacity.

Product Photo



NOTICE

Before you begin installation, read all instructions thoroughly.

Proper tools will improve the quality of installation and reduce the time required.

This installation requires:

- Use of existing hardware
- Part removal (rear bumper fascia and bumper beam)
- Trimming of the heat shield and rear bumper fascia
- Trimming of caulk around the bumper beam, if applicable

Periodic inspection of the trailer hitch should be performed to ensure all mounting hardware remains tight and structural components are secure.

To help prevent damage to the product or vehicle, refer to the specified torque specifications when securing hardware during the installation process.

SAFETY INSTRUCTIONS

Safety glasses should be worn at all times while installing this product.

ASSEMBLY

Parts List

Item	Qty	Description
1	2	Hex bolt, M10-1.5 x 45mm, CL10.9
2	2	Conical-toothed washer, 7/16"

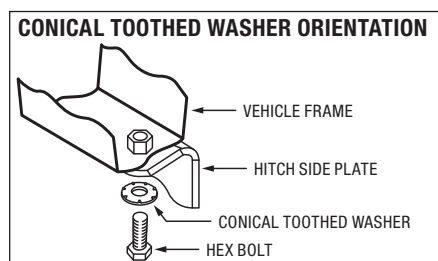
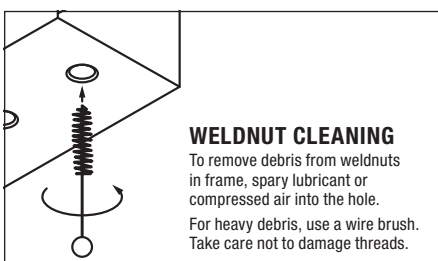
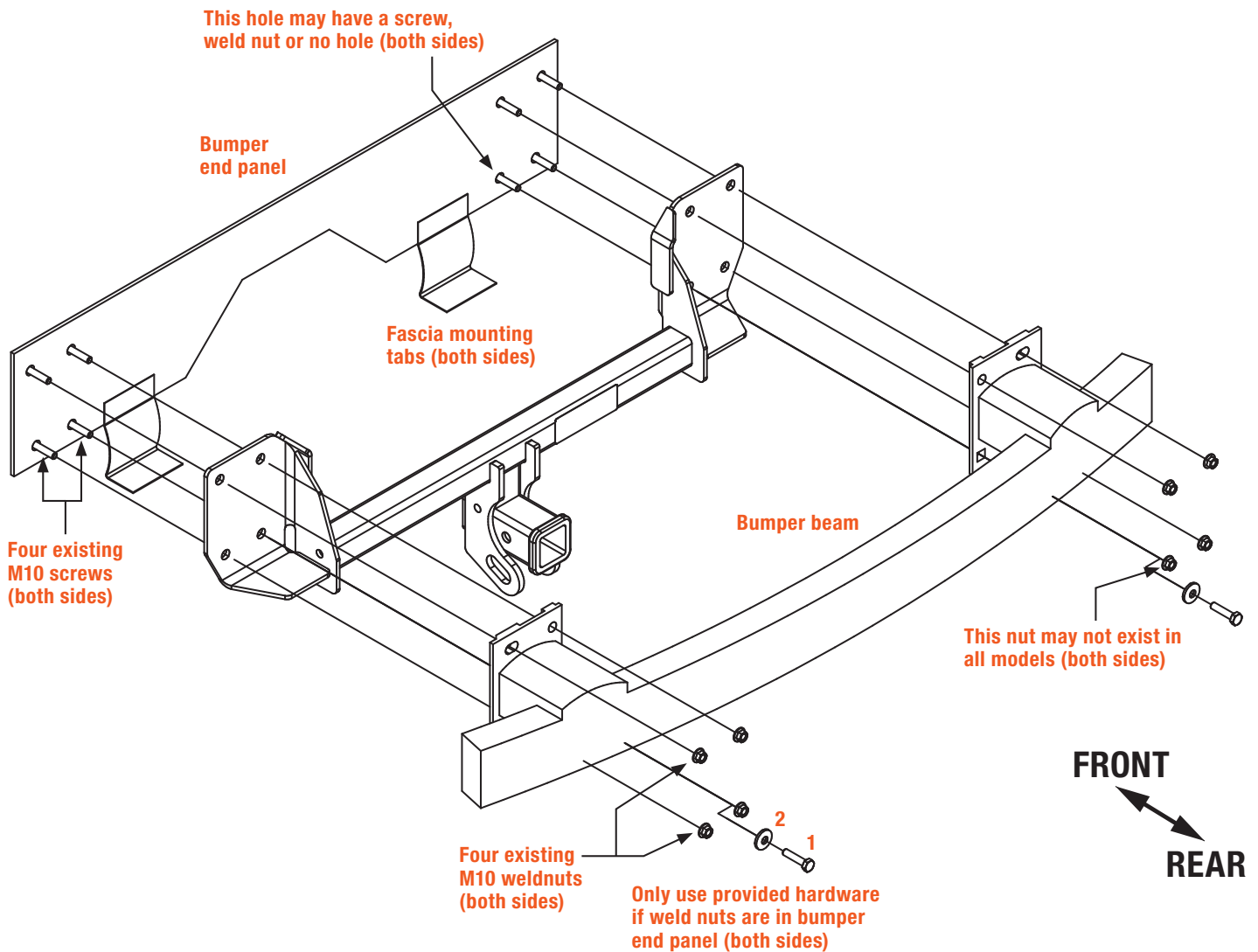

Step 1

Remove four screws from the bottom of the fascia.

On XC60 only: Remove seven screws from the wheel well on both sides of the vehicle.

On XC90 only: Remove five screws from the wheel well on both sides of the vehicle.

Set hardware aside for reinstallation in Step 8.



Step 2

Open the trunk and remove two bump stops, one on each side of the vehicle.

Set aside for reinstallation in Step 7.



Step 3

Gently pull enough of the wheel well trim out to remove the rear fascia on both sides of the vehicle. Gently remove the rear bumper fascia by pressing the three clips on the rear bumper fascia on each side, gently pulling the rear bumper fascia off the vehicle, and unplugging one or two connectors from fascia.

Set the fascia and connector(s) aside for reinstallation in Step 7.

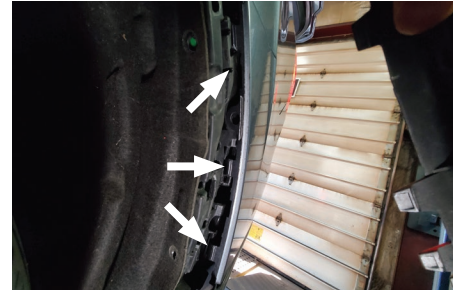

Step 4

Remove the bumper beam by unscrewing the three or four M10 flange nuts from the bumper beam on both sides of the vehicle. If applicable, trim the caulk around the bumper beam.

Set the bumper beam and fasteners aside for reinstallation in Step 6.

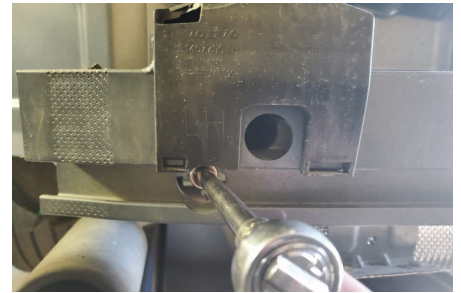
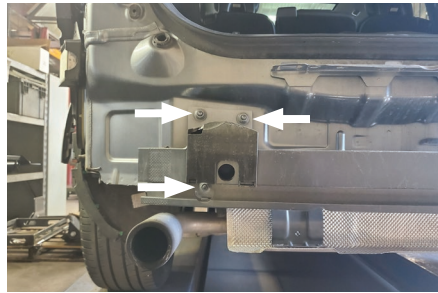

Step 5

Gently bend the two fascia mounting tabs rearward to allow clearance for the trailer hitch.

Trim the heat shield by cutting a centered rectangle 3" up from the bottom and 4" wide.

Trim both ends of the heat shield by cutting a rectangle 4" up from the bottom and 5" wide.

Gently bend the two fascia tabs forward to align with the holes in the heat shield.

On XC60 only: Slightly straighten the top most bend of the two fascia mounting tabs to allow clearance for the trailer hitch.

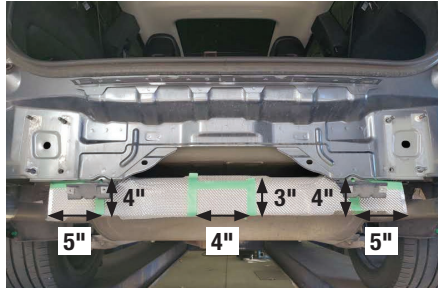
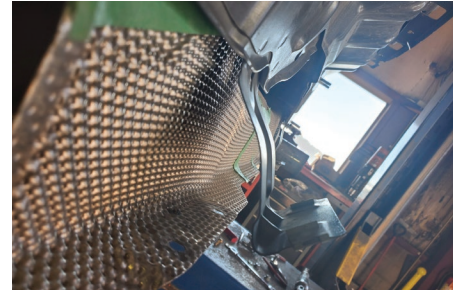

Step 6

Raise the trailer hitch into position over the existing M10 bolts on both sides of the vehicle. Place the bumper beam over the hitch.

Loosely install the three or four removed M10 flange nuts from Step 3 on both sides of the vehicle. If the bumper has three bolts and a weld nut that is accessible in the bumper end panel, screw in the provided M10 hex bolts (#1) and conical washers (#2). Torque all M10 hardware to 45 lb-ft.

Note: For easier nut installation, start with the lower nuts on the passenger side. Push on the bumper beam and screw the nut on just enough for thread engagement. Repeat on the lower nuts on the driver side. Loosely install the upper nuts on the passenger and driver side. Torque the upper nuts and then the lower nuts on the passenger side. Repeat on the driver side.



Step 7

Trim the fascia by cutting a centered rectangle 2-1/2" from the frontmost edge at the bottom of the fascia and 3-1/2" wide.

Reinstall the bumper stops, electrical connector(s) and fascia removed in Steps 2 and 3.

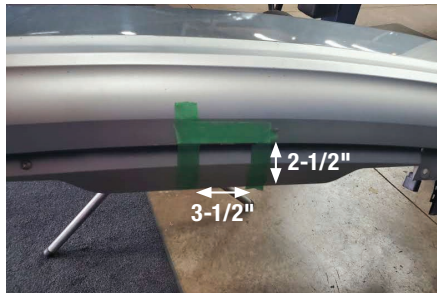

Step 8

Gently bend the fascia mounting tabs to line up with the holes in the fascia. Reinstall all fasteners removed in Step 1.

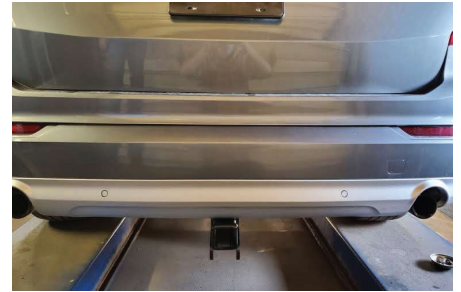
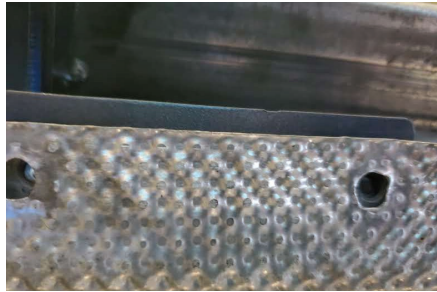

Final Installed Image

