

YEARS: 2014-2018

MAKE: SUBARU

MODEL: FORESTER

STYLE: ALL

WARNING: NEVER EXCEED YOUR VEHICLE MANUFACTURER'S RECOMMENDED TOWING CAPACITY

WEIGHT CARRYING:
 TRAILER WEIGHT: 3,500 LBS.
 TONGUE WEIGHT: 525 LBS.

PRO INSTALL TIME: 60 MIN.
NOVICE INSTALL TIME: 120 MIN.

IF YOU ARE HESITANT TO UNDERTAKE THIS TASK ON YOUR OWN, CONTACT AN AUTHORIZED CURT INSTALLER FOR ADDITIONAL ASSISTANCE.



INSTALLATION REQUIRES:

 SAFETY GLASSES	 RATCHET	 10mm 11/16" SOCKET
 6" SOCKET EXTENSION	 SCREW DRIVER	 TORQUE WRENCH
 PRY BAR	 ROTARY TOOL	 AVIATION SHEARS
 JACK STANDS		

INSTALLATION TIPS:

- BEFORE YOU BEGIN INSTALLATION, READ ALL INSTRUCTIONS THOROUGHLY.
- TO EASE INSTALLATION, 2 PEOPLE MAY BE REQUIRED.
- USING PROPER TOOLS WILL GREATLY IMPROVE THE QUALITY OF THE INSTALL AND REDUCE THE TIME REQUIRED.

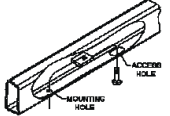
LEVEL OF DIFFICULTY: MODERATE

EASY	MODERATE	CHALLENGING
	FISHWIRE HARDWARE	
	RUBBER ISOLATOR REMOVAL	
	TRIM HEAT SHIELD AND FASCIA	

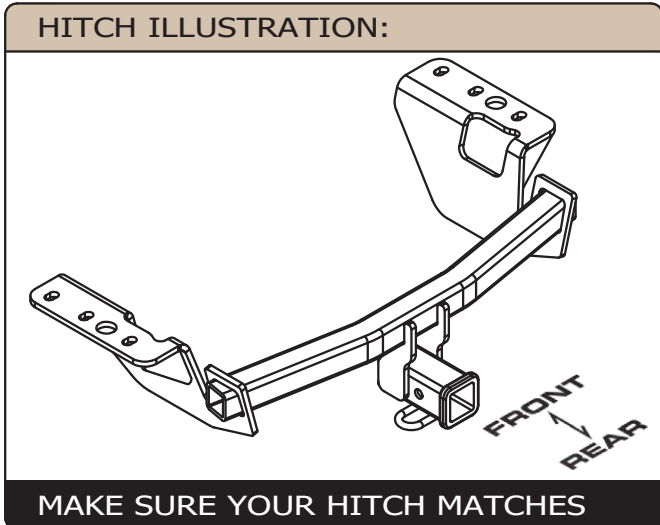

INSTALLATION WALKTHROUGH:

Parts List			
ITEM	QTY	PART NUMBER	DESCRIPTION
1	6	10-10314	BOLT, CAR,7/16-14 UNC,1-3/4,GRD8,YZ
2	6	20-00147	NUT,HEX,7/16-14 UNC,GRD8,YZ
3	6	30-00163	WASHER,S-CON,7/16,YZ
4	6	CM-SP2	.250 x .88 x 2.25" SQUARE HOLE SPACER
5	6	7_16 FISHWIRE	7/16" FISHWIRE

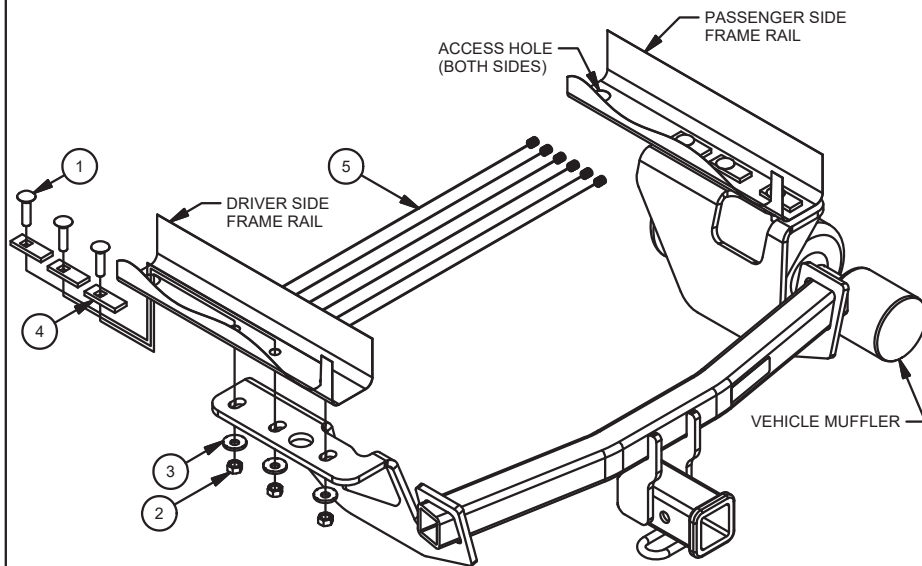

1. Remove (2) exhaust hangers from the passenger side muffler and (1) exhaust hanger from the center-front of vehicle for single exhaust vehicles, dual exhaust will remove (2) hangers from the driver side muffler as well. Support lowered exhaust with jack stand.

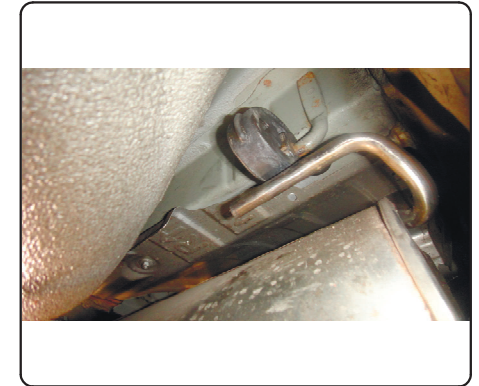

2. Remove (4) heat shield screws with phillips head screwdriver or 10mm socket (both sides if equipped with dual exhaust). Remove four hole plugs from each side of frame to expose mounting holes. Return all hole plugs to customer.

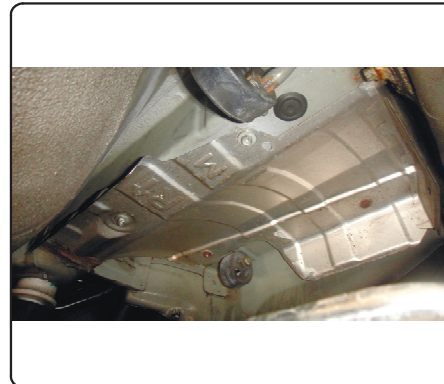

INSTALLATION WALKTHROUGH:

3. Fishwire 7/16" carriage bolts and spacers through the access holes in both sides of the frame into the three mounting holes. Trim and reinstall the heat shield using the (2) outer-most fasteners, the heat shield will be sandwiched between the sideplate and the frame.



4. Remove (2) push pins from the rear fascia, bend push pin mounting tabs away from the rear of the vehicle to allow space to raise hitch into place. Mark and trim the rear fascia, using the trim diagram as a reference.

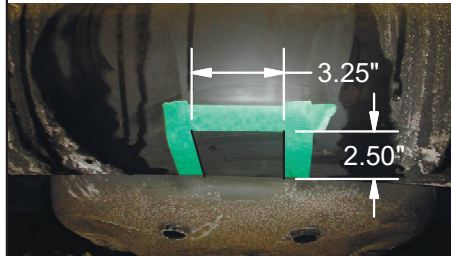
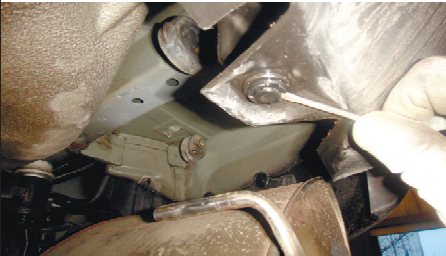

5. Raise hitch into place and secure hitch to frame using the 7/16" hardware provided. Torque all hardware to 70 lb-ft. Raise exhaust back into place and reattach exhaust hangers.

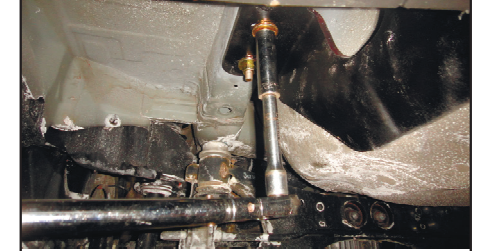

TOWING SAFETY INFORMATION

Gross Trailer Weight / GTW

The Gross Trailer Weight is the weight of the trailer & cargo. Measure this by putting the fully loaded trailer on a vehicle scale.

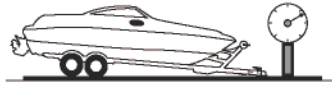

Tongue Weight / TW

The downward force that is exerted on the hitch ball by the coupler. The tongue weight will vary depending on where the load is positioned in relationship to the trailer axle(s). To measure the tongue weight, use either a commercial scale or a bathroom scale with the coupler at towing height. When using a bathroom scale with heavier tongue weights, use the method shown and multiply the scale reading by 3.

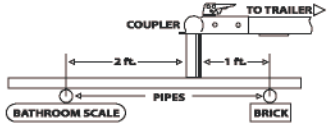

Weight Carrying / WC

The total weight of both the trailer and the cargo inside. Never exceed the weight capacity of your trailer hitch.

Weight Distribution / WD

Used to balance the weight of the cargo between the front and rear wheels throughout the trailer, allowing for better steering, braking, and level riding.



Sway Control

A device used to reduce the lateral movements of the trailer that are caused by the wind. This works in conjunction with a weight distribution hitch. Do not use this on a class 1 or 2 hitch, or with surge brakes.

How Much Can You Safely Tow?

TONGUE WEIGHT lbs	1000	2000	3000	4000	5000	6000	7000	8000	10,000	12,000
Tongue weight should be about 10 to 15 percent of the gross trailer weight.										
CLASS 1										
CLASS 2										
CLASS 3										
CLASS 4										
CLASS 5										
Camper	11'	12'	13'	14'	15'	16'				
lbs	1100	1200	1300	1400	1500	1600				
Vacation	14'	16'	18'	20'	22'	24'	26'	28'	30'	32'
lbs	2100	2400	2700	3000	3300	3600	3900	4200	4500	4800
Vacation	14'	16'	18'	20'	22'	24'	26'	28'	30'	32'
lbs	2800	3200	3600	4000	4400	4800	5200	5600	6000	6400
5th Wheel										

Refer to owner's manual for towing capabilities and limitations.

Ball Mount

The ball mount is placed inside the opening of the receiver hitch which is mounted to the vehicle. Make sure a hitch pin and clip is properly securing the ball mount to the receiver hitch before you begin towing.

- A: Rise. B: Drop. C: Hole Size. D: Length.

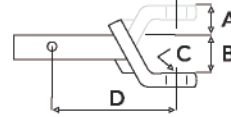

Trailer Ball

The connection from the hitch to the trailer. There are many factors that determine the correct hitch ball:

- Number one is the hitch ball's gross trailer weight rating.
- The mounting platform must be at least 3/8" thick.
- The hole diameter must not be more than 1/16" larger than the threaded shank.
- Every time you tow, check the nut and lock washer to make sure they are fastened securely.
- A: Ball Dia. B: Shank Dia. C: Shank Length. D: Shank Rise.

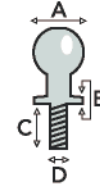

Coupler

The component that is placed over the trailer ball to connect the vehicle to the trailer. Be sure that the coupler size matches the size of the hitch ball and that the coupler handle is securely fastened. To determine what size hitch ball you need for your application you will need to know the size of coupler that is on the trailer. Be sure your coupler is properly adjusted to the ball you are using.

NOTE: For added security the use of safety devices such as Coupler Safety Pins and Locks is strongly recommended.

Safety Chains

Safety chains are a requirement and should be crossed under the tongue of the trailer so that the tongue will not drop to the road if it becomes separated from the hitch. Always leave enough slack so you can turn. Never allow the safety chains to drag on the ground and never attach the chains to the bumper.

Trailer Classification: Safety Chain Breaking Force - Minimum

- Class 1: 2,000 lbs. (8.9 kN)
- Class 2: 3,500 lbs. (15.6 kN)
- Class 3: 5,000 lbs. (22.2 kN)

The strength rating of each length of safety chain or its equivalent and its attachments shall be equal to or exceed in minimum breaking force the GVWR (Gross Vehicle Weight Rating) of the trailer.

Electrical

Trailer lights, Electric Brakes, Break-away systems - Every time you tow, be sure to check that all components are working properly.

Wiring identification by color:

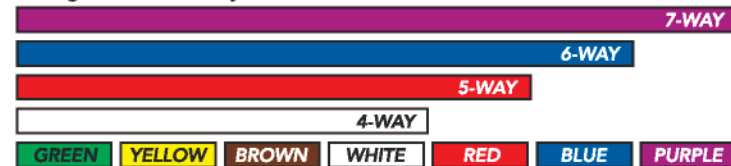

13435

SUBARU FORESTER

10/24/2019

GROSS LOAD CAPACITY WHEN USED AS A WEIGHT CARRYING HITCH: 3,500 LBS. TRAILER WEIGHT & 525 LBS. TONGUE WEIGHT.



WARNING: * DO NOT EXCEED VEHICLE MANUFACTURER'S RECOMMENDED TOWING CAPACITY *****



		Parts List	
ITEM	QTY	PART NUMBER	DESCRIPTION
1	6	10-10314	BOLT, CAR, 7/16-14 UNC, 1-3/4, GRD8, YZ
2	6	20-00147	NUT, HEX, 7/16-14 UNC, GRD8, YZ
3	6	30-00163	WASHER, S-CON, 7/16, YZ
4	6	CM-SP2	.250 x .88 x 2.25" SQUARE HOLE SPACER
5	6	7_16 FISHWIRE	7/16" FISHWIRE

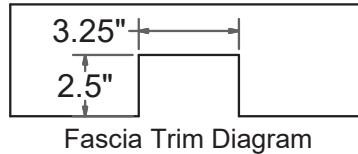
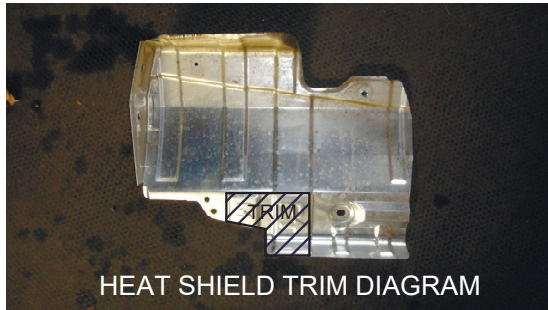
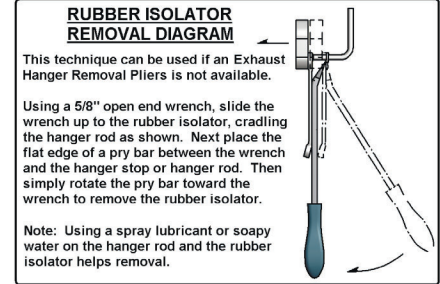
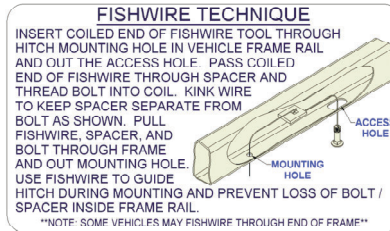

TOOLS REQUIRED

SAFETY GLASSES
RATCHET
10mm, 11/16" SOCKET
6" EXTENSION
SCREWDRIVER
TORQUE WRENCH
PRY BAR
ROTARY CUTTING TOOL
AVIATION SHEARS
JACK STANDS

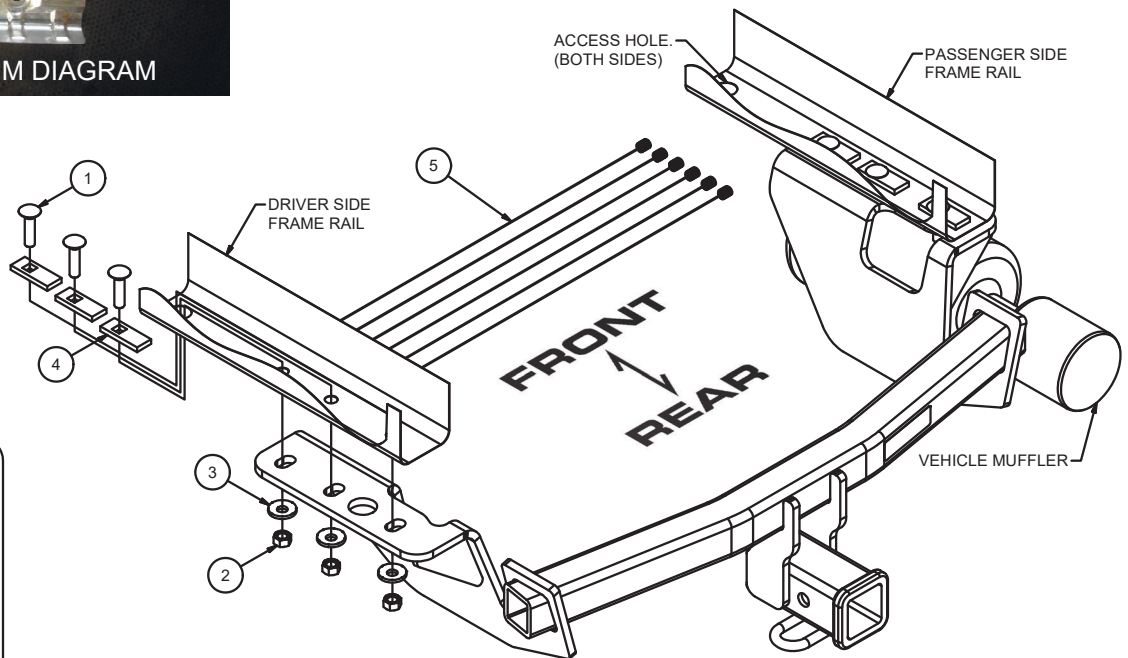

HITCH WEIGHT: 38 LBS.

INSTALL TIME

PROFESSIONAL: 60 MINUTES

NOVICE (DIY): 120 MINUTES

INSTALL NOTES:

- FISHWIRE HARDWARE
- LOWER EXHAUST
- HEAT SHIELD TRIMMING REQUIRED
- FASCIA TRIMMING REQUIRED

INSTALLATION STEPS

1. Remove (2) exhaust hangers from the passenger side muffler and (1) exhaust hanger from the center-front of vehicle for single exhaust vehicles, dual exhaust will remove (2) hangers from the driver side muffler as well. Support lowered exhaust with jack stand.
2. Remove (4) heat shield screws with phillips head screwdriver or 10mm socket (both sides if equipped with dual exhaust). Remove four hole plugs from each side of frame to expose mounting holes. Return all hole plugs to customer. Trim the heat shield and save for later installation.
3. Fishwire 7/16" carriage bolts and spacers through the access holes in both sides of the frame into the three mounting holes. Reinstall the heat shield using the (2) outer-most fasteners, the heat shield will be sandwiched between the sideplate and the frame.
4. Remove (2) push pins from the rear fascia, bend push pin mounting tabs away from the rear of the vehicle to allow space to raise hitch into place. Mark and trim the rear fascia, using the trim diagram as a reference.
5. Raise hitch into place and secure hitch to frame using the 7/16" hardware provided. Torque all hardware to 70 lb-ft. Raise exhaust back into place and reattach exhaust hangers.

PERIODICALLY CHECK THIS RECEIVER HITCH TO ENSURE THAT ALL FASTENERS ARE TIGHT AND THAT ALL STRUCTURAL COMPONENTS ARE SOUND.

Discover other trailer hitches and towing on our website.