



Safety glasses should be worn at all times while installing this product.

YEARS: 2017-PRESENT

MAKE: HONDA

MODEL: CR-V

STYLE: SUV

WARNING: NEVER EXCEED YOUR VEHICLE MANUFACTURER'S RECOMMENDED TOWING CAPACITY

WEIGHT CARRYING:
 TRAILER WEIGHT: 3,500 LBS.
 TONGUE WEIGHT: 525 LBS.

PRO INSTALL TIME: 30 MIN.
NOVICE INSTALL TIME: 60 MIN.

IF YOU ARE HESITANT TO UNDERTAKE THIS TASK ON YOUR OWN, CONTACT AN AUTHORIZED CURT INSTALLER FOR ADDITIONAL ASSISTANCE.

INSTALLATION REQUIRES:

RATCHET	11/16" 3/4" SOCKET	6" SOCKET EXTENSION
TORQUE WRENCH	MASKING TAPE	AVIATION SHEARS
SCREW DRIVER	PRY BAR	ELECTRICAL TAPE
SAFETY GLASSES		

INSTALLATION TIPS:

- BEFORE YOU BEGIN INSTALLATION, READ ALL INSTRUCTIONS THOROUGHLY.
- TO EASE INSTALLATION, 2 PEOPLE MAY BE REQUIRED.
- USING PROPER TOOLS WILL GREATLY IMPROVE THE QUALITY OF THE INSTALL AND REDUCE THE TIME REQUIRED.

LEVEL OF DIFFICULTY: EASY

EASY	MODERATE	CHALLENGING
	LOWER EXHAUST	
	FISHWIRE HARDWARE REQUIRED	
	FASCIA & BRACKET TRIM REQUIRED	

VEHICLE PHOTO:



REPRESENTATIVE PHOTO

HITCH ILLUSTRATION:

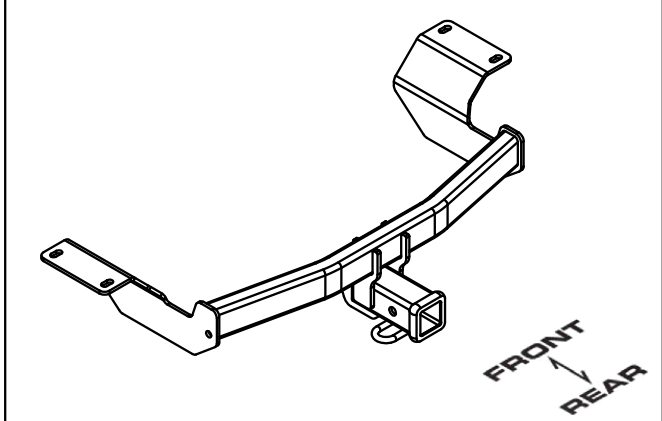

MAKE SURE YOUR HITCH MATCHES

PERIODICALLY CHECK THIS RECEIVER HITCH TO ENSURE ALL FASTENERS ARE TIGHT AND ALL STRUCTURAL COMPONENTS ARE SOUND
 CURT Manufacturing LLC. warrants this product to be free of defects in material and/or workmanship at the time of retail purchase by the original purchaser. If the product is found to be defective, CURT Manufacturing LLC. may repair or replace the product at their option, when the product is returned, prepaid, with proof of purchase. Alteration to, misuse of, or improper installation of this product voids the warranty. CURT Manufacturing LLC.'s liability is limited to repair or replacement of products found to be defective, and specifically excludes liability for incidental or consequential loss or damage.

INSTALLATION WALKTHROUGH:

Parts List			
ITEM	QTY	PART NUMBER	DESCRIPTION
1	4	7/16-14 x 1 1/4	CARRIAGE BOLT
2	4	CM-SP2	.250 x .88 x 2.25" SQUARE HOLE SPACER
3	4	7/16-14	HEX FLANGE NUT
4	4	7/16"	FISHWIRE
5	1	1/2 - 13 x 2"	CARRIAGE BOLT
6	1	CM-SP16	.250 x 1.50 x 2.00" ROUND HOLE SPACER
7	1	1/2 - 13"	HEX FLANGE NUT

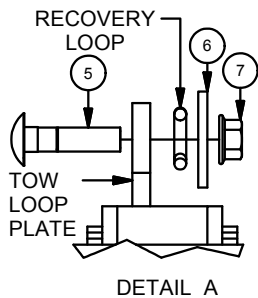
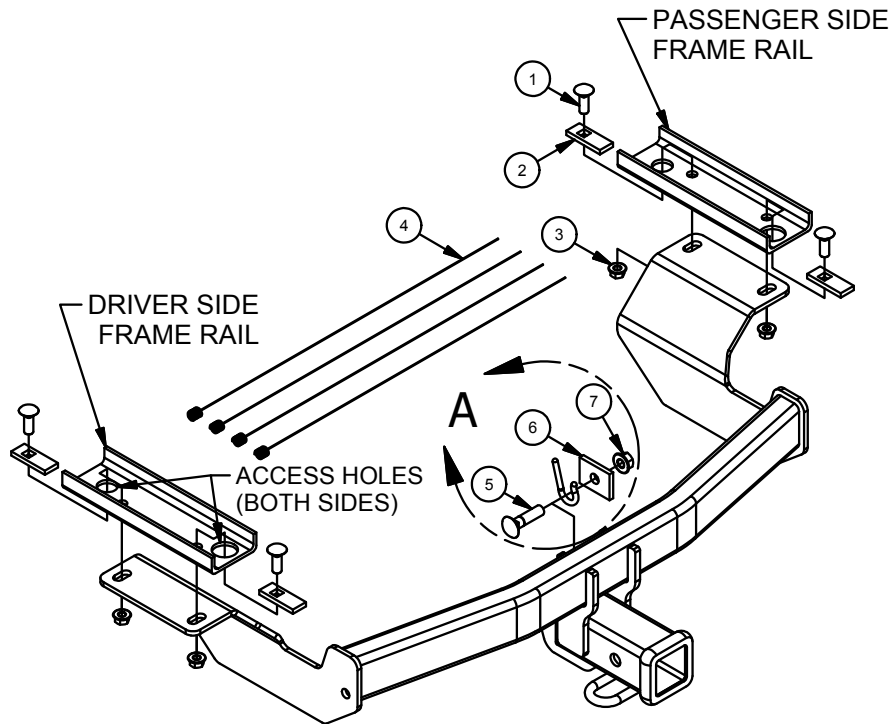

FRONT
↓
REAR

1. Lower exhaust by removing (3) rubber isolators from the exhaust towards the rear of the vehicle. Remove (5) fasteners from lower fascia.

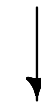
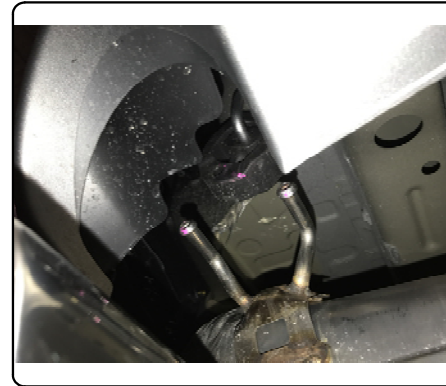

2. Fishwire (2) 7/16" carriage bolts and (2) CM-SP2 spacers through the vehicle access holes to the attachment holes on each side. See FISHWIRE DIAGRAM below.

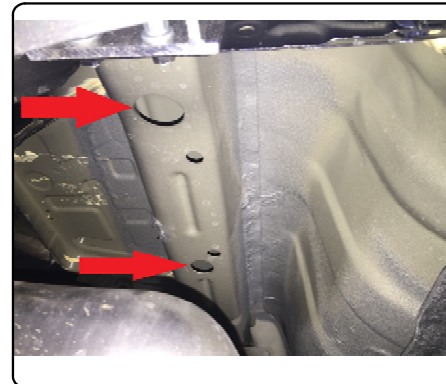

FISHWIRE TECHNIQUE
 INSERT COILED END OF FISHWIRE TOOL THROUGH HITCH MOUNTING HOLE IN VEHICLE FRAME RAIL AND OUT THE ACCESS HOLE. PASS COILED END OF FISHWIRE THROUGH SPACER AND THREAD BOLT INTO COIL. KINK WIRE TO KEEP SPACER SEPARATE FROM BOLT AS SHOWN. PULL FISHWIRE, SPACER, AND BOLT THROUGH FRAME AND OUT MOUNTING HOLE. USE FISHWIRE TO GUIDE HITCH DURING MOUNTING AND PREVENT LOSS OF BOLT / SPACER INSIDE FRAME RAIL.
 NOTE: SOME VEHICLES MAY FISHWIRE THROUGH END OF FRAME

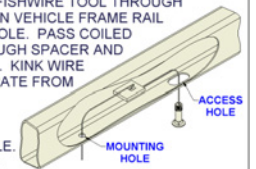

INSTALLATION WALKTHROUGH:

3. Trim lower fascia as shown in FASCIA TRIM DIAGRAM below.
CAUTION: Be aware of electrical components when trimming.
NOTE: Trimming of underbody panel may ease installation.

FASCIA TRIM DIAGRAM

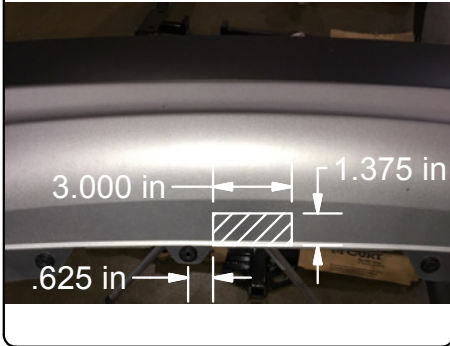

UNDERBODY PANEL

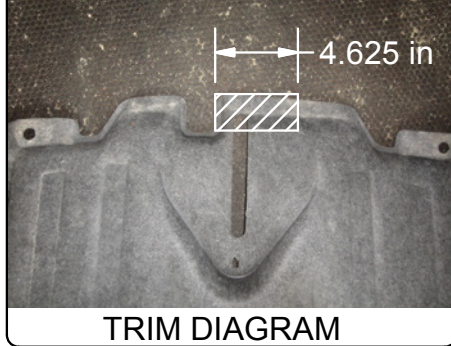

TRIM DIAGRAM

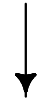

4. Raise hitch into position feeding the fishwires through the holes in the hitch. Once hitch is in place, remove the fishwires and loosely secure (2) 7/16" hex flange nuts on each side. Secure Tow Loop Plate to recovery loop using (1) 1/2" bolt, (1) CM-SP16 spacer and (1) 1/2" hex flange nut.

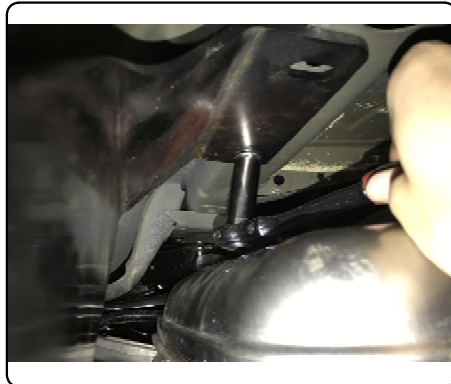

5. Torque all 7/16" hardware to 59 ft-lbs and all 1/2" hardware to 110 ft-lbs. Reinstall items removed in Steps 1.

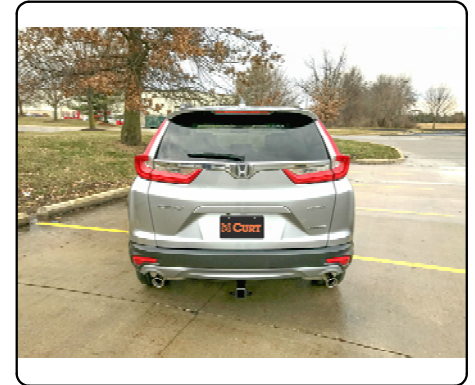
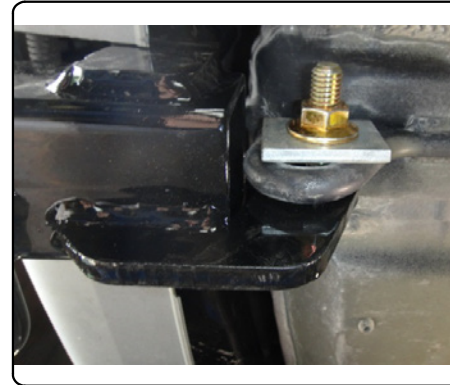

TOWING SAFETY INFORMATION

Gross Trailer Weight / GTW

The Gross Trailer Weight is the weight of the trailer & cargo. Measure this by putting the fully loaded trailer on a vehicle scale.

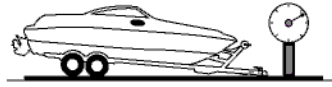

Tongue Weight / TW

The downward force that is exerted on the hitch ball by the coupler. The tongue weight will vary depending on where the load is positioned in relationship to the trailer axle(s). To measure the tongue weight, use either a commercial scale or a bathroom scale with the coupler at towing height. When using a bathroom scale with heavier tongue weights, use the method shown and multiply the scale reading by 3.

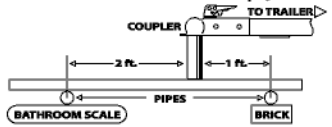

Weight Carrying / WC

The total weight of both the trailer and the cargo inside. Never exceed the weight capacity of your trailer hitch.

Weight Distribution / WD

Used to balance the weight of the cargo between the front and rear wheels throughout the trailer, allowing for better steering, braking, and level riding.



Sway Control

A device used to reduce the lateral movements of the trailer that are caused by the wind. This works in conjunction with a weight distribution hitch. Do not use this on a class 1 or 2 hitch, or with surge brakes.

How Much Can You Safely Tow?

TONGUE WEIGHT (lb)	1000	2000	3000	4000	5000	6000	7000	8000	10,000	12,000
Tongue weight should be about 10 to 15 percent of the gross trailer weight.										
CLASS 1										
CLASS 2										
CLASS 3										
CLASS 4										
CLASS 5										
TRAILER TYPE										
Camper	11'	12'	13'	14'	15'	16'				
lbs.	1100	1200	1300	1400	1500	1600				
Vacation	18'	19'	20'	22'	24'	26'	28'	30'	32'	
lbs.	2100	2400	2700	3000	3300	3600	3900	4200	4500	4800
Vacation	18'	19'	20'	22'	24'	26'	28'	30'	32'	
lbs.	2800	3200	3600	4000	4400	4800	5200	5600	6000	6400
5th Wheel										

Refer to owner's manual for towing capabilities and limitations.

Ball Mount

The ball mount is placed inside the opening of the receiver hitch which is mounted to the vehicle. Make sure a hitch pin and clip is properly securing the ball mount to the receiver hitch before you begin towing.

- A: Rise. B: Drop. C: Hole Size. D: Length.

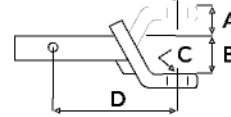

Trailer Ball

The connection from the hitch to the trailer. There are many factors that determine the correct hitch ball:

- Number one is the hitch ball's gross trailer weight rating.
- The mounting platform must be at least 3/8" thick.
- The hole diameter must not be more than 1/16" larger than the threaded shank.
- Every time you tow, check the nut and lock washer to make sure they are fastened securely.
- A: Ball Dia. B: Shank Length. C: Shank Dia. D: Shank Rise.



Coupler

The component that is placed over the trailer ball to connect the vehicle to the trailer. Be sure that the coupler size matches the size of the hitch ball and that the coupler handle is securely fastened. To determine what size hitch ball you need for your application you will need to know the size of coupler that is on the trailer. Be sure your coupler is properly adjusted to the ball you are using.

NOTE: For added security the use of safety devices such as Coupler Safety Pins and Locks is strongly recommended.

Safety Chains

Safety chains are a requirement and should be crossed under the tongue of the trailer so that the tongue will not drop to the road if it becomes separated from the hitch. Always leave enough slack so you can turn. Never allow the safety chains to drag on the ground and never attach the chains to the bumper.

Trailer Classification: Safety Chain Breaking Force - Minimum

Class 1: 2,000 lbs. (8.9 kN)

Class 2: 3,500 lbs. (15.6 kN)

Class 3: 5,000 lbs. (22.2 kN)

The strength rating of each length of safety chain or its equivalent and its attachments shall be equal to or exceed in minimum breaking force the GVWR (Gross Vehicle Weight Rating) of the trailer.

Electrical

Trailer lights, Electric Brakes, Break-away systems - Every time you tow, be sure to check that all components are working properly.

Wiring identification by color:

7-WAY						
6-WAY						
5-WAY						
4-WAY						
GREEN	YELLOW	BROWN	WHITE	RED	BLUE	PURPLE
RIGHT TURN & BRAKE	LEFT TURN & BRAKE	TAILLIGHTS	GROUND	AUXILIARY POWER	ELECTRIC BRAKES	BACK-UP LIGHTS

CURT DISCLAIMER: WIRING COLOR SHOWN WORK IN CONJUNCTION WITH CURT MANUFACTURING PRODUCTS.

13397

HONDA CR-V

GROSS LOAD CAPACITY WHEN USED AS A WEIGHT CARRYING HITCH: 3,500 LBS. TRAILER WEIGHT & 525 LBS. TONGUE WEIGHT.



WARNING: * DO NOT EXCEED VEHICLE MANUFACTURER'S RECOMMENDED TOWING CAPACITY *****



Parts List			
ITEM	QTY	PART NUMBER	DESCRIPTION
1	4	7/16-14 x 1 1/4	CARRIAGE BOLT
2	4	CM-SP2	.250 x .88 x 2.25" SQUARE HOLE SPACER
3	4	7/16-14	HEX FLANGE NUT
4	4	7/16"	FISHWIRE
5	1	1/2 - 13 x 2"	CARRIAGE BOLT
6	1	CM-SP16	.250 x 1.50 x 2.00" ROUND HOLE SPACER
7	1	1.2 - 13	HEX FLANGE NUT

FISHWIRE TECHNIQUE
 INSERT COILED END OF FISHWIRE TOOL THROUGH HITCH MOUNTING HOLE IN VEHICLE FRAME RAIL AND OUT THE ACCESS HOLE. PASS COILED END OF FISHWIRE THROUGH SPACER AND THREAD BOLT INTO COIL. KINK WIRE TO KEEP SPACER SEPARATE FROM BOLT AS SHOWN. PULL FISHWIRE, SPACER, AND BOLT THROUGH FRAME AND OUT MOUNTING HOLE. USE FISHWIRE TO GUIDE HITCH DURING MOUNTING AND PREVENT LOSS OF BOLT / SPACER INSIDE FRAME RAIL.
 NOTE: SOME VEHICLES MAY FISHWIRE THROUGH END OF FRAME

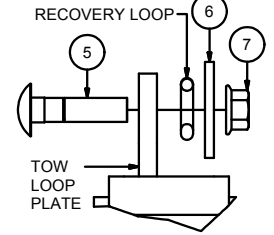
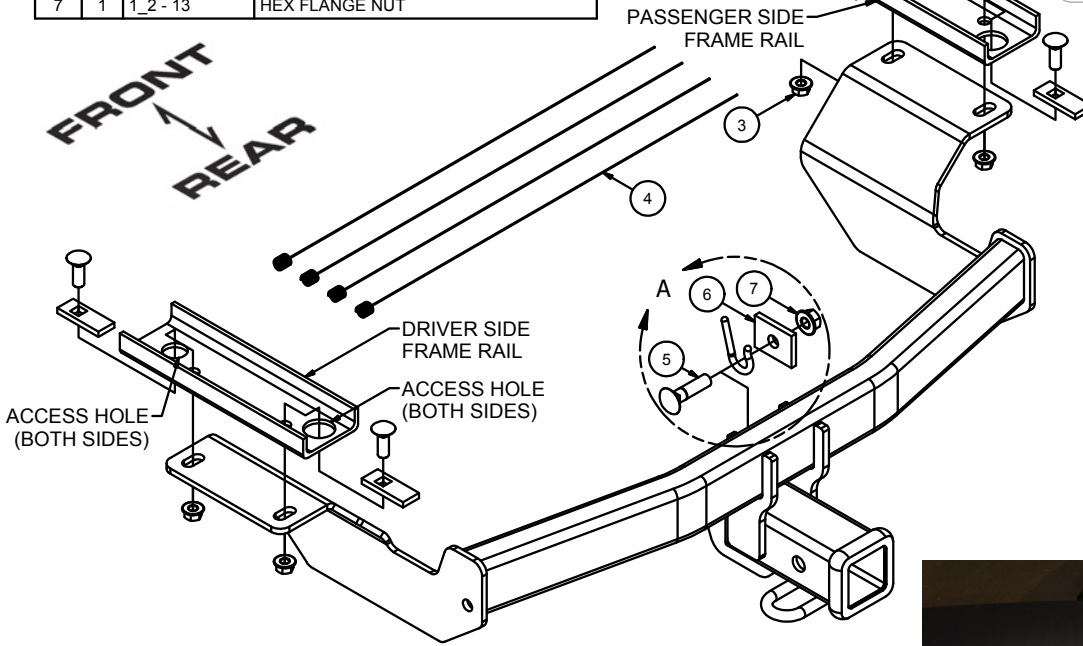

DETAIL A

TOOLS REQUIRED
RATCHET
1 1/16", 3/4" SOCKETS
6" SOCKET EXTENSION
TORQUE WRENCH
MASKING TAPE
AVIATION SHEARS
SCREW DRIVER
PRY BAR
ELECTRICAL TAPE
SAFETY GLASSES

RUBBER ISOLATOR REMOVAL DIAGRAM

This technique can be used if an Exhaust Hanger Removal Pliers is not available.

Using a 5/8" open end wrench, slide the wrench up to the rubber isolator, cradling the hanger rod as shown. Next place the flat edge of a pry bar between the wrench and the hanger stop or hanger rod. Then simply rotate the pry bar toward the wrench to remove the rubber isolator.

Note: Using a spray lubricant or soapy water on the hanger rod and the rubber isolator helps removal.

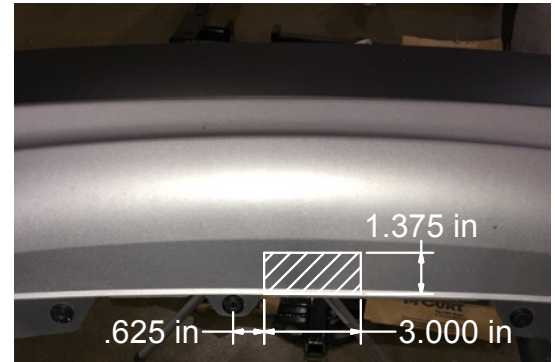

FASCIA TRIM DIAGRAM

HITCH WEIGHT: 30 LBS.

INSTALL TIME

PROFESSIONAL: 30 MINUTES
 NOVICE (DIY): 60 MINUTES

INSTALL NOTES:

- LOWER EXHAUST
- FISHWIRE HARDWARE REQUIRED
- FASCIA TRIM REQUIRED

INSTALLATION STEPS

1. Lower exhaust by removing (3) rubber isolators from the exhaust towards the rear of the vehicle. Remove (5) clips from lower fascia.
2. Fishwire (2) 7/16" carriage bolts and (2) CM-SP2 spacers through the vehicle access hole to the attachment holes on each side. (See fishwire diagram)
3. Trim lower fascia as shown in FASCIA TRIM DIAGRAM. **CAUTION:** Be aware of electrical components when trimming. NOTE: Trimming underbody panel may ease installation.
4. Raise hitch into position feeding the fishwires through the holes in the hitch. Once hitch is in place, remove the fishwires and loosely secure (2) 7/16" hex flange nuts on each side. Secure Tow Loop Plate to recovery loop using (1) 1/2" bolt, (1) CM-SP16 spacer, and (1) 1/2" hex flange nut.
5. Torque all 7/16" hardware to 59 ft-lbs and all 1/2" hardware to 110 ft-lbs. Reinstall items removed in Step 1.

PERIODICALLY CHECK THIS RECEIVER HITCH TO ENSURE THAT ALL FASTENERS ARE TIGHT AND THAT ALL STRUCTURAL COMPONENTS ARE SOUND.