

**13359**

97-03 FORD F-150 & F-250 LIGHT DUTY (NEW BODY STYLE)  
 99-CURRENT FORD F-250 & F-350 SUPER DUTY  
 2008-CURRENT FORD F-450 SUPER DUTY

4/8/2013

FITS 20" SPARE TIRE

GROSS LOAD CAPACITY WHEN USED AS A WEIGHT CARRYING HITCH: 6,000 LBS. TRAILER WEIGHT & 600 LBS. TONGUE WEIGHT.  
 GROSS LOAD CAPACITY WHEN USED AS A WEIGHT DISTRIBUTION HITCH: 10,000 LBS. TRAILER WEIGHT & 1,000 LBS. TONGUE WEIGHT

**\*\*\*DO NOT EXCEED VEHICLE MANUFACTURER'S RECOMMENDED TOWING CAPACITY.\*\*\***

Parts List			
ITEM	QTY	PART NUMBER	DESCRIPTION
1	6	1/2-13 x 1 3/4	CARRIAGE BOLT
2	6	CM-SP1	.250 x 1.50 x 2.00" SQUARE HOLE SPACER
3	6	HFN 1213	HEX FLANGE NUT

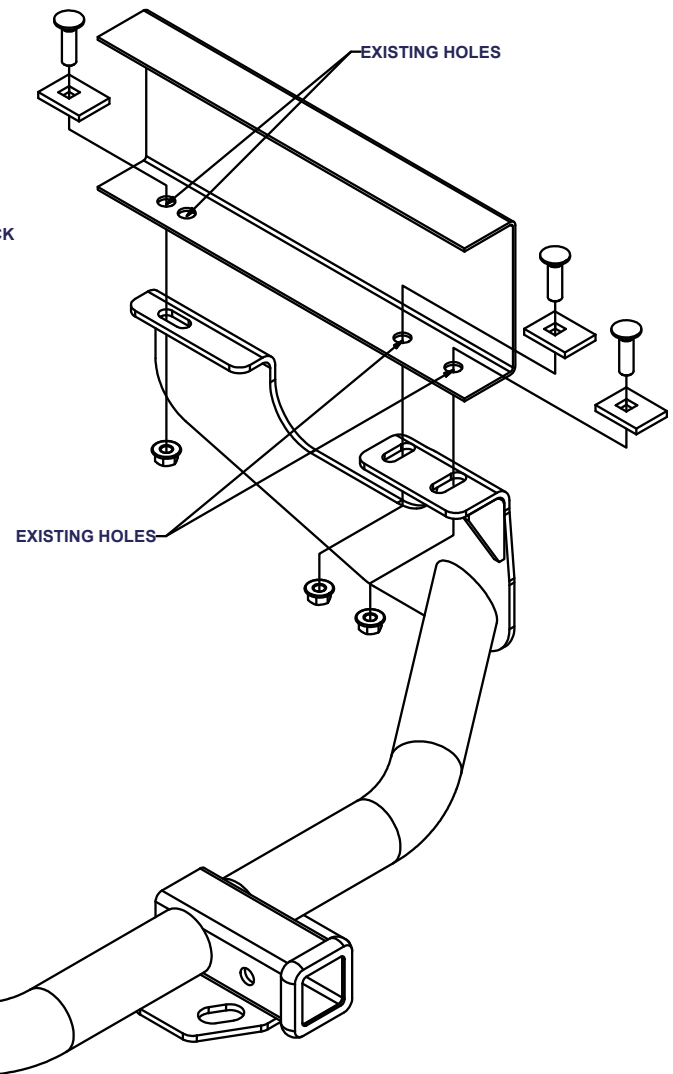
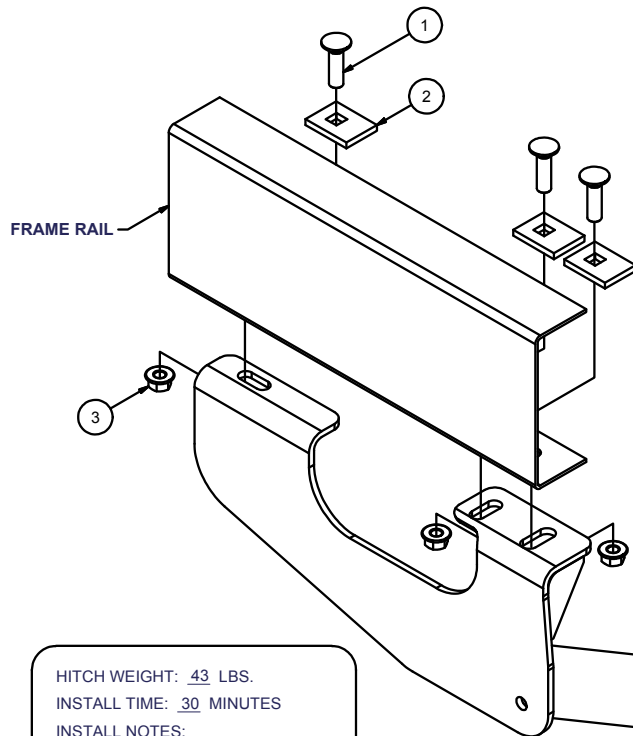
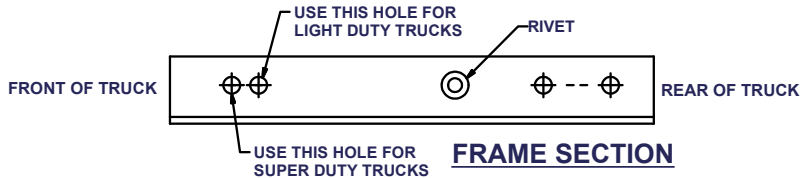

HITCH WEIGHT: 43 LBS.  
 INSTALL TIME: 30 MINUTES  
 INSTALL NOTES:  
 - NO DRILLING REQUIRED  
 - LOWER SPARE

## INSTALLATION STEPS

- 1) Lower the spare tire for ease of installation. (Spare tire will be replaced after the hitch is installed.)
- 2) Install 1/2" carriage bolts and spacers through existing holes in frame as shown.
- 3) Raise hitch into position over carriage bolts and secure with flange nuts as shown. Be sure the wiring harness near the end of the truck frame is not pinched between the hitch and frame.  
**(Note: Only one of the two holes toward the front of the truck will be used in the side plates.)**
- 4) Torque all 1/2" fasteners to 110 lb.-ft.
- 5) Raise the spare tire back into its storage location under truck.  
**(Note: Spare may need to be pushed toward front of truck to provide clearance between tire and hitch.)**

**PERIODICALLY CHECK THIS RECEIVER HITCH TO ENSURE THAT ALL FASTENERS ARE TIGHT AND THAT ALL STRUCTURAL COMPONENTS ARE SOUND.**

