

YEARS: 2017-PRESENT

MAKE: NISSAN

MODEL: PATHFINDER

STYLE: SUV

**WARNING: NEVER EXCEED YOUR VEHICLE MANUFACTURER'S RECOMMENDED TOWING CAPACITY**

**WEIGHT CARRYING:**  
 TRAILER WEIGHT: 6,000 LBS.  
 TONGUE WEIGHT: 900 LBS.

**WEIGHT DISTRIBUTION:**  
 TRAILER WEIGHT: 6,000 LBS.  
 TONGUE WEIGHT: 900 LBS.

**PRO INSTALL TIME: 40 MIN.**  
**NOVICE INSTALL TIME: 80 MIN.**

IF YOU ARE HESITANT TO UNDERTAKE THIS TASK ON YOUR OWN, CONTACT AN AUTHORIZED CURT INSTALLER FOR ADDITIONAL ASSISTANCE.

**INSTALLATION TIPS:**

- BEFORE YOU BEGIN INSTALLATION, READ ALL INSTRUCTIONS THOROUGHLY.
- TO EASE INSTALLATION, 2 PEOPLE MAY BE REQUIRED.
- USING PROPER TOOLS WILL GREATLY IMPROVE THE QUALITY OF THE INSTALL AND REDUCE THE TIME REQUIRED.



**INSTALLATION REQUIRES:**

<b>MARKER</b>	<b>MASKING TAPE</b>	<b>RATCHET</b>
<b>SAFETY GLASSES</b>	<b>12mm 18mm 19mm 21mm SOCKET</b>	<b>TAPE MEASURE</b>
<b>TORQUE WRENCH</b>	<b>ROTARY TOOL</b>	

**LEVEL OF DIFFICULTY: MODERATE**

EASY	MODERATE	CHALLENGING
	CLEAN OUT WELDNUTS	
	TEMPORARILY LOWER SPARE TIRE	
	MINOR FASCIA TRIMMING REQUIRED	
	REMOVE TOW HOOK	
	NO DRILLING REQUIRED	

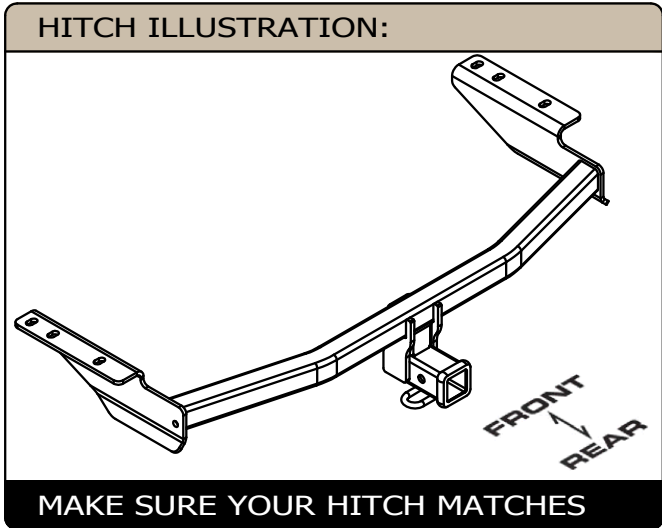

**PERIODICALLY CHECK THIS RECEIVER HITCH TO ENSURE ALL FASTENERS ARE TIGHT AND ALL STRUCTURAL COMPONENTS ARE SOUND**  
 CURT Manufacturing LLC. warrants this product to be free of defects in material and/or workmanship at the time of retail purchase by the original purchaser. If the product is found to be defective, CURT Manufacturing LLC. may repair or replace the product at their option, when the product is returned, prepaid, with proof of purchase. Alteration to, misuse of, or improper installation of this product voids the warranty. CURT Manufacturing LLC.'s liability is limited to repair or replacement of products found to be defective, and specifically excludes liability for incidental or consequential loss or damage.

## INSTALLATION WALKTHROUGH:

Parts List			
ITEM	QTY	PART NUMBER	DESCRIPTION
1	6	1/2"	CONICAL TOOTHED WASHER
2	6	M12-1.25 x 30mm	HEX BOLT

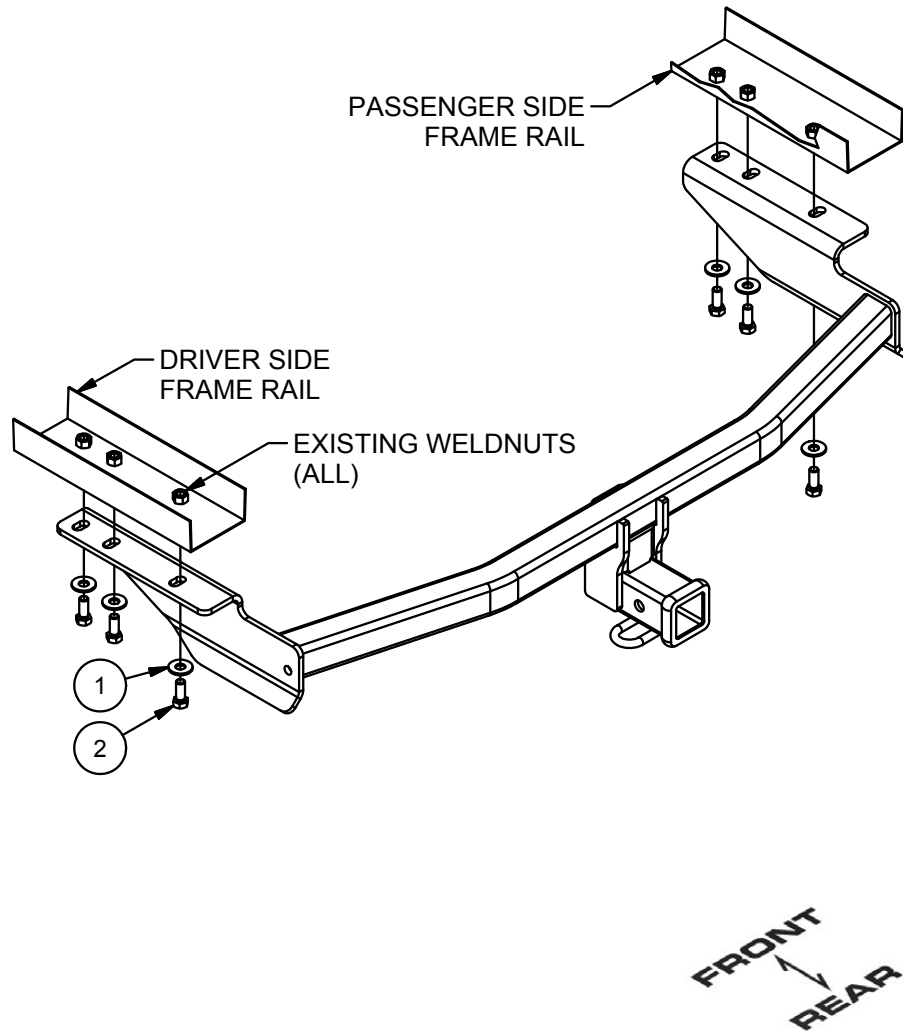

1. Remove tow hook from driver side frame rail using a 18mm socket to remove (4) bolts. Return tow hook and fasteners to vehicle owner.

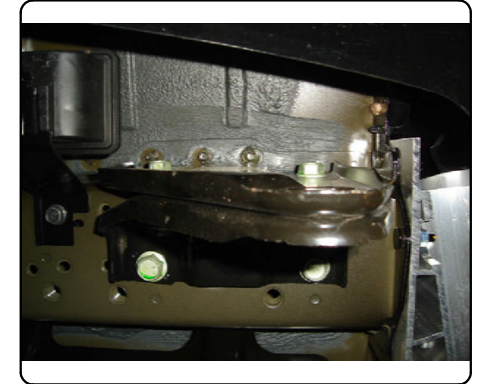

2. Lower spare tire using tire lug wrench or ratchet with 21mm socket.

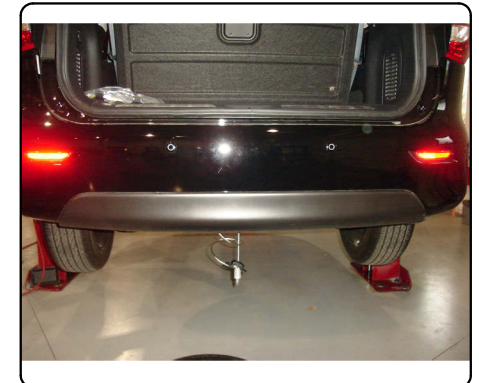

## INSTALLATION WALKTHROUGH:

3. Remove fascia mounting brackets by first removing plastic clips on bottom of fascia and then unbolting brackets from bumper using 12mm socket. Retain for reinstallation after hitch installation.



4. Locate center of vehicle fascia and mark area as shown for fascia trimming, approximately 3 1/4" x 1 3/8". Trim fascia.

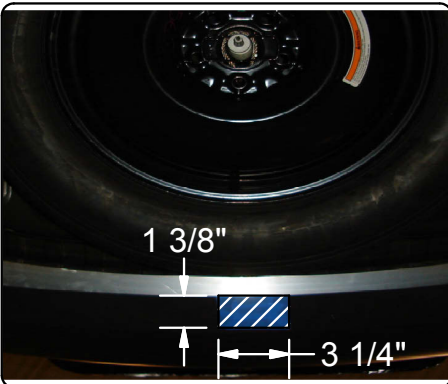

5. Raise hitch into position and secure with M12 x 1.25 x 30mm hex bolts and 1/2" conical toothed washers into existing weldnuts using 19mm socket. Torque all M12 fasteners to 86 ft-lbs.  
6. Reinstall fascia mounting brackets.

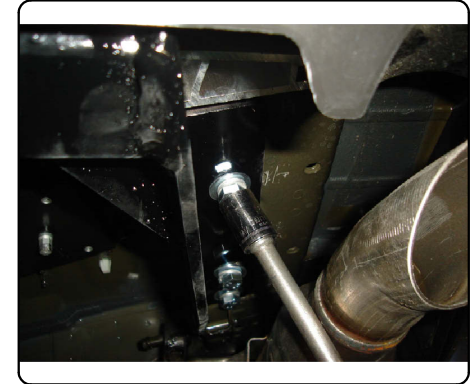
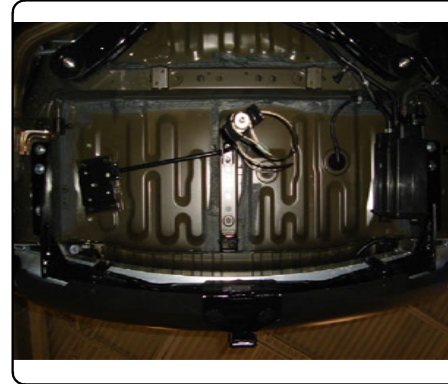

7. Raise spare tire back into position.



13309

## NISSAN PATHFINDER

GROSS LOAD CAPACITY WHEN USED AS A WEIGHT CARRYING HITCH: 6,000 LBS. TRAILER WEIGHT & 900 LBS. TONGUE WEIGHT.  
 GROSS LOAD CAPACITY WHEN USED AS A WEIGHT DISTRIBUTION HITCH: 6,000 LBS. TRAILER WEIGHT & 900 LBS. TONGUE WEIGHT



**WARNING: \*\*\* DO NOT EXCEED VEHICLE MANUFACTURER'S RECOMMENDED TOWING CAPACITY. \*\*\***



Parts List			
ITEM	QTY	PART NUMBER	DESCRIPTION
1	6	1/2"	CONICAL TOOTHED WASHER
2	6	M12-1.25 x 30mm	HEX BOLT

TOOLS REQUIRED
RATCHET
MARKER
MASKING TAPE
12,18,19,21mm SOCKETS
TAPE MEASURE
TORQUE WRENCH
ROTARY TOOL
SAFETY GLASSES

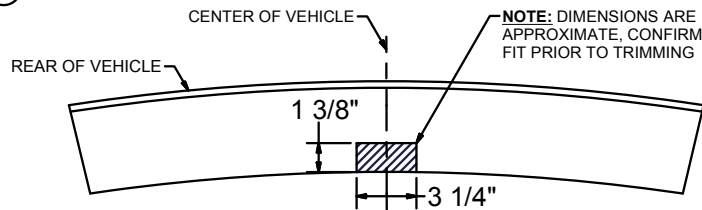
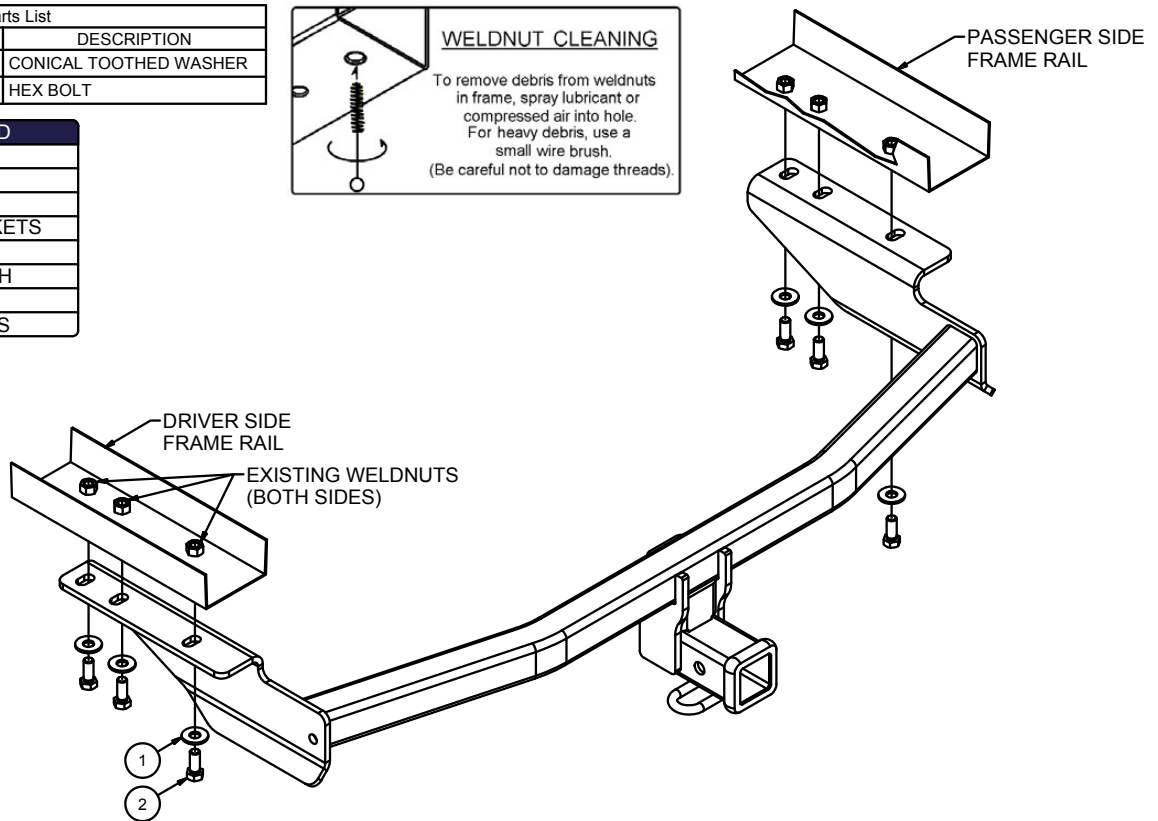
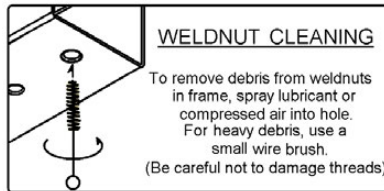

HITCH WEIGHT: 31 LBS.

**INSTALL TIME**

PROFESSIONAL: 40 MINUTES

NOVICE (DIY): 80 MINUTES

**INSTALL NOTES:**

- NO DRILLING REQUIRED
- MINOR FASCIA TRIM
- REMOVE TOW HOOK
- LOWER SPARE TIRE

## INSTALLATION STEPS

1. Remove tow hook from driver side frame rail using a 18mm socket to remove (4) bolts. Return tow hook and fasteners to vehicle owner.
2. Lower spare tire using tire lug wrench or ratchet with 21mm socket.
3. Remove fascia mounting brackets by first removing plastic clips on bottom of fascia and then unbolting brackets from bumper using a 12mm socket. Retain for reinstallation after hitch installation.
4. Mark area as shown for fascia trimming, approximately 3 1/4" x 1 3/8". Trim fascia.
5. Raise hitch into position and secure with M12-1.25 x 30mm hex bolts and 1/2" conical toothed washers into existing weldnuts using a 19mm socket. Torque all M12 fasteners to 86 ft-lbs.
6. Reinstall fascia mounting brackets.
7. Raise spare tire back into position.

**PERIODICALLY CHECK THIS RECEIVER HITCH TO ENSURE THAT ALL FASTENERS ARE TIGHT AND THAT ALL STRUCTURAL COMPONENTS ARE SOUND.**