

YEARS: 2016 - CURRENT

MAKE: BUICK

MODEL: ENVISION







STYLE: SUV

**WEIGHT CARRYING:**  
 TRAILER WEIGHT: 3,500 LBS.  
 TONGUE WEIGHT: 525 LBS.

**PRO INSTALL TIME: 20 MIN.**  
**NOVICE INSTALL TIME: 40 MIN.**

IF YOU ARE HESITANT TO UNDERTAKE THIS TASK ON YOUR OWN, CONTACT AN AUTHORIZED CURT INSTALLER FOR ADDITIONAL ASSISTANCE.



**INSTALLATION REQUIRES:**

 <b>FLAT HEAD SCREW DRIVER</b>	 <b>11/16" 15mm SOCKET</b>	 <b>RATCHET</b>
 <b>TORQUE WRENCH</b>	 <b>T15 TORXBIT SOCKET</b>	 <b>SAFETY GLASSES</b>

**INSTALLATION TIPS:**

- BEFORE YOU BEGIN INSTALLATION, READ ALL INSTRUCTIONS THOROUGHLY.
- TO EASE INSTALLATION, 2 PEOPLE MAY BE REQUIRED.
- USING PROPER TOOLS WILL GREATLY IMPROVE THE QUALITY OF THE INSTALL AND REDUCE THE TIME REQUIRED.

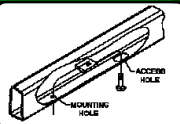
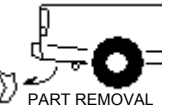
**LEVEL OF DIFFICULTY: EASY**

<i>EASY</i>	<i>MODERATE</i>	<i>CHALLENGING</i>
	FISHWIRE HARDWARE	
	TEMPORARILY REMOVE HITCH COVER PANEL	
	NO DRILLING REQUIRED	

**VEHICLE PHOTO:**



REPRESENTATIVE PHOTO

**HITCH ILLUSTRATION:**

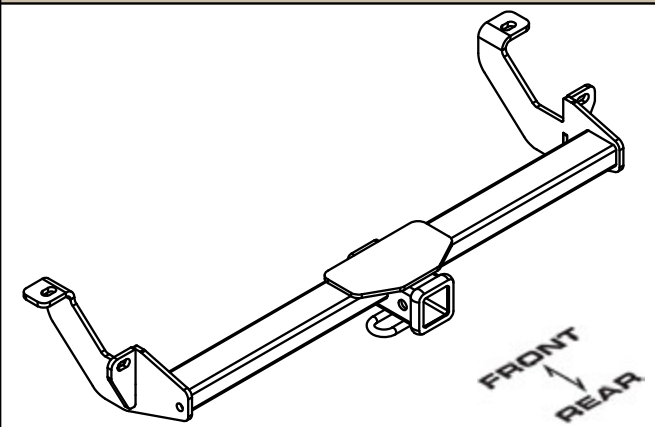

MAKE SURE YOUR HITCH MATCHES

## INSTALLATION WALKTHROUGH:

Parts List			
ITEM	QTY	PART NUMBER	DESCRIPTION
1	2	7/16-14 x 1 1/2	CARRIAGE BOLT
2	2	CM-SP2	.250 x .88 x 2.25" SQUARE HOLE SPACER
3	2	7/16-14	HEX FLANGE NUT
4	2	7_16 FISHWIRE	7/16" FISHWIRE

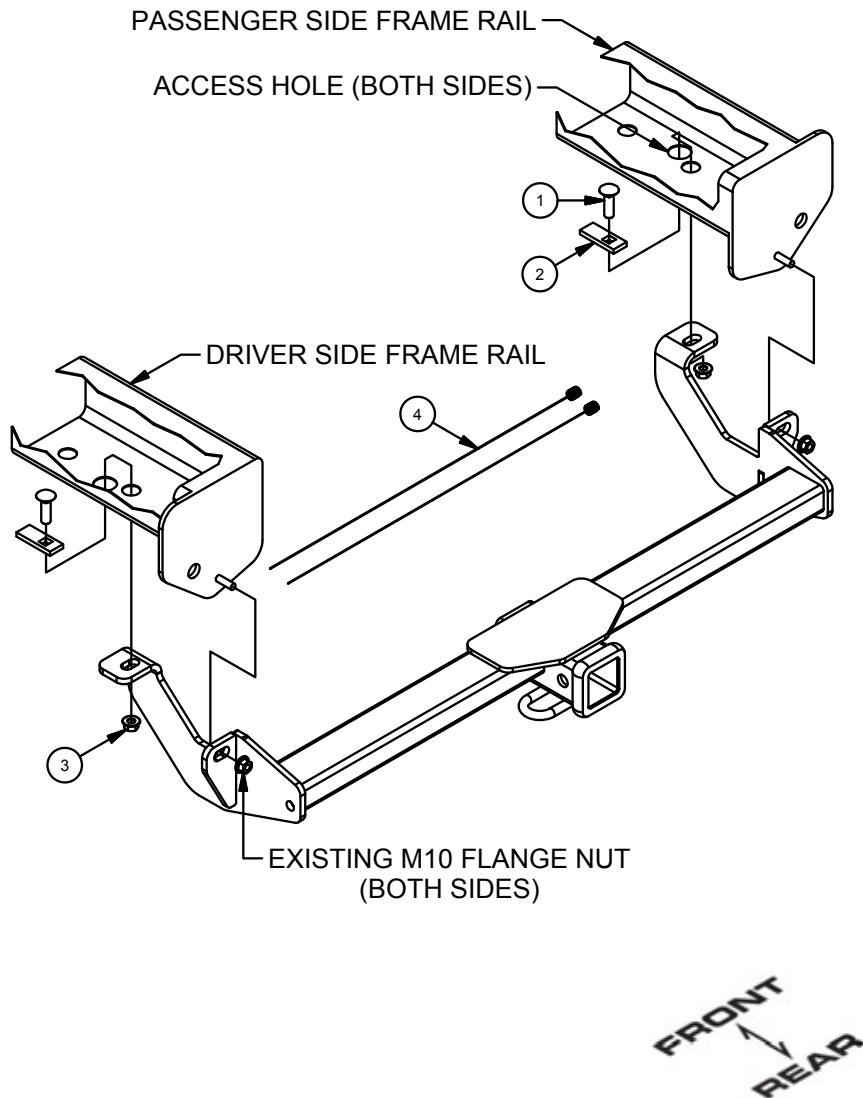

1. Remove (2) screws holding hitch cover panel to bumper using a T15 torxbit. Remove (5) fascia tabs along hitch cover panel using a flat head screw driver. Remove cover & save for optional re-installation.

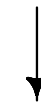

2. Remove (2) screws holding bumper fascia using a T15 torxbit. Save screws for re-installation. Use a 15mm deep well socket to remove (1) M10 flange nut from the bottom of driver side bumper beam attachment location & repeat on passenger side. Save nuts for re-installation.

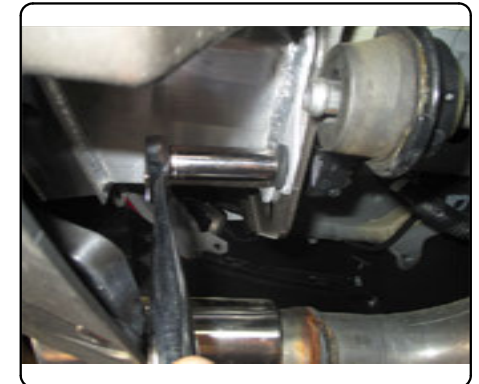

## INSTALLATION WALKTHROUGH:

3. Fishwire (1) 7/16" carriage bolt and (1) CM-SP2 in through access hole and out rearmost hole in driver & passenger side frame rail.

**FISHWIRE TECHNIQUE**  
INSERT COILED END OF FISHWIRE TOOL THROUGH HITCH MOUNTING HOLE IN VEHICLE FRAME RAIL AND OUT THE ACCESS HOLE. PASS COILED END OF FISHWIRE THROUGH SPACER AND THREAD BOLT INTO COIL. KINK WIRE TO KEEP SPACER SEPARATE FROM BOLT AS SHOWN. PULL FISHWIRE, SPACER, AND BOLT THROUGH FRAME AND OUT MOUNTING HOLE. USE FISHWIRE TO GUIDE HITCH DURING MOUNTING AND PREVENT LOSS OF BOLT / SPACER INSIDE FRAME RAIL.  
\*\*NOTE: SOME VEHICLES MAY FISHWIRE THROUGH END OF FRAME\*\*

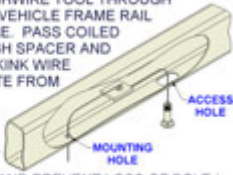

4. Gently pull fascia down and raise hitch into position guiding fishwires through mounting holes. NOTE: Hardware may need to be temporarily pushed into frame to position hitch over bumper beam studs. Remove fishwires & loosely secure 7/16 nuts. Secure existing M10 nuts onto bumper beam studs.

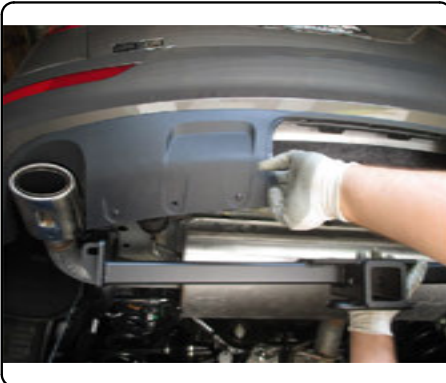

5. Torque all 7/16" hardware to 59 ft-lbs and all M10 hardware to 40 ft-lbs.



### OPTIONAL:

Re-install hitch panel cover removed in STEP 1. Secure screws with T15 torxbit socket.



## TOWING SAFETY INFORMATION

### Gross Trailer Weight / GTW

The Gross Trailer Weight is the weight of the trailer & cargo. Measure this by putting the fully loaded trailer on a vehicle scale.



### Tongue Weight / TW

The downward force that is exerted on the hitch ball by the coupler. The tongue weight will vary depending on where the load is positioned in relationship to the trailer axle(s). To measure the tongue weight, use either a commercial scale or a bathroom scale with the coupler at towing height. When using a bathroom scale with heavier tongue weights, use the method shown and multiply the scale reading by 3.

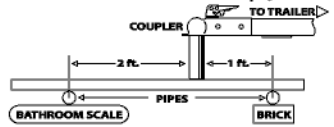

### Weight Carrying / WC

The total weight of both the trailer and the cargo inside. Never exceed the weight capacity of your trailer hitch.

### Weight Distribution / WD

Used to balance the weight of the cargo between the front and rear wheels throughout the trailer, allowing for better steering, braking, and level riding.



### Sway Control

A device used to reduce the lateral movements of the trailer that are caused by the wind. This works in conjunction with a weight distribution hitch. Do not use this on a class 1 or 2 hitch, or with surge brakes.

### How Much Can You Safely Tow?

TONGUE WEIGHT (lb)	1000	2000	3000	4000	5000	6000	7000	8000	10,000	12,000
Tongue weight should be about 10 to 15 percent of the gross trailer weight.										
TRAILER TYPE	<div style="display: flex; justify-content: space-between;"> <div style="width: 20%;">CLASS 1</div> <div style="width: 20%;">CLASS 2</div> <div style="width: 20%;">CLASS 3</div> <div style="width: 20%;">CLASS 4</div> <div style="width: 20%;">CLASS 5</div> </div>									
Camper	11'	12'	13'	14'	15'	16'				
lbs.	1100	1200	1300	1400	1500	1600				
Vacation	18'	19'	20'	21'	22'	24'	26'	28'	30'	32'
lbs.	2100	2400	2700	3000	3300	3600	3900	4200	4500	4800
Vacation	18'	19'	20'	21'	22'	24'	26'	28'	30'	32'
lbs.	2800	3200	3600	4000	4400	4800	5200	5600	6000	6400
5th Wheel										

**Refer to owner's manual for towing capabilities and limitations.**

### Ball Mount

The ball mount is placed inside the opening of the receiver hitch which is mounted to the vehicle. Make sure a hitch pin and clip is properly securing the ball mount to the receiver hitch before you begin towing.

- A: Rise. B: Drop. C: Hole Size. D: Length.



### Trailer Ball

The connection from the hitch to the trailer. There are many factors that determine the correct hitch ball:

- Number one is the hitch ball's gross trailer weight rating.
- The mounting platform must be at least 3/8" thick.
- The hole diameter must not be more than 1/16" larger than the threaded shank.
- Every time you tow, check the nut and lock washer to make sure they are fastened securely.
- A: Ball Dia. B: Shank Length. C: Shank Dia. D: Shank Rise.

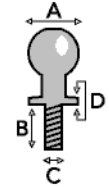

### Coupler

The component that is placed over the trailer ball to connect the vehicle to the trailer. Be sure that the coupler size matches the size of the hitch ball and that the coupler handle is securely fastened. To determine what size hitch ball you need for your application you will need to know the size of coupler that is on the trailer. Be sure your coupler is properly adjusted to the ball you are using.

NOTE: For added security the use of safety devices such as Coupler Safety Pins and Locks is strongly recommended.

### Safety Chains

Safety chains are a requirement and should be crossed under the tongue of the trailer so that the tongue will not drop to the road if it becomes separated from the hitch. Always leave enough slack so you can turn. Never allow the safety chains to drag on the ground and never attach the chains to the bumper.

Trailer Classification: Safety Chain Breaking Force - Minimum

Class 1: 2,000 lbs. (8.9 kN)

Class 2: 3,500 lbs. (15.6 kN)

Class 3: 5,000 lbs. (22.2 kN)

The strength rating of each length of safety chain or its equivalent and its attachments shall be equal to or exceed in minimum breaking force the GVWR (Gross Vehicle Weight Rating) of the trailer.

### Electrical

Trailer lights, Electric Brakes, Break-away systems - Every time you tow, be sure to check that all components are working properly.

Wiring identification by color:



CURT DISCLAIMER: WIRING COLOR SHOWN WORK IN CONJUNCTION WITH CURT MANUFACTURING PRODUCTS.

**13292****BUICK ENVISION****6/24/2016**

GROSS LOAD CAPACITY WHEN USED AS A WEIGHT CARRYING HITCH: 3,500 LBS. TRAILER WEIGHT & 525 LBS. TONGUE WEIGHT.  
 WARNING: ALL NON-TRAILER LOADS APPLIED TO THIS PRODUCT MUST BE SUPPORTED BY 18050 STABILIZING STRAPS.



**WARNING: \*\* FAILURE TO PROPERLY SUPPORT NON-TRAILER LOADS WILL VOID PRODUCT WARRANTY \*\***

**WARNING: \*\*\* DO NOT EXCEED VEHICLE MANUFACTURER'S RECOMMENDED TOWING CAPACITY \*\*\***



Parts List			
ITEM	QTY	PART NUMBER	DESCRIPTION
1	2	7/16-14 x 1 1/2	CARRIAGE BOLT
2	2	CM-SP2	.250 x .88 x 2.25" SQUARE HOLE SPACER
3	2	7/16-14	HEX FLANGE NUT
4	2	7_16 FISHWIRE	7/16" FISHWIRE

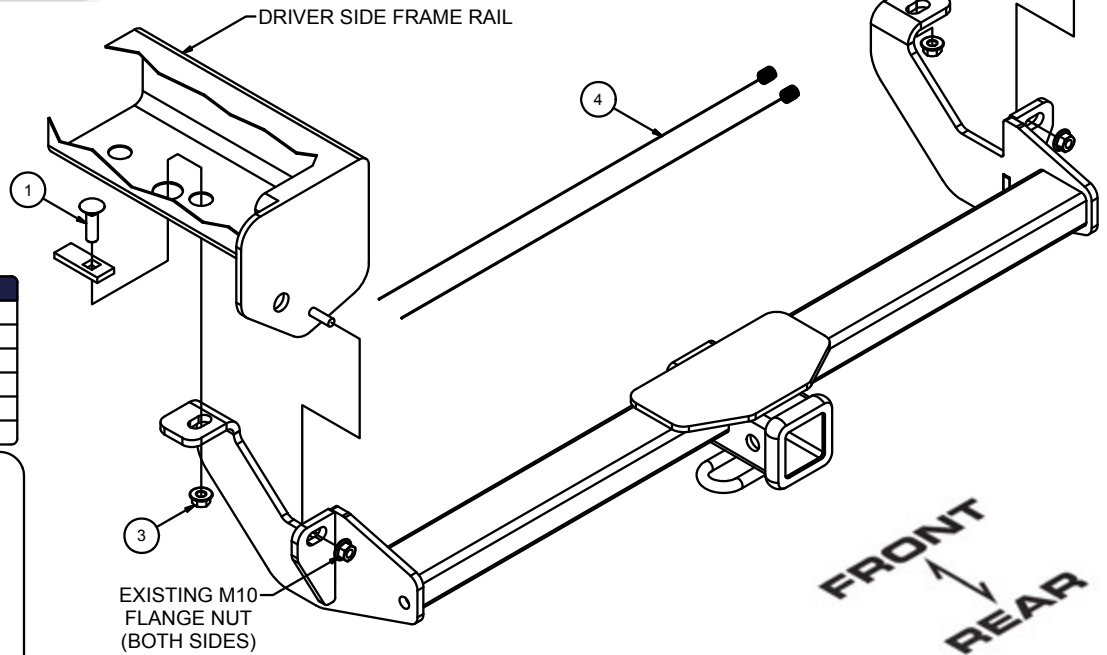
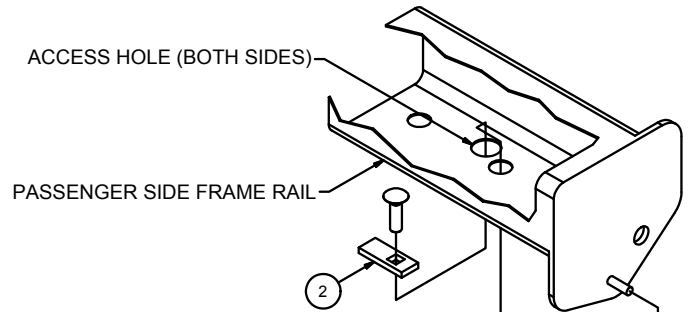
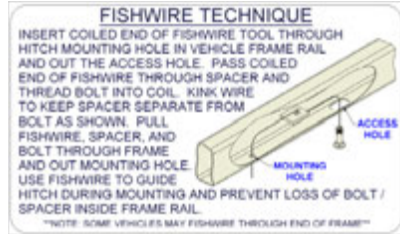

TOOLS REQUIRED
FLAT HEAD SCREW DRIVER
11/16" & 15mm SOCKETS
RATCHET
TORQUE WRENCH
T15 TORXBIT
SAFETY GLASSES

HITCH WEIGHT: 27 LBS.
INSTALL TIME
PROFESSIONAL: 20 MINUTES
NOVICE (DIY): 40 MINUTES
INSTALL NOTES:
- NO DRILLING REQUIRED
- FISHWIRE HARDWARE
- TEMPORARILY REMOVE HITCH COVER PANEL

**INSTALLATION STEPS**

1. Remove (2) screws holding hitch cover panel to bumper using a T15 torxbit. Remove (5) fascia tabs along hitch cover panel using a flat head screw driver. Remove cover & save for optional re-installation.
2. Remove (2) screws holding bumper fascia using a T15 torxbit. Save screws for re-installation. Use a 15mm deep well socket to remove (1) M10 flange nut from the bottom of driver side bumper beam attachment location & repeat on passenger side. Save nuts for re-installation.
3. Fishwire (1) 7/16" carriage bolt and (1) CM-SP2 in through access hole and out rearmost hole in driver & passenger side frame rail.
4. Gently pull fascia down and raise hitch into position guiding fishwires through mounting holes. NOTE: Hardware may need to be temporarily pushed into frame to position hitch over bumper beam studs. Remove fishwires & loosely secure 7/16 nuts. Secure existing M10 nuts onto bumper beam studs.
5. Torque all 7/16" hardware to 59 ft-lbs and all M10 hardware to 40 ft-lbs. OPTIONAL: Re-install hitch panel cover removed in STEP 1. Secure screws with T15 torxbit socket.

**PERIODICALLY CHECK THIS RECEIVER HITCH TO ENSURE THAT ALL FASTENERS ARE TIGHT AND THAT ALL STRUCTURAL COMPONENTS ARE SOUND.**