

YEARS: 2017-PRESENT

MAKE: JAGUAR

MODEL: F-PACE

STYLE: CUV

WARNING: NEVER EXCEED YOUR VEHICLE MANUFACTURER'S RECOMMENDED TOWING CAPACITY

WEIGHT CARRYING:
 TRAILER WEIGHT: 6,000 LBS.
 TONGUE WEIGHT: 900 LBS.

PRO INSTALL TIME: 60 MIN.
NOVICE INSTALL TIME: 120 MIN.

IF YOU ARE HESITANT TO UNDERTAKE THIS TASK ON YOUR OWN, CONTACT AN AUTHORIZED CURT INSTALLER FOR ADDITIONAL ASSISTANCE.

INSTALLATION REQUIRES:

RATCHET	TORQUE WRENCH	SOCKET EXTENSION 6"
SOCKET 8mm, 10mm, 21mm	T25 TORXBIT SOCKET	SCREW DRIVER
PLASTIC PRY TOOL	MASKING TAPE	AVIATION SHEARS
SAFETY GLASSES		

INSTALLATION TIPS:

- BEFORE YOU BEGIN INSTALLATION, READ ALL INSTRUCTIONS THOROUGHLY.
- TO EASE INSTALLATION, 2 PEOPLE MAY BE REQUIRED.
- USING PROPER TOOLS WILL GREATLY IMPROVE THE QUALITY OF THE INSTALL AND REDUCE THE TIME REQUIRED.

LEVEL OF DIFFICULTY: MODERATE

EASY	MODERATE	CHALLENGING
	TEMPORARILY REMOVE UNDERBODY PANEL AND BUMPER FASCIA	
	TRIMMING REQUIRED	

VEHICLE PHOTO:



REPRESENTATIVE PHOTO

HITCH ILLUSTRATION:

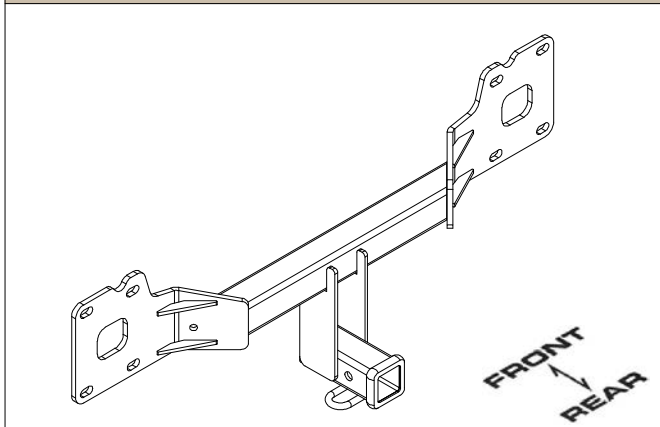

MAKE SURE YOUR HITCH MATCHES

INSTALLATION WALKTHROUGH:

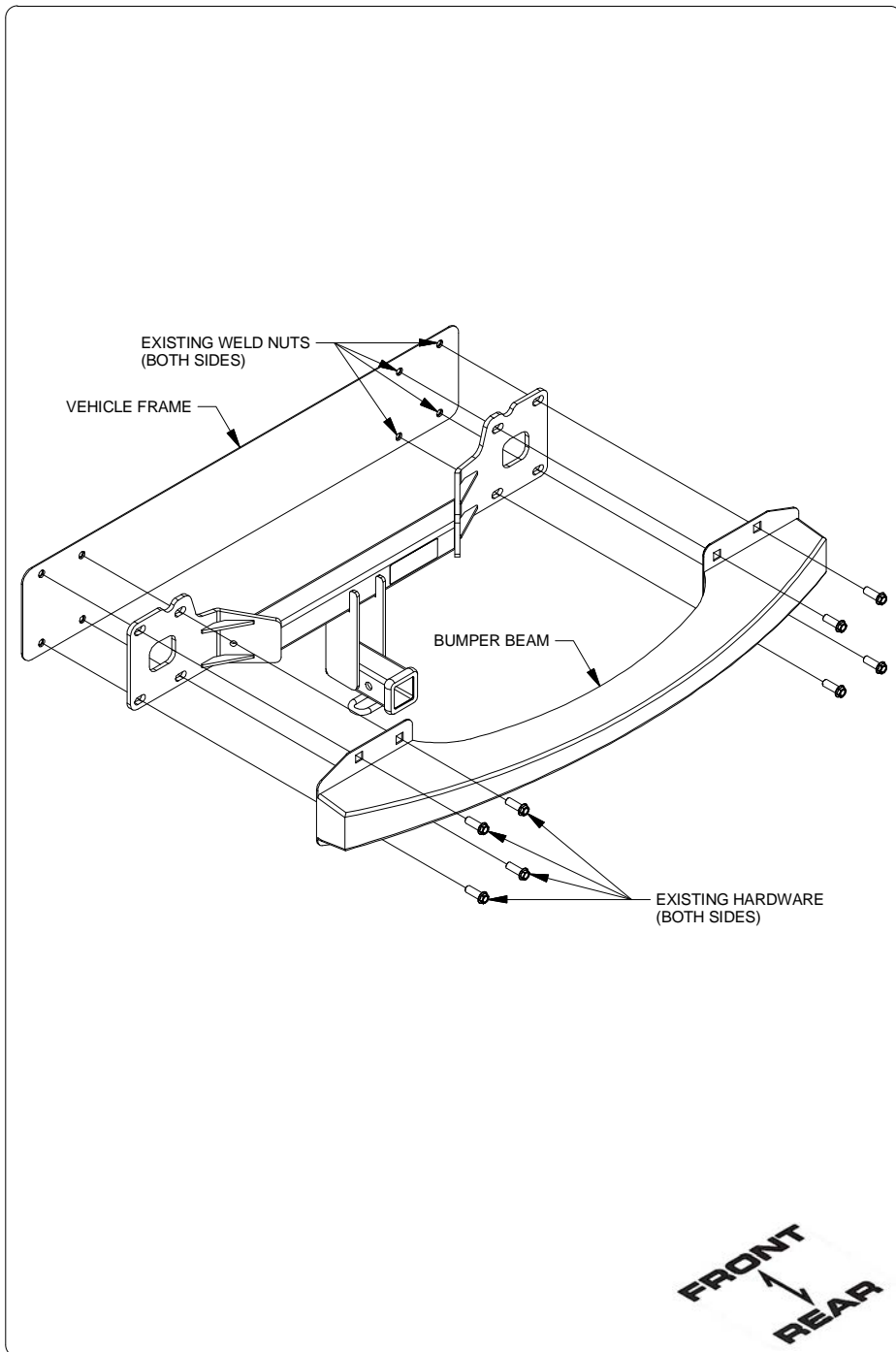

1. On the underbody panel, remove (3) screws using a 10mm socket and (4) screws using a screwdriver. Once removed, mark out a 3.25" x 6" section using masking tape and trim using aviation shears. Set aside for later reinstallation. NOTE: Dimensions are approximate, confirm prior to reinstallation.



2. Inside the wheel well, locate and remove (2) screws using a screwdriver. Once removed pull back wheel well to reveal (5) screws. Remove (2) using a T25 torxbit socket and (3) using a screwdriver. Set wheel well accent piece aside for later reinstallation.



INSTALLATION WALKTHROUGH:

3. Locate and remove plastic cover next to each tail light revealing (1) screw and remove using an 8mm socket. Locate on each side (1) plastic screw and remove using screwdriver. Use plastic pry tool to remove the rest of the plastic push pin. Set aside for later reinstallation.



4. Gently remove the bumper fascia starting at the outside of the vehicle and working towards the rear of the vehicle. Locate on the bumper fascia and unplug (2) electrical plugs. Set aside for later reinstallation.

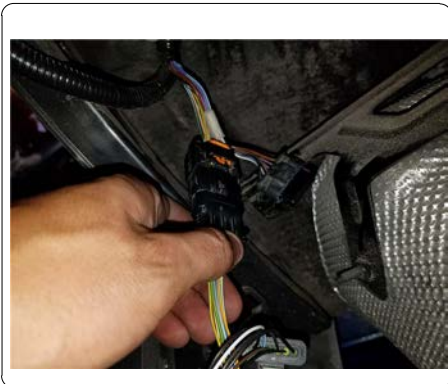
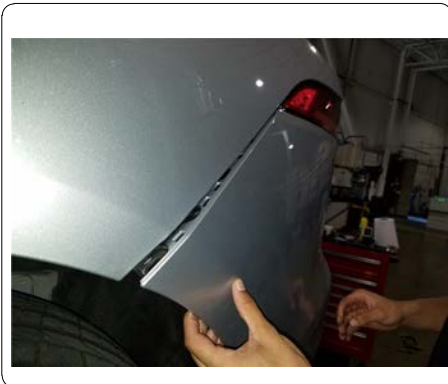

5. Locate along the panel and remove (5) screws using an 8mm socket. Next locate and remove (8) M14 bolts, (4) on each side of the bumper beam using a 21mm socket. Set both pieces aside for later reinstallation.



6. Raise hitch into position lining up the holes with the hole in the bumper beam and loosely fastening the (8) M14 bolts removed from Step 5. Torque the M14 bolts to 126 ft-lbs. Reinstall following steps 1-5 in reverse order.



TOWING SAFETY INFORMATION

Gross Trailer Weight / GTW

The Gross Trailer Weight is the weight of the trailer & cargo. Measure this by putting the fully loaded trailer on a vehicle scale.



Tongue Weight / TW

The downward force that is exerted on the hitch ball by the coupler. The tongue weight will vary depending on where the load is positioned in relationship to the trailer axle(s). To measure the tongue weight, use either a commercial scale or a bathroom scale with the coupler at towing height. When using a bathroom scale with heavier tongue weights, use the method shown and multiply the scale reading by 3.

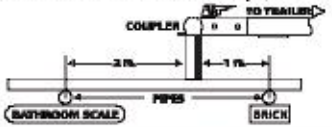

Weight Carrying / WC

The total weight of both the trailer and the cargo inside. Never exceed the weight capacity of your trailer hitch.

Weight Distribution / WD

Used to balance the weight of the cargo between the front and rear wheels throughout the trailer, allowing for better steering, braking, and level riding.



Sway Control

A device used to reduce the lateral movements of the trailer that are caused by the wind. This works in conjunction with a weight distribution hitch. Do not use this on a class 1 or 2 hitch, or with surge brakes.

How Much Can You Safely Tow?

TONGUE WEIGHT (lb)	1000	2000	3000	4000	5000	6000	7000	8000	10,000	12,000	
Tongue weight should be about 10% to 15% percent of the gross trailer weight.	CLASS 1										
	CLASS 2										
	CLASS 3										
	CLASS 4										
	CLASS 5										
TRAILER TYPE	11'	12'	13'	14'	15'	16'					
Coupler											
11c	1100	1200	1300	1400	1500	1600					
Weighted	14'	15'	16'	17'	18'	19'	20'	21'	22'	23'	
11c	2100	2400	2700	3000	3300	3600	3900	4200	4500	4800	
Weighted	14'	15'	16'	17'	18'	19'	20'	21'	22'	23'	
11c	2800	3200	3600	4000	4400	4800	5200	5600	6000	6400	
3-6 Wheel											

Refer to owner's manual for towing capabilities and limitations.

Ball Mount

The ball mount is placed inside the opening of the receiver hitch which is mounted to the vehicle. Make sure a hitch pin and clip is properly securing the ball mount to the receiver hitch before you begin towing.

• A: Rise. B: Drop. C: Hole Size. D: Length.

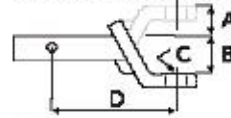

Trailer Ball

The connection from the hitch to the trailer. There are many factors that determine the correct hitch ball:

- Number one is the hitch ball's gross trailer weight rating.
- The mounting platform must be at least 3/8" thick.
- The hole diameter must not be more than 1/16" larger than the threaded shank.
- Every time you tow, check the nut and lock washer to make sure they are fastened securely.

• A: Ball Dia. B: Shank Dia. C: Shank Length. D: Shank Rise.



Coupler

The component that is placed over the trailer ball to connect the vehicle to the trailer. Be sure that the coupler size matches the size of the hitch ball and that the coupler handle is securely fastened. To determine what size hitch ball you need for your application you will need to know the size of coupler that is on the trailer. Be sure your coupler is properly adjusted to the ball you are using.

NOTE: For added security the use of safety devices such as Coupler Safety Pins and Locks is strongly recommended.

Safety Chains

Safety chains are a requirement and should be crossed under the tongue of the trailer so that the tongue will not drop to the road if it becomes separated from the hitch. Always leave enough slack so you can turn. Never allow the safety chains to drag on the ground and never attach the chains to the bumper.

Trailer Classification: Safety Chain Breaking Force - Minimum

Class 1: 2,000 lbs. (8.9 kN)

Class 2: 3,500 lbs. (15.6 kN)

Class 3: 5,000 lbs. (22.2 kN)

The strength rating of each length of safety chain or its equivalent and its attachments shall be equal to or exceed in minimum breaking force the GVWR (Gross Vehicle Weight Rating) of the trailer.

Electrical

Trailer lights, Electric Brakes, Break-away systems - Every time you tow, be sure to check that all components are working properly.

Wiring identification by color:



13291**JAGUAR F-PACE****GROSS LOAD CAPACITY WHEN USED AS A WEIGHT CARRYING HITCH: 6,000 LBS. TRAILER WEIGHT & 900 LBS. TONGUE WEIGHT.****WARNING: ALL NON-TRAILER LOADS APPLIED TO THIS PRODUCT MUST BE SUPPORTED BY 18050 STABILIZING STRAPS.****WARNING: ** FAILURE TO PROPERLY SUPPORT NON-TRAILER LOADS WILL VOID PRODUCT WARRANTY ******WARNING: *** DO NOT EXCEED VEHICLE MANUFACTURER'S RECOMMENDED TOWING CAPACITY *******TOOLS REQUIRED**

RATCHET

TORQUE WRENCH

6" SOCKET EXTENSION

8mm, 10mm, 21mm SOCKET

T25 TORXBIT SOCKET

PLASTIC PRY TOOL

SCREWDRIVER

MASKING TAPE

AVIATION SHEARS

SAFETY GLASSES

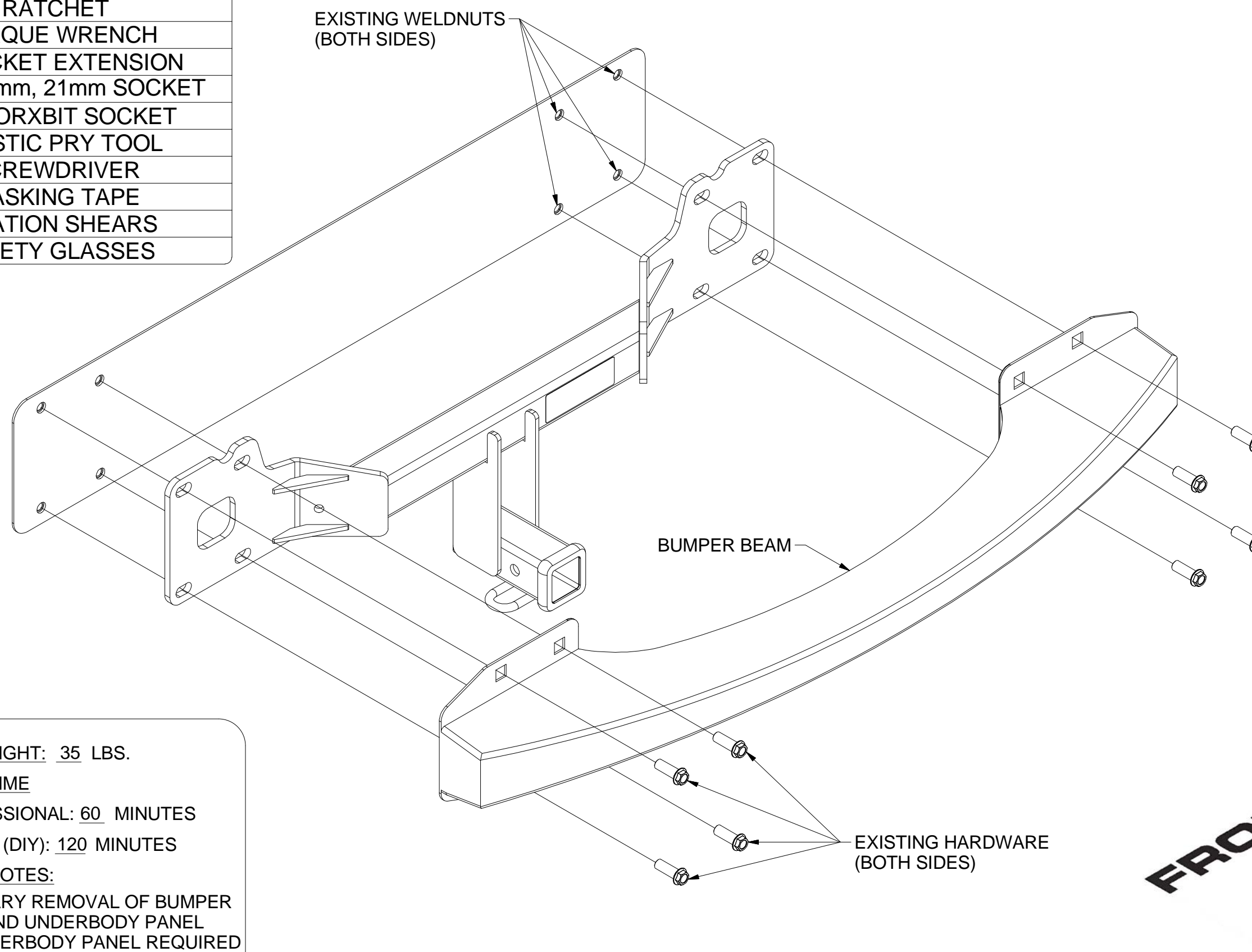

HITCH WEIGHT: 35 LBS.

INSTALL TIME

PROFESSIONAL: 60 MINUTES

NOVICE (DIY): 120 MINUTES

INSTALL NOTES:

- TEMPORARY REMOVAL OF BUMPER FASCIA AND UNDERBODY PANEL
- TRIM UNDERBODY PANEL REQUIRED

INSTALLATION STEPS

1. On the underbody panel, remove (3) screws using a 10mm socket and (4) screws using a screwdriver. Once removed, mark out a 3.25" x 6" section using masking tape and trim using aviation shears. Set aside for later reinstallation. NOTE: Dimensions are approximate, confirm prior to reinstallation.
2. Inside the wheel well, locate and remove (2) screws using a screwdriver. Once removed pull back wheel well to reveal (5) screws. Remove (2) screws using a T25 torxbit socket and (3) using a screwdriver. Set wheel well accent piece aside for later reinstallation.
3. Locate and remove plastic cover next to each tail light revealing (1) screw and remove using an 8mm socket. Locate on each side (1) plastic screw and remove using screwdriver. Use plastic pry tool to remove the rest of the plastic push pin. Set aside for later reinstallation.
4. Gently remove the bumper fascia starting at the outside of the vehicle and working towards the rear of the vehicle. Locate on the bumper fascia and unplug (2) electrical plugs. Set aside for later reinstallation.
5. Locate along the panel and remove (5) screws using an 8mm socket. Next locate and remove (8) M14 bolts, (4) on each side of the bumper beam using a 21mm socket. Set both pieces aside for later reinstallation.
6. Raise hitch into position lining up the holes with the hole in the bumper beam and loosely fastening the (8) M14 bolts removed from Step 5. Torque the M14 bolts to 126 ft-lbs. Reinstall following steps 1-5 in reverse order.

PERIODICALLY CHECK THIS RECEIVER HITCH TO ENSURE THAT ALL FASTENERS ARE TIGHT AND THAT ALL STRUCTURAL COMPONENTS ARE SOUND.