

YEARS: 2016-PRESENT

MAKE: MERCEDES

MODEL: MERTIS

STYLE: VAN

WEIGHT CARRYING: TRAILER WEIGHT: **6,000 LBS.**
TONGUE WEIGHT: **900 LBS.**

WEIGHT DISTRIBUTION: TRAILER WEIGHT: **6,000 LBS.**
TONGUE WEIGHT: **900 LBS.**

PRO INSTALL TIME: 15 MIN.
NOVICE INSTALL TIME: 30 MIN.

IF YOU ARE HESITANT TO UNDERTAKE THIS TASK ON YOUR OWN, CONTACT AN AUTHORIZED CURT INSTALLER FOR ADDITIONAL ASSISTANCE.

INSTALLATION TIPS:

- BEFORE YOU BEGIN INSTALLATION, READ ALL INSTRUCTIONS THOROUGHLY.
- TO EASE INSTALLATION, 2 PEOPLE MAY BE REQUIRED.
- USING PROPER TOOLS WILL GREATLY IMPROVE THE QUALITY OF THE INSTALL AND REDUCE THE TIME REQUIRED.



INSTALLATION REQUIRES:

| | | |
|----------------------------------|-----------------------|-------------------------------|
| RATCHET | TORQUE WRENCH | 16mm 18mm 3/4" |
| BOXED END WRENCH 18mm | SAFETY GLASSES | |
| | | |
| | | |

LEVEL OF DIFFICULTY: EASY

| EASY | MODERATE | CHALLENGING |
|--------------|-----------------|--------------------|
| NO DRILLING | | |
| PART REMOVAL | | |
| | | |
| | | |

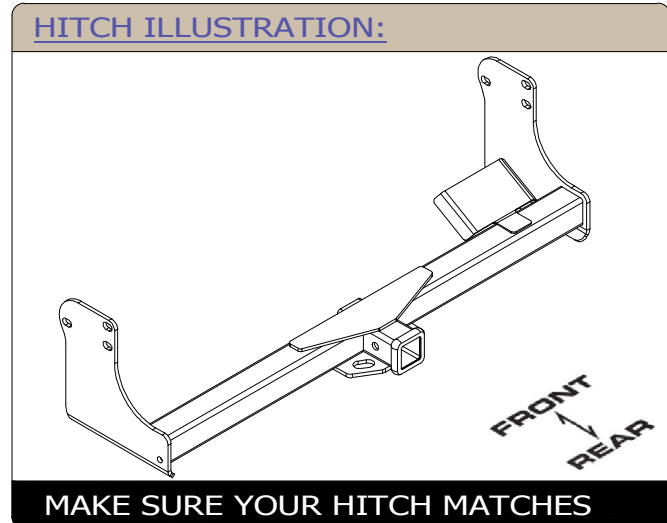

INSTALLATION WALKTHROUGH:

| Parts List | | | |
|------------|-----|---------------|------------------------|
| ITEM | QTY | PART NUMBER | DESCRIPTION |
| 1 | 6 | 1_2 - 13 x 4 | HEX BOLT |
| 2 | 6 | HFN 1213, GR8 | HEX FLANGE NUT |
| 3 | 6 | 1/2" | CONICAL TOOTHED WASHER |

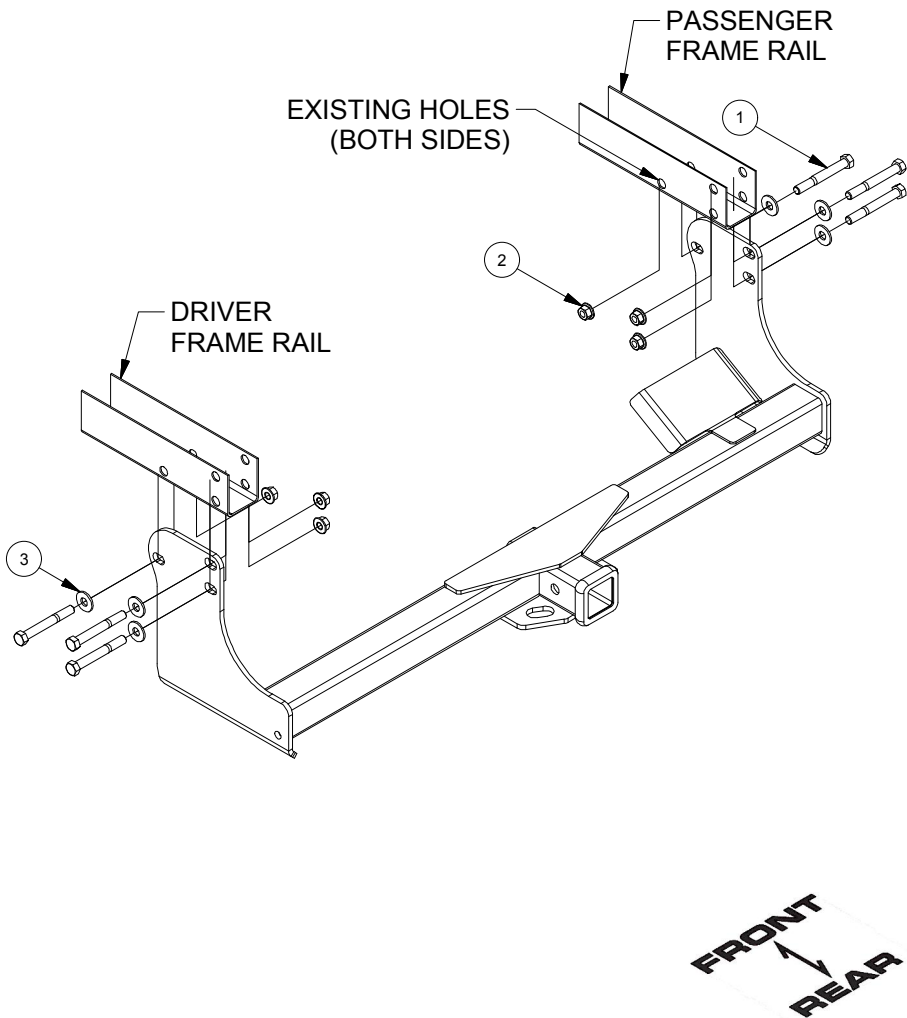

1. Locate tie-down loop on passenger frame rail and remove (2) M10 bolts on the bottom of the frame using a 16mm socket. Remove (2) M12 bolts on the inside of the frame using an 18mm socket and 18mm wrench. Return tie-down loop to owner.



- ↓
2. Raise hitch into position and loosely fasten provided hardware. Use 3/4" socket to torque all 1/2" fasteners to 110 ft-lbs.
Note: Lowering exhaust may ease installation.



TOWING SAFETY INFORMATION

Gross Trailer Weight / GTW

The Gross Trailer Weight is the weight of the trailer & cargo. Measure this by putting the fully loaded trailer on a vehicle scale.



Tongue Weight / TW

The downward force that is exerted on the hitch ball by the coupler. The tongue weight will vary depending on where the load is positioned in relationship to the trailer axle(s). To measure the tongue weight, use either a commercial scale or a bathroom scale with the coupler at towing height. When using a bathroom scale with heavier tongue weights, use the method shown and multiply the scale reading by 3.

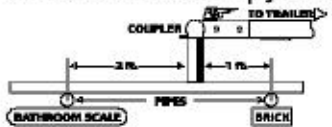

Weight Carrying / WC

The total weight of both the trailer and the cargo inside. Never exceed the weight capacity of your trailer hitch.

Weight Distribution / WD

Used to balance the weight of the cargo between the front and rear wheels throughout the trailer, allowing for better steering, braking, and level riding.



Sway Control

A device used to reduce the lateral movements of the trailer that are caused by the wind. This works in conjunction with a weight distribution hitch. Do not use this on a class 1 or 2 hitch, or with surge brakes.

How Much Can You Safely Tow?

| TONGUE WEIGHT (lb.) | 1500 | 2000 | 2500 | 3000 | 3500 | 4000 | 4500 | 5000 | 5500 | 6000 | 6500 | 7000 | 7500 | 8000 | 8500 | 9000 | 9500 | 10,000 | |
|---------------------|---------|------|------|------|------|------|------|------|------|------|------|------|------|------|------|------|------|--------|--|
| CLASS 1 | CLASS 1 | | | | | | | | | | | | | | | | | | |
| CLASS 2 | CLASS 2 | | | | | | | | | | | | | | | | | | |
| CLASS 3 | CLASS 3 | | | | | | | | | | | | | | | | | | |
| CLASS 4 | CLASS 4 | | | | | | | | | | | | | | | | | | |
| CLASS 5 | CLASS 5 | | | | | | | | | | | | | | | | | | |
| Coupler | 11 | 12 | 13 | 14 | 15 | 16 | | | | | | | | | | | | | |
| Inc. | 1100 | 1200 | 1300 | 1400 | 1500 | 1600 | | | | | | | | | | | | | |
| Weight | 17 | 18 | 19 | 20 | 21 | 22 | 23 | 24 | 25 | 26 | 27 | 28 | 29 | 30 | 31 | | | | |
| Inc. | 2100 | 2400 | 2700 | 3000 | 3300 | 3600 | 3900 | 4200 | 4500 | 4800 | | | | | | | | | |
| Weight | 17 | 18 | 19 | 20 | 21 | 22 | 23 | 24 | 25 | 26 | 27 | 28 | 29 | 30 | 31 | | | | |
| Inc. | 2800 | 3200 | 3600 | 4000 | 4400 | 4800 | 5200 | 5600 | 6000 | 6400 | | | | | | | | | |
| 5th Wheel | | | | | | | | | | | | | | | | | | | |

Refer to owner's manual for towing capabilities and limitations.

Ball Mount

The ball mount is placed inside the opening of the receiver hitch which is mounted to the vehicle. Make sure a hitch pin and clip is properly securing the ball mount to the receiver hitch before you begin towing.

- A: Rise. B: Drop. C: Hole Size. D: Length.

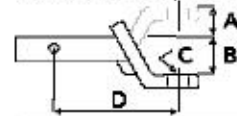

Trailer Ball

The connection from the hitch to the trailer. There are many factors that determine the correct hitch ball:

- Number one is the hitch ball's gross trailer weight rating.
- The mounting platform must be at least 3/8" thick.
- The hole diameter must not be more than 1/16" larger than the threaded shank.
- Every time you tow, check the nut and lock washer to make sure they are fastened securely.
- A: Ball Dia. B: Shank Length. C: Shank Dia. D: Shank Rise.

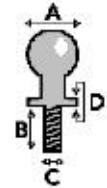

Coupler

The component that is placed over the trailer ball to connect the vehicle to the trailer. Be sure that the coupler size matches the size of the hitch ball and that the coupler handle is securely fastened. To determine what size hitch ball you need for your application you will need to know the size of coupler that is on the trailer. Be sure your coupler is properly adjusted to the ball you are using.

NOTE: For added security the use of safety devices such as Coupler Safety Pins and Locks is strongly recommended.

Safety Chains

Safety chains are a requirement and should be crossed under the tongue of the trailer so that the tongue will not drop to the road if it becomes separated from the hitch. Always leave enough slack so you can turn. Never allow the safety chains to drag on the ground and never attach the chains to the bumper.

Trailer Classification: Safety Chain Breaking Force - Minimum

Class 1: 2,000 lbs. (8.9 kN)

Class 2: 3,500 lbs. (15.6 kN)

Class 3: 5,000 lbs. (22.2 kN)

The strength rating of each length of safety chain or its equivalent and its attachments shall be equal to or exceed in minimum breaking force the GVWR (Gross Vehicle Weight Rating) of the trailer.

Electrical

Trailer lights, Electric Brakes, Break-away systems - Every time you tow, be sure to check that all components are working properly.

Wiring identification by color:



CURT DISCLAIMER: WIRING COLOR SHOWN WORK IN CONJUNCTION WITH CURT MANUFACTURING PRODUCTS.

13276

MERCEDES METRIS

5/4/2016

GROSS LOAD CAPACITY WHEN USED AS A WEIGHT CARRYING HITCH: 6,000 LBS. TRAILER WEIGHT & 900 LBS. TONGUE WEIGHT.
GROSS LOAD CAPACITY WHEN USED AS A WEIGHT DISTRIBUTION HITCH: 6,000 LBS. TRAILER WEIGHT & 900 LBS. TONGUE WEIGHT

| Parts List | | | |
|------------|---|---------------|------------------------|
| I | Q | PART NUMBER | DESCRIPTION |
| 1 | 6 | 1_2 - 13 x 4 | HEX BOLT |
| 2 | 6 | HFN 1213, GR8 | HEX FLANGE NUT |
| 3 | 6 | 1/2" | CONICAL TOOTHED WASHER |

| TOOLS REQUIRED | |
|----------------|--|
| RATCHET | |
| TORQUE WRENCH | |
| 16mm SOCKET | |
| 18mm SOCKET | |
| 3/4" SOCKET | |
| 18mm WRENCH | |
| SAFETY GLASSES | |

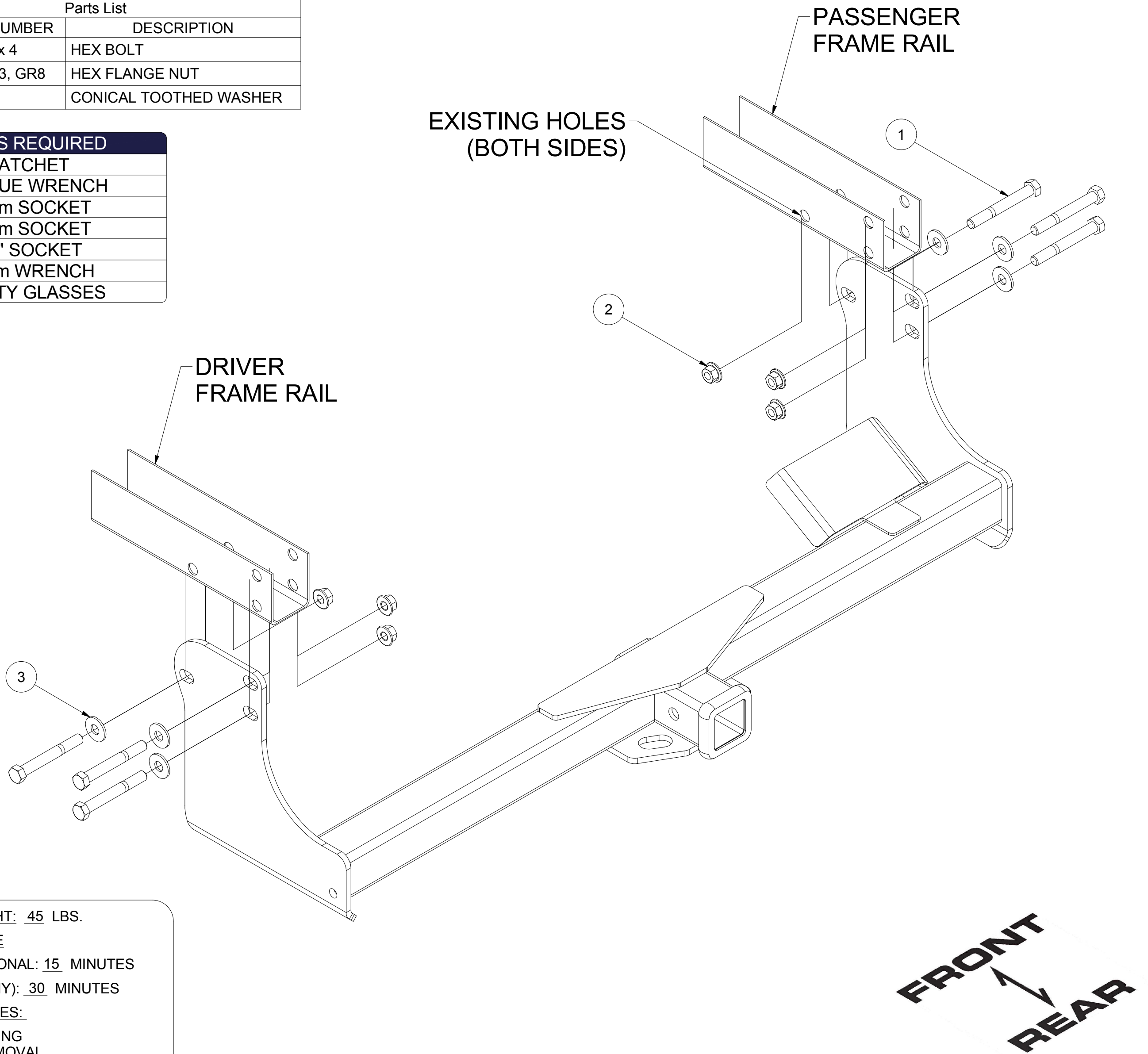

HITCH WEIGHT: 45 LBS.

INSTALL TIME

PROFESSIONAL: 15 MINUTES

NOVICE (DIY): 30 MINUTES

INSTALL NOTES:

- NO DRILLING
- PART REMOVAL

INSTALLATION STEPS

1. Locate tie-down loop on passenger frame rail and remove (2) M10 bolts on the bottom of the frame using a 16mm socket. Remove (2) M12 bolts on the inside of the frame using an 18mm socket and 18mm wrench. Return tie-down loop to owner.
2. Raise hitch into position and loosely fasten provided hardware. Use 3/4" socket and torque all 1/2" fasteners to 110 ft-lbs.

Note: Lowering exhaust may ease installation.

PERIODICALLY CHECK THIS RECEIVER HITCH TO ENSURE THAT ALL FASTENERS ARE TIGHT AND THAT ALL STRUCTURAL COMPONENTS ARE SOUND.