

YEARS: 2017-PRESENT

MAKE: FORD

MODEL: FUSION (SPORT)

STYLE: SEDAN

WARNING: NEVER EXCEED YOUR VEHICLE MANUFACTURER'S RECOMMENDED TOWING CAPACITY

WEIGHT CARRYING:
 TRAILER WEIGHT: 3500 LBS.
 TONGUE WEIGHT: 350 LBS.

PRO INSTALL TIME: 20 MIN.
NOVICE INSTALL TIME: 40 MIN.

IF YOU ARE HESITANT TO UNDERTAKE THIS TASK ON YOUR OWN, CONTACT AN AUTHORIZED CURT INSTALLER FOR ADDITIONAL ASSISTANCE.

INSTALLATION REQUIRES:

RATCHET	TORQUE WRENCH	SOCKET
SAFETY GLASSES	PRY BAR	

INSTALLATION TIPS:

- BEFORE YOU BEGIN INSTALLATION, READ ALL INSTRUCTIONS THOROUGHLY.
- TO EASE INSTALLATION, 2 PEOPLE MAY BE REQUIRED.
- USING PROPER TOOLS WILL GREATLY IMPROVE THE QUALITY OF THE INSTALL AND REDUCE THE TIME REQUIRED.

LEVEL OF DIFFICULTY: EASY

EASY	MODERATE	CHALLENGING
	NO DRILLING REQUIRED	
	PERMANENTLY REMOVE LOWER REAR AIR DEFLECTOR	
	FISHWIRING REQUIRED	
	LOWER EXHAUST BY REMOVING (3) ISOLATORS	
	TEMPORARILY REMOVE HEAT SHIELD	

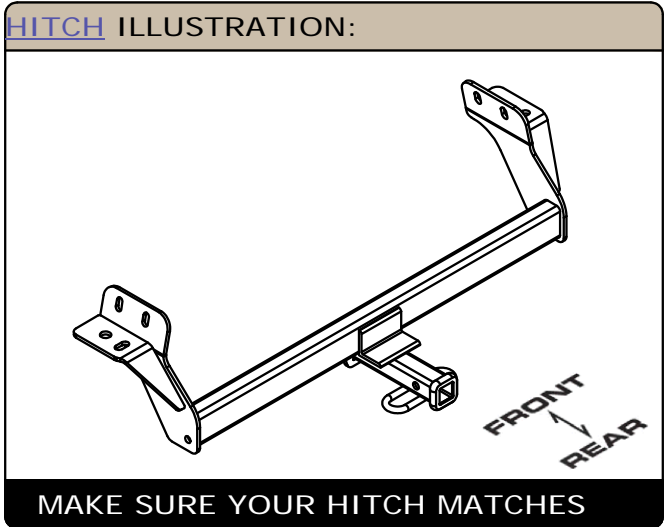

INSTALLATION WALKTHROUGH:

Parts List			
ITEM	QTY	PART NUMBER	DESCRIPTION
1	2	HFN 1213, GR8	HEX FLANGE NUT
2	2	1/2-13 x 1 1/2, GR8	CARRIAGE BOLT
3	2	CM-SP10	.250 x 1.00 x 2.50" SQUARE HOLE SPACER
4	2	1_2 FISHWIRE	1/2" FISHWIRE
5	4	7_16 FISHWIRE	7/16" FISHWIRE
6	4	7_16 - 14 x 1 1_4 CARRIAGE (GRADE 8)	CARRIAGE BOLT
7	4	7/16-14	HEX FLANGE NUT
8	4	CM-SP11	.250 x 1.00 x 2.50" SQUARE HOLE SPACER

FISHWIRE TECHNIQUE
 INSERT COILED END OF FISHWIRE TOOL THROUGH HITCH MOUNTING HOLE IN VEHICLE FRAME RAIL AND OUT THE ACCESS HOLE. PASS COILED END OF FISHWIRE THROUGH SPACER AND THREAD BOLT INTO COIL. KINK WIRE TO KEEP SPACER SEPARATE FROM BOLT AS SHOWN. PULL FISHWIRE, SPACER, AND BOLT THROUGH FRAME AND OUT MOUNTING HOLE. USE FISHWIRE TO GUIDE HITCH DURING MOUNTING AND PREVENT LOSS OF BOLT / SPACER INSIDE FRAME RAIL.
 NOTE: SOME VEHICLES MAY FISHWIRE THROUGH END OF FRAME

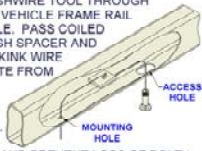

RUBBER ISOLATOR REMOVAL DIAGRAM
 This technique can be used if an Exhaust Hanger Removal Pliers is not available.
 Using a 5/8" open end wrench, slide the wrench up to the rubber isolator, cradling the hanger rod as shown. Next place the flat edge of a pry bar between the wrench and the hanger stop or hanger rod. Then simply rotate the pry bar toward the wrench to remove the rubber isolator.
 Note: Using a spray lubricant or soapy water on the hanger rod and the rubber isolator helps removal.

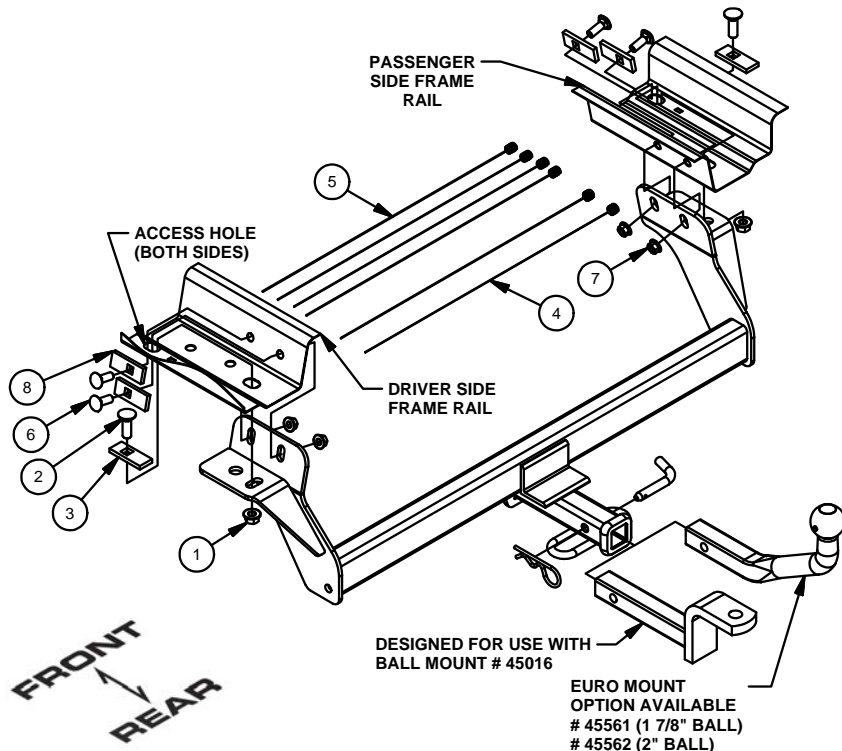

1. Remove lower rear air deflector by removing (3) formed nuts and (1) plastic nut with a 10mm socket. Next remove the (6) screw with washer fasteners in the bumper fascia with a 7mm socket. Return fascia piece and hardware to vehicle owner.

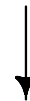

2. Lower the muffler by removing (3) exhaust hangers, (1) from each side and (1) in front of the muffler. Temporarily remove heat shield by removing (9) formed nuts with a 10mm socket.

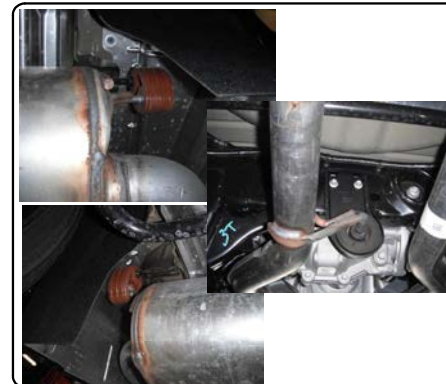

INSTALLATION WALKTHROUGH:

3. Fishwire the 1/2" bolts and spacer blocks through the access hole in both frame rails for the bottom frame hole and the 7/16" bolts and spacers blocks through the same hole and into the side mounting holes. Leave fishwires on all fasteners and the 7/16" bolts in the frame until the hitch is in position.

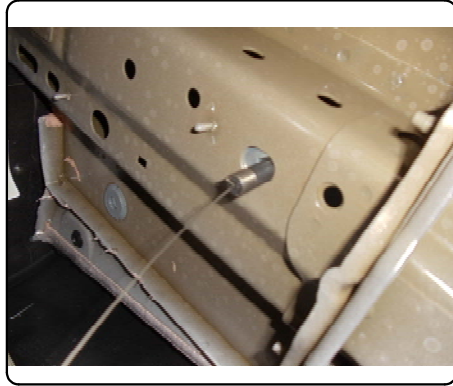

4. Raise hitch into position and secure with 1/2" flange nuts and 7/16" flange nuts using 3/4" and 11/16" sockets respectively.



5. Torque all 7/16" fasteners to 70 lb.-ft and all 1/2" fasteners to 110 lb.-ft. Reinstall heat shield and exhaust removed in step 2.



TOWING SAFETY INFORMATION

Gross Trailer Weight / GTW

The Gross Trailer Weight is the weight of the trailer & cargo. Measure this by putting the fully loaded trailer on a vehicle scale.



Tongue Weight / TW

The downward force that is exerted on the hitch ball by the coupler. The tongue weight will vary depending on where the load is positioned in relationship to the trailer axle(s). To measure the tongue weight, use either a commercial scale or a bathroom scale with the coupler at towing height. When using a bathroom scale with heavier tongue weights, use the method shown and multiply the scale reading by 3.

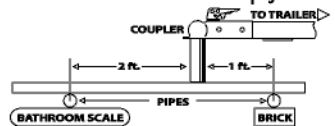

Weight Carrying / WC

The total weight of both the trailer and the cargo inside. Never exceed the weight capacity of your trailer hitch.

Weight Distribution / WD

Used to balance the weight of the cargo between the front and rear wheels throughout the trailer, allowing for better steering, braking, and level riding.



Sway Control

A device used to reduce the lateral movements of the trailer that are caused by the wind. This works in conjunction with a weight distribution hitch. Do not use this on a class 1 or 2 hitch, or with surge brakes.

How Much Can You Safely Tow?

TONGUE WEIGHT lbs	1000	2000	3000	4000	5000	6000	7000	8000	10,000	12,000
CLASS 1	[Bar]									
CLASS 2	[Bar]									
CLASS 3	[Bar]									
CLASS 4	[Bar]									
CLASS 5	[Bar]									
TRAILER TYPE										
Camper	11'	12'	13'	14'	15'	16'				
lbs	1100	1200	1300	1400	1500	1600				
Vacation	14'	16'	18'	20'	22'	24'	26'	28'	30'	32'
lbs	2100	2400	2700	3000	3300	3600	3900	4200	4500	4800
Vacation	14'	16'	18'	20'	22'	24'	26'	28'	30'	32'
lbs	2800	3200	3600	4000	4400	4800	5200	5600	6000	6400
5th Wheel										

Refer to owner's manual for towing capabilities and limitations.

Ball Mount

The ball mount is placed inside the opening of the receiver hitch which is mounted to the vehicle. Make sure a hitch pin and clip is properly securing the ball mount to the receiver hitch before you begin towing.

- A: Rise. B: Drop. C: Hole Size. D: Length.

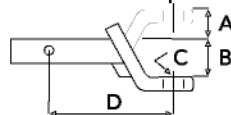

Trailer Ball

The connection from the hitch to the trailer. There are many factors that determine the correct hitch ball:

- Number one is the hitch ball's gross trailer weight rating.
- The mounting platform must be at least 3/8" thick.
- The hole diameter must not be more than 1/16" larger than the threaded shank.
- Every time you tow, check the nut and lock washer to make sure they are fastened securely.
- A: Ball Dia. B: Shank Length. C: Shank Dia. D: Shank Rise.

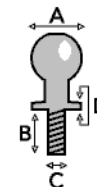

Coupler

The component that is placed over the trailer ball to connect the vehicle to the trailer. Be sure that the coupler size matches the size of the hitch ball and that the coupler handle is securely fastened. To determine what size hitch ball you need for your application you will need to know the size of coupler that is on the trailer. Be sure your coupler is properly adjusted to the ball you are using.

NOTE: For added security the use of safety devices such as Coupler Safety Pins and Locks is strongly recommended.

Safety Chains

Safety chains are a requirement and should be crossed under the tongue of the trailer so that the tongue will not drop to the road if it becomes separated from the hitch. Always leave enough slack so you can turn. Never allow the safety chains to drag on the ground and never attach the chains to the bumper.

Trailer Classification: Safety Chain Breaking Force - Minimum

Class 1: 2,000 lbs. (8.9 kN)

Class 2: 3,500 lbs. (15.6 kN)

Class 3: 5,000 lbs. (22.2 kN)

The strength rating of each length of safety chain or its equivalent and its attachments shall be equal to or exceed in minimum breaking force the GVWR (Gross Vehicle Weight Rating) of the trailer.

Electrical

Trailer lights, Electric Brakes, Break-away systems - Every time you tow, be sure to check that all components are working properly.

Wiring identification by color:

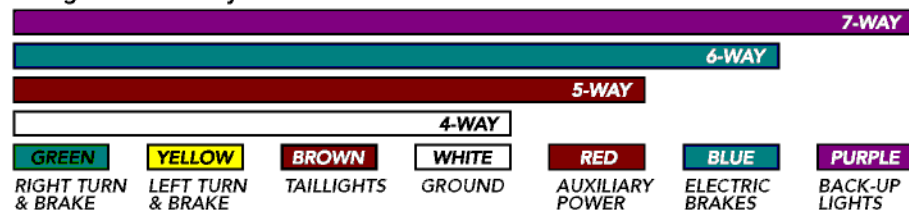

CURT DISCLAIMER: WIRING COLOR SHOWN WORK IN CONJUNCTION WITH CURT MANUFACTURING PRODUCTS.

12164

FORD FUSION SPORT

GROSS LOAD CAPACITY WHEN USED AS A WEIGHT CARRYING HITCH: 3500 LBS. TRAILER WEIGHT & 350 LBS. TONGUE WEIGHT.

WARNING: ALL NON-TRAILER LOADS APPLIED TO THIS PRODUCT MUST BE SUPPORTED BY 18050 STABILIZING STRAPS.

WARNING: ** FAILURE TO PROPERLY SUPPORT NON-TRAILER LOADS WILL VOID PRODUCT WARRANTY **

WARNING: * DO NOT EXCEED VEHICLE MANUFACTURER'S RECOMMENDED TOWING CAPACITY *****



Parts List			
ITEM	QTY	PART NUMBER	DESCRIPTION
1	4	7_16 FISHWIRE	7/16" FISHWIRE
2	2	1_2 FISHWIRE	1/2" FISHWIRE
3	4	CM-SP11	.250 x 1.00 x 2.50" SQUARE HOLE SPACER
4	4	7_16 - 14 x 1 1_4 CARRIAGE (GRADE 8)	CARRIAGE BOLT
5	2	1/2-13 x 1 1/2, GR8	CARRIAGE BOLT
6	2	CM-SP10	.250 x 1.00 x 2.50" SQUARE HOLE SPACER
7	2	HFN 1213, GR8	HEX FLANGE NUT
8	4	7/16-14	HEX FLANGE NUT

TOOLS REQUIRED

7mm & 10mm SOCKET

11/16" & 3/4" SOCKET

RATCHET

TORQUE WRENCH

PRY BAR

FISHWIRE TECHNIQUE

INSERT COILED END OF FISHWIRE TOOL THROUGH HITCH MOUNTING HOLE IN VEHICLE FRAME RAIL AND OUT THE ACCESS HOLE. PASS COILED END OF FISHWIRE THROUGH SPACER AND THREAD BOLT INTO COIL. KINK WIRE TO KEEP SPACER SEPERATE FROM BOLT AS SHOWN. PULL FISHWIRE, SPACER, AND BOLT THROUGH FRAME AND OUT MOUNTING HOLE. USE FISHWIRE TO GUIDE HITCH DURING MOUNTING AND PREVENT LOSS OF BOLT / SPACER INSIDE FRAME RAIL.

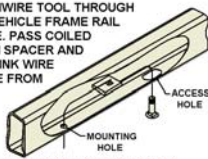

NOTE: SOME VEHICLES MAY FISHWIRE THROUGH END OF FRAME

RUBBER ISOLATOR REMOVAL DIAGRAM

This technique can be used if an Exhaust Hanger Removal Pliers is not available.

Using a 5/8" open end wrench, slide the wrench up to the rubber isolator, cradling the hanger rod as shown. Next place the flat edge of a pry bar between the wrench and the hanger stop or hanger rod. Then simply rotate the pry bar toward the wrench to remove the rubber isolator.

Note: Using a spray lubricant or soapy water on the hanger rod and the rubber isolator helps removal.

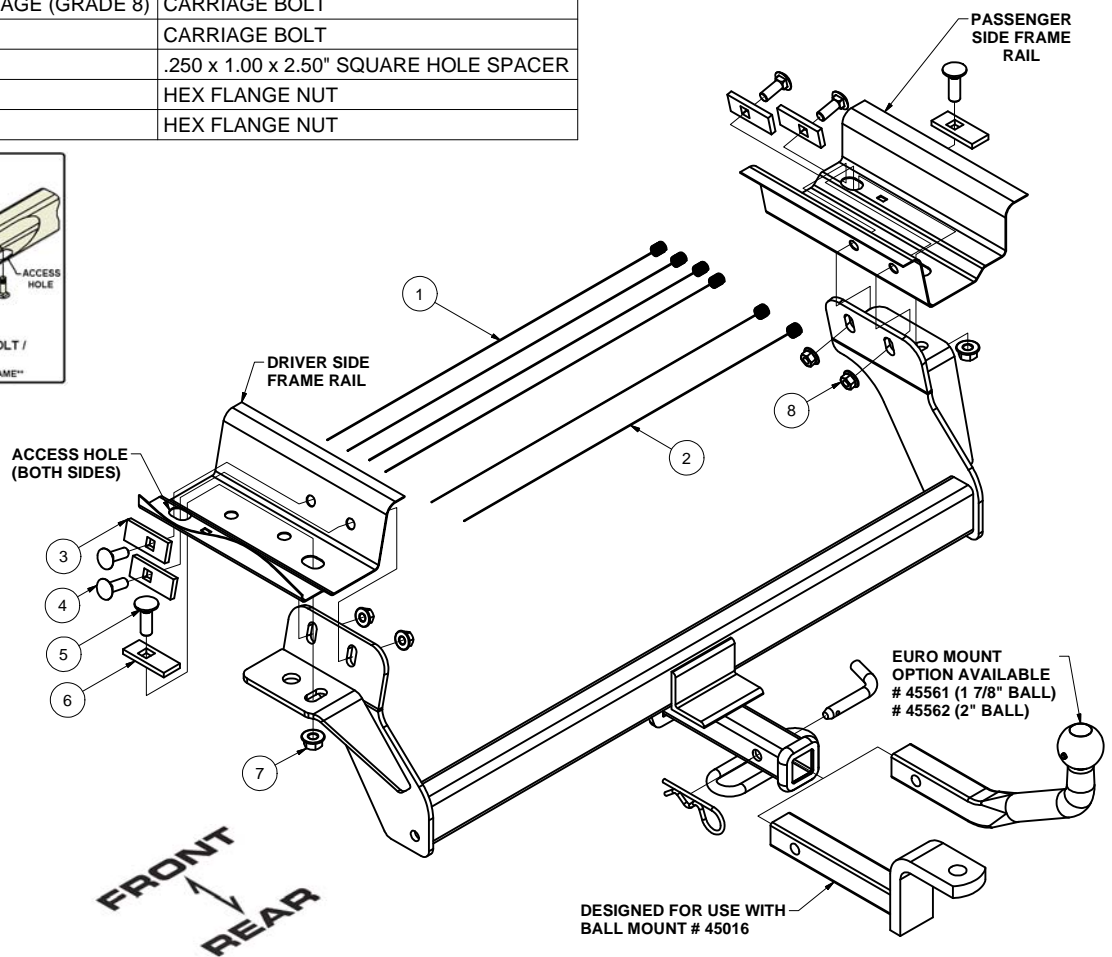

HITCH WEIGHT: 26 LBS.

INSTALL TIME

PROFESSIONAL: 20 MINUTES

NOVICE (DIY): 40 MINUTES

INSTALL NOTES:

- REMOVE LOWER AIR DEFLECTOR
- LOWER EXHAUST AND HEAT SHIELD
- FISHWIRING REQ.
- NO DRILL REQ.

INSTALLATION STEPS

1. Remove lower air deflector by removing (3) formed nuts and (1) plastic nut with a 10mm socket. Next remove the (6) screw with washer fasteners in the bumper fascia with a 7mm socket. Return fascia piece and hardware to vehicle owner.
2. Lower the muffler by removing (3) exhaust hangers, (1) from each side and (1) in front of the muffler. Temporarily remove heat shield by removing (9) formed nuts with a 10mm socket.
3. Fishwire the 1/2" bolts and spacer blocks though the access hole in both frame rails for the bottom frame hole and the 7/16" bolts and spacers blocks through the same hole and into the side mounting holes. Leave fishwires on all fasteners and the 7/16" bolts in the frame until the hitch is in position.
4. Raise hitch into position and secure with 1/2" flange nuts and 7/16" flange nuts using 3/4" and 11/16" sockets respectively.
5. Torque all 7/16" fasteners to 70 lb.-ft and all 1/2" fasteners to 110 lb.-ft. Reinstall heat shield and exhaust removed in step 2.

PERIODICALLY CHECK THIS RECEIVER HITCH TO ENSURE THAT ALL FASTENERS ARE TIGHT AND THAT ALL STRUCTURAL COMPONENTS ARE SOUND.