

12156

MAZDA CX-9

4/25/2016

GROSS LOAD CAPACITY WHEN USED AS A WEIGHT CARRYING HITCH: 3500 LBS. TRAILER WEIGHT & 350 LBS. TONGUE WEIGHT.

WARNING: ALL NON-TRAILER LOADS APPLIED TO THIS PRODUCT MUST BE SUPPORTED BY 18050 STABILIZING STRAPS.

**WARNING: ** FAILURE TO PROPERLY SUPPORT NON-TRAILER LOADS WILL VOID PRODUCT WARRANTY ******WARNING: *** DO NOT EXCEED VEHICLE MANUFACTURER'S RECOMMENDED TOWING CAPACITY *****

Parts List			
ITEM	QTY	PART NUMBER	DESCRIPTION
1	4	1/2-13 x 1 1/2, GR8	CARRIAGE BOLT
2	4	HFN 1213, GR8	HEX FLANGE NUT
3	4	CM-SP6	.250 x 1.00 x 3.00" SQUARE HOLE SPACER
4	4	1_2 FISHWIRE	1/2" FISHWIRE

FISHWIRE TECHNIQUE

INSERT COILED END OF FISHWIRE TOOL THROUGH HITCH MOUNTING HOLE IN VEHICLE FRAME RAIL AND OUT THE ACCESS HOLE. PASS COILED END OF FISHWIRE THROUGH SPACER AND THREAD BOLT INTO COIL. KINK WIRE TO KEEP SPACER SEPERATE FROM BOLT AS SHOWN. PULL FISHWIRE, SPACER, AND BOLT THROUGH FRAME AND OUT MOUNTING HOLE. USE FISHWIRE TO GUIDE HITCH DURING MOUNTING AND PREVENT LOSS OF BOLT / SPACER INSIDE FRAME RAIL.

"NOTE: SOME VEHICLES MAY FISHWIRE THROUGH END OF FRAME"

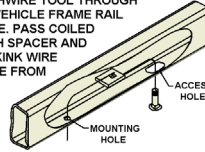
**REVERSE PULL FISHWIRE TECHNIQUE**

ATTACH FISHWIRE TO CARRIAGE BOLT AND SLIDE SPACER ONTO FISHWIRE. PUSH THE BOLT THRU THE HOLE FOLLOWED BY THE SPACER (AS SHOWN). PULL BOLT BACK INTO POSITION, PROTRUDING FROM THE FRAME.

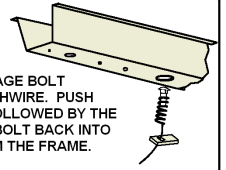
**RUBBER ISOLATOR REMOVAL DIAGRAM**

This technique can be used if an Exhaust Hanger Removal Pliers is not available.

Using a 5/8" open end wrench, slide the wrench up to the rubber isolator, cradling the hanger rod as shown. Next place the flat edge of a pry bar between the wrench and the hanger stop or hanger rod. Then simply rotate the pry bar toward the wrench to remove the rubber isolator.

Note: Using a spray lubricant or soapy water on the hanger rod and the rubber isolator helps removal.

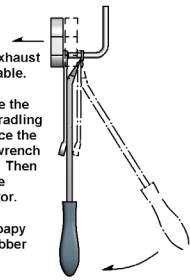
**TOOLS REQUIRED**

RATCHET
10mm & 3/4" SOCKET
TORQUE WRENCH
FLAT HEAD SCREWDRIVER
6" SOCKET EXTENSION
SAFETY GLASSES

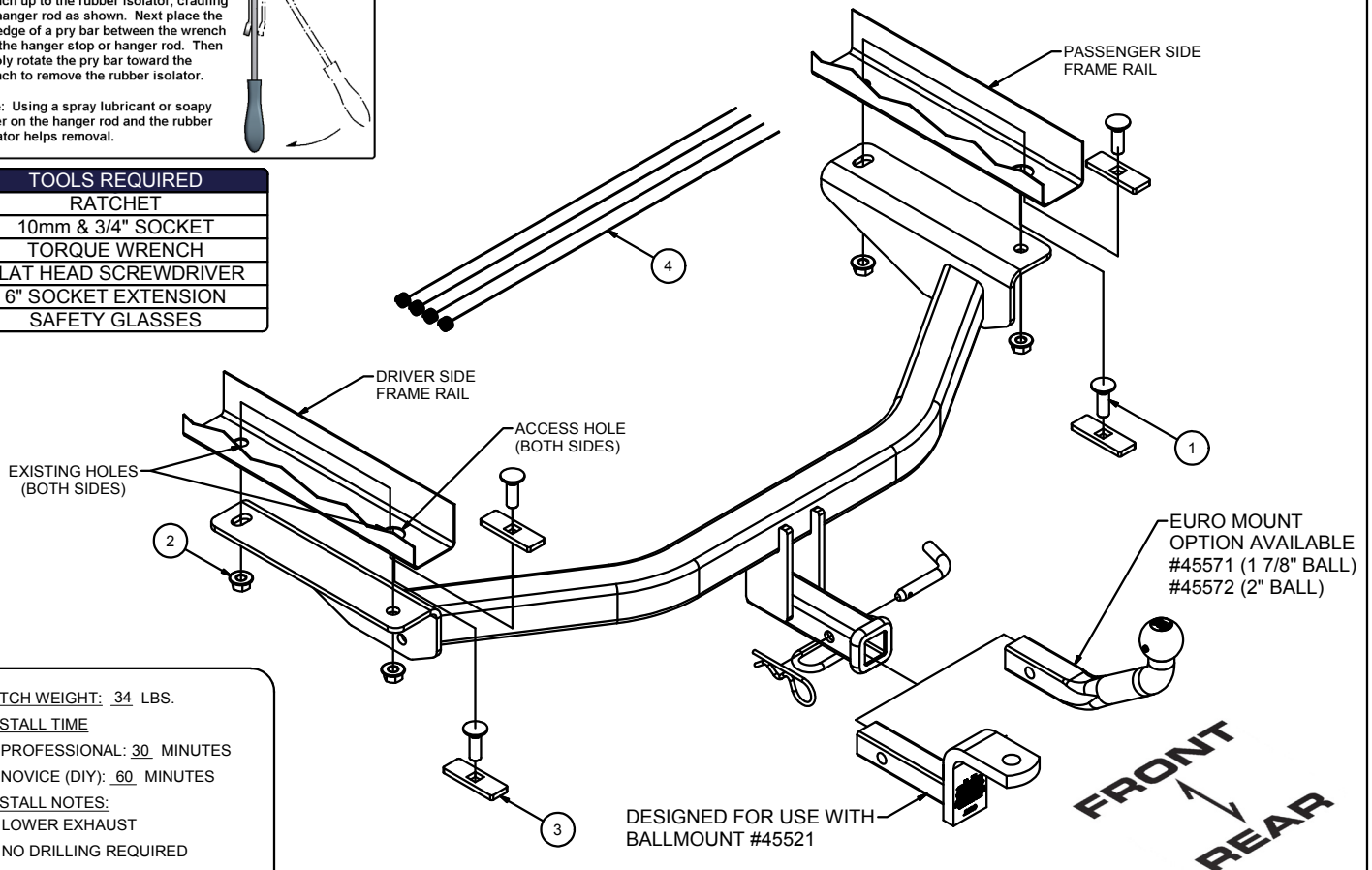

HITCH WEIGHT: 34 LBS.

INSTALL TIME

PROFESSIONAL: 30 MINUTES

NOVICE (DIY): 60 MINUTES

INSTALL NOTES:

LOWER EXHAUST

NO DRILLING REQUIRED

REMOVE PANEL

INSTALLATION STEPS

1. Remove lower trim panel from vehicle by removing (2) plastic fasteners using a flathead screw driver and (2) hex nuts using a 10mm socket. Return trim panel to owner.
2. Remove (4) rubber exhaust hangers using exhaust removal pliers or method shown above. Make sure exhaust is supported.
3. Fishwire (1) 1/2" carriage bolt and (1) CM-SP6 through access hole and into forward-most hole in each frame rail. Leave fishwires attached.
4. Reverse fishwire (1) 1/2" carriage bolt and (1) CM-SP6 through access hole in each frame rail. Leave fishwires attached.
5. Raise hitch into position guiding fishwire ends through attachment holes. Remove fishwires and secure hitch with 1/2" hex flange nuts.
6. Torque all 1/2" fasteners to 110 ft-lbs. Raise exhaust back into position and re-install exhaust hangers.

PERIODICALLY CHECK THIS RECEIVER HITCH TO ENSURE THAT ALL FASTENERS ARE TIGHT AND THAT ALL STRUCTURAL COMPONENTS ARE SOUND.

