



# 11454 INSTALLATION INSTRUCTIONS

Safety glasses should be worn at all times while installing this product.

YEARS: 2017-PRESENT

MAKE: MERCEDES-BENZ

MODEL: E300

STYLE: SEDAN

**WARNING: NEVER EXCEED YOUR VEHICLE MANUFACTURER'S RECOMMENDED TOWING CAPACITY**

**WEIGHT CARRYING:**  
**TRAILER WEIGHT:** 2,000 LBS.  
**TONGUE WEIGHT:** 200 LBS.

**WARNING:**  
WE RECOMMEND THE USE OF 18050 STABILIZING STRAPS FOR ALL NON-TRAILER (WHEEL-LESS) LOADS.

**PRO INSTALL TIME:** 45 MIN.  
**NOVICE INSTALL TIME:** 90 MIN.  
IF YOU ARE HESITANT TO UNDERTAKE THIS TASK ON YOUR OWN, CONTACT AN AUTHORIZED CURT INSTALLER FOR ADDITIONAL ASSISTANCE.

**INSTALLATION TIPS:**  
1. BEFORE YOU BEGIN INSTALLATION, READ ALL INSTRUCTIONS THOROUGHLY.  
2. TO EASE INSTALLATION, 2 PEOPLE MAY BE REQUIRED.  
3. USING PROPER TOOLS WILL GREATLY IMPROVE THE QUALITY OF THE INSTALL AND REDUCE THE TIME REQUIRED.



**INSTALLATION REQUIRES:**

<b>RATCHET</b>	<b>TORQUE WRENCH</b>	<b>6" SOCKET EXTENSION</b>
<b>E12 8mm 10mm 11/16" SOCKET</b>	<b>T25 TORXBIT T40 SOCKET</b>	<b>DIE GRINDER</b>
<b>POWER DRILL</b>	<b>DRILL BIT 1/2"</b>	<b>MARKER</b>
<b>MASKING TAPE</b>	<b>AVIATION SHEARS</b>	<b>SAFETY GLASSES</b>

**LEVEL OF DIFFICULTY: MODERATE**

EASY	MODERATE	CHALLENGING
	<b>LOWER EXHUAST</b>	
	<b>TEMPORARILY REMOVE EXHAUST TIPS AND HEAT SHIELDS</b>	
	<b>TRIM REQUIRED</b>	
	<b>DRILLING REQUIRED</b>	
	<b>HOLE ENLARGEMENT REQUIRED</b>	

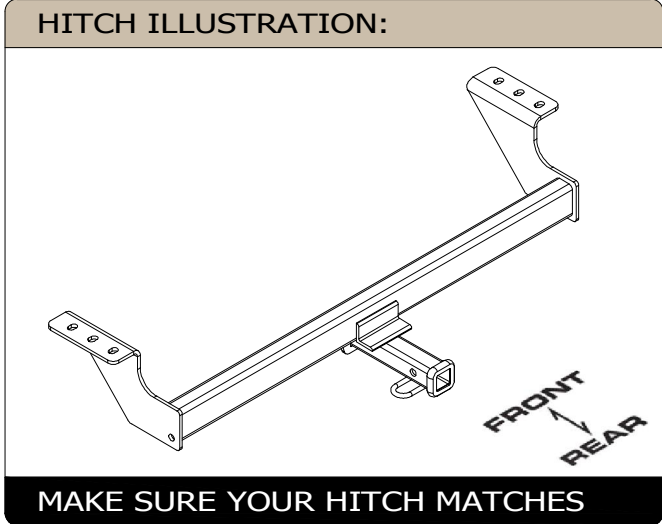

**PERIODICALLY CHECK THIS RECEIVER HITCH TO ENSURE ALL FASTENERS ARE TIGHT AND ALL STRUCTURAL COMPONENTS ARE SOUND**  
CURT Manufacturing LLC. warrants this product to be free of defects in material and/or workmanship at the time of retail purchase by the original purchaser. If the product is found to be defective, CURT Manufacturing LLC. may repair or replace the product at their option, when the product is returned, prepaid, with proof of purchase. Alteration to, misuse of, or improper installation of this product voids the warranty. CURT Manufacturing LLC.'s liability is limited to repair or replacement of products found to be defective, and specifically excludes liability for incidental or consequential loss or damage.

## INSTALLATION WALKTHROUGH:

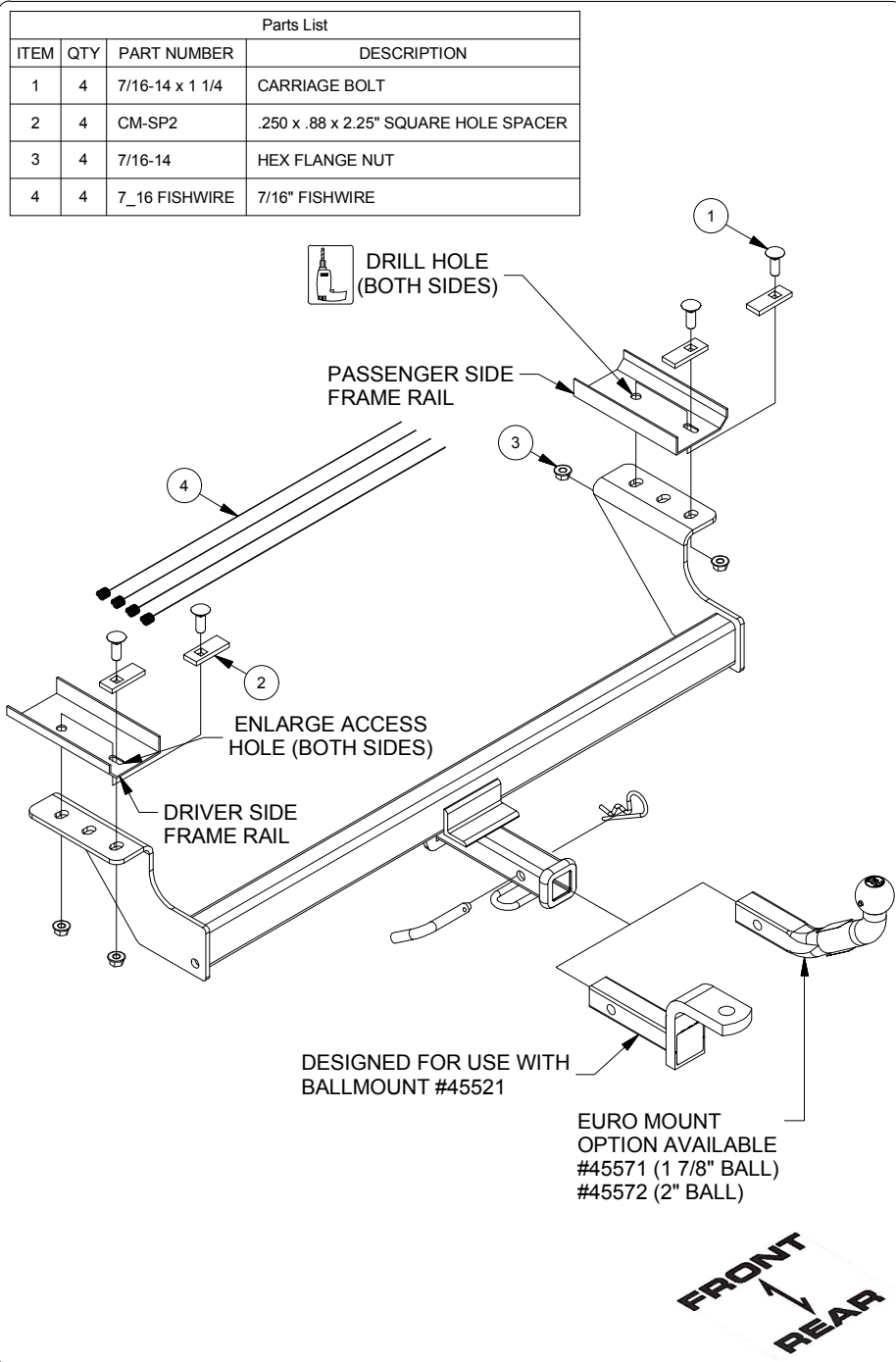

1. Locate on the exhaust tips (6) bolts, (3) on each tip, and remove using a T40 torxbit socket. Remove exhaust tips and set aside for later reinstallation.



2. To lower exhaust, remove (2) bolts using an E12 socket from the exhaust bracket on each side. Locate and remove (2) rubber isolators from the exhaust towards the front of the vehicle.

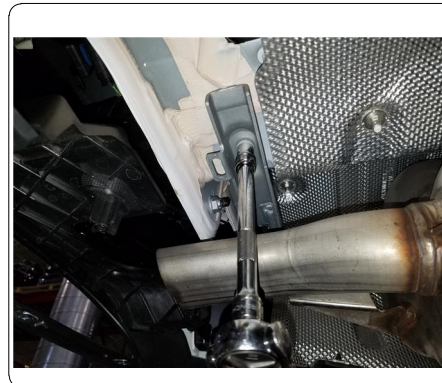



## INSTALLATION WALKTHROUGH:

3. On the heat shields, locate and remove (4) nuts using an 8mm socket, (2) bolts using a 10mm socket, (2) screws using a T25 torxbit socket, and (1) metal clip from the heat shield on each side. Set aside for later reinstallation.

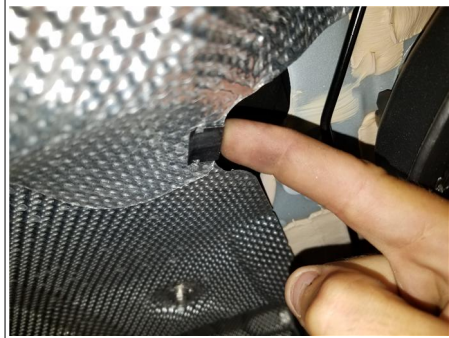

4. On the heat shields mark out a 4" x 8" section using masking tape and trim out using aviation shears. Reinstall heat shields using hardware from Step 3.

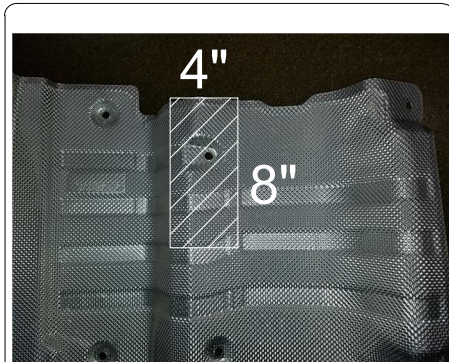

5. Raise hitch into position aligning the rear-most hole of the hitch with the existing hole on the frame to use as a template to mark out the forward most hole on each side of the hitch. Lower hitch and drill out the marked areas using a 1/2" drill bit. **NOTE:** for ease of drilling push the exhaust towards the side of the vehicle.



6. Use the die grinder to enlarge the slotted hole to a 1.125" hole. Verify that provided bolt head will fit through hole before moving on to next step.

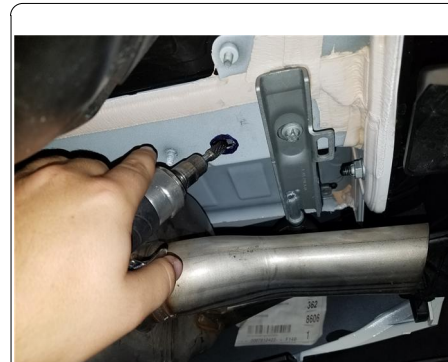

## INSTALLATION WALKTHROUGH:

7. Fishwire (1) 7/16" carriage bolt and (1) CM-SP2 spacer through the enlarged access hole to the forward most hole in the frame on each side. Reverse fishwire (1) 7/16" carriage bolt and (1) CM-SP2 spacer through the enlarged access hole on each frame rail.

### FISHWIRE TECHNIQUE

INSERT COILED END OF FISHWIRE TOOL THROUGH HITCH MOUNTING HOLE IN VEHICLE FRAME RAIL AND OUT THE ACCESS HOLE. PASS COILED END OF FISHWIRE THROUGH SPACER AND THREAD BOLT INTO COIL. KINK WIRE TO KEEP SPACER SEPARATE FROM BOLT AS SHOWN. PULL FISHWIRE, SPACER, AND BOLT THROUGH FRAME AND OUT MOUNTING HOLE. USE FISHWIRE TO GUIDE HITCH DURING MOUNTING AND PREVENT LOSS OF BOLT / SPACER INSIDE FRAME RAIL.

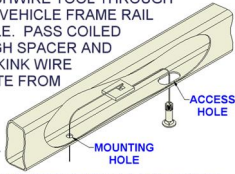

### REVERSE PULL FISHWIRE TECHNIQUE

ATTACH FISHWIRE TO CARRIAGE BOLT AND SLIDE SPACER ONTO FISHWIRE. PUSH THE BOLT THRU THE HOLE FOLLOWED BY THE SPACER (AS SHOWN). PULL BOLT BACK INTO POSITION, PROTRUDING FROM THE FRAME.

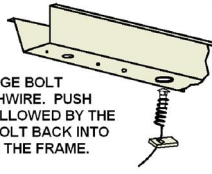

9. Torque all 7/16" hardware to 59 ft-lbs. Reinstall exhaust tips and raise exhaust following Step 1-2 in reverse order.



8. Raise hitch into position feeding the fishwires through the holes in the hitch. Once hitch is in place, remove fishwires and loosely fasten (2) 7/16" hex flange nuts on each side.

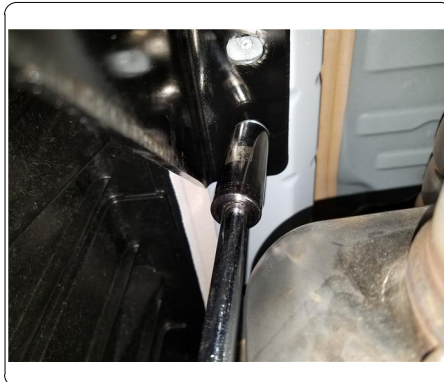



## TOWING SAFETY INFORMATION

### Gross Trailer Weight / GTW

The Gross Trailer Weight is the weight of the trailer & cargo. Measure this by putting the fully loaded trailer on a vehicle scale.



### Tongue Weight / TW

The downward force that is exerted on the hitch ball by the coupler. The tongue weight will vary depending on where the load is positioned in relationship to the trailer axle(s). To measure the tongue weight, use either a commercial scale or a bathroom scale with the coupler at towing height. When using a bathroom scale with heavier tongue weights, use the method shown and multiply the scale reading by 3.

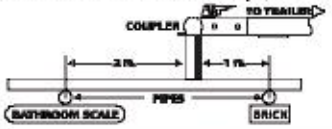

### Weight Carrying / WC

The total weight of both the trailer and the cargo inside. Never exceed the weight capacity of your trailer hitch.

### Weight Distribution / WD

Used to balance the weight of the cargo between the front and rear wheels throughout the trailer, allowing for better steering, braking, and level riding.



### Sway Control

A device used to reduce the lateral movements of the trailer that are caused by the wind. This works in conjunction with a weight distribution hitch. Do not use this on a class 1 or 2 hitch, or with surge brakes.

### How Much Can You Safely Tow?

TONGUE WEIGHT (lb)	1000	2000	3000	4000	5000	6000	7000	8000	10,000	12,000
Tongue weight should be about 10% to 15% percent of the gross trailer weight.										
CLASS 1										
CLASS 2										
CLASS 3										
CLASS 4										
CLASS 5										
TRAILER TYPE										
Coupler	1 1/2"	1 3/4"	1 3/4"	1 3/4"	1 3/4"	1 3/4"				
	1100	1200	1300	1400	1500	1600				
W/ coupler	1 1/2"	1 3/4"	1 3/4"	1 3/4"	1 3/4"	1 3/4"	1 3/4"	1 3/4"	1 3/4"	1 3/4"
	2100	2400	2700	3000	3300	3600	3900	4200	4500	4800
W/ coupler	1 1/2"	1 3/4"	1 3/4"	1 3/4"	1 3/4"	1 3/4"	1 3/4"	1 3/4"	1 3/4"	1 3/4"
	2800	3200	3600	4000	4400	4800	5200	5600	6000	6400
3/4" Wheel										

*Refer to owner's manual for towing capabilities and limitations.*

### Ball Mount

The ball mount is placed inside the opening of the receiver hitch which is mounted to the vehicle. Make sure a hitch pin and clip is properly securing the ball mount to the receiver hitch before you begin towing.

• A: Rise. B: Drop. C: Hole Size. D: Length.

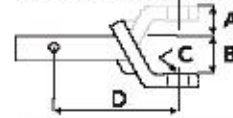

### Trailer Ball

The connection from the hitch to the trailer. There are many factors that determine the correct hitch ball:

- Number one is the hitch ball's gross trailer weight rating.
- The mounting platform must be at least 3/8" thick.
- The hole diameter must not be more than 1/16" larger than the threaded shank.
- Every time you tow, check the nut and lock washer to make sure they are fastened securely.

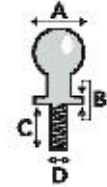

• A: Ball Dia. B: Shank Dia. C: Shank Length. D: Shank Rise.

### Coupler

The component that is placed over the trailer ball to connect the vehicle to the trailer. Be sure that the coupler size matches the size of the hitch ball and that the coupler handle is securely fastened. To determine what size hitch ball you need for your application you will need to know the size of coupler that is on the trailer. Be sure your coupler is properly adjusted to the ball you are using.

NOTE: For added security the use of safety devices such as Coupler Safety Pins and Locks is strongly recommended.

### Safety Chains

Safety chains are a requirement and should be crossed under the tongue of the trailer so that the tongue will not drop to the road if it becomes separated from the hitch. Always leave enough slack so you can turn. Never allow the safety chains to drag on the ground and never attach the chains to the bumper.

Trailer Classification: Safety Chain Breaking Force - Minimum

Class 1: 2,000 lbs. (8.9 kN)

Class 2: 3,500 lbs. (15.6 kN)

Class 3: 5,000 lbs. (22.2 kN)

The strength rating of each length of safety chain or its equivalent and its attachments shall be equal to or exceed in minimum breaking force the GVWR (Gross Vehicle Weight Rating) of the trailer.

### Electrical

Trailer lights, Electric Brakes, Break-away systems - Every time you tow, be sure to check that all components are working properly.

Wiring identification by color:



11454

MERCEDES-BENZ E300

GROSS LOAD CAPACITY WHEN USED AS A WEIGHT CARRYING HITCH: 2,000 LBS. TRAILER WEIGHT & 200 LBS. TONGUE WEIGHT.



WARNING: ALL NON-TRAILER LOADS APPLIED TO THIS PRODUCT MUST BE SUPPORTED BY 18050 STABILIZING STRAPS.  
**WARNING: \*\* FAILURE TO PROPERLY SUPPORT NON-TRAILER LOADS WILL VOID PRODUCT WARRANTY \*\***  
**WARNING: \*\*\* DO NOT EXCEED VEHICLE MANUFACTURER'S RECOMMENDED TOWING CAPACITY \*\*\***



Parts List			
ITEM	QTY	PART NUMBER	DESCRIPTION
1	4	7/16-14 x 1 1/4	CARRIAGE BOLT
2	4	CM-SP2	.250 x .88 x 2.25" SQUARE HOLE SPACER
3	4	7/16-14	HEX FLANGE NUT
4	4	7_16 FISHWIRE	7/16" FISHWIRE

TOOLS REQUIRED
RATCHET
TORQUE WRENCH
6" SOCKET EXTENSION
E12, 8mm, 10mm, 11/16" SOCKET
T25, T40 TORXBITS
DRILL
1/2" DRILL BIT
DIE GRINDER
AVIATION SHEARS
MASKING TAPE
MARKER
SAFETY GLASSES

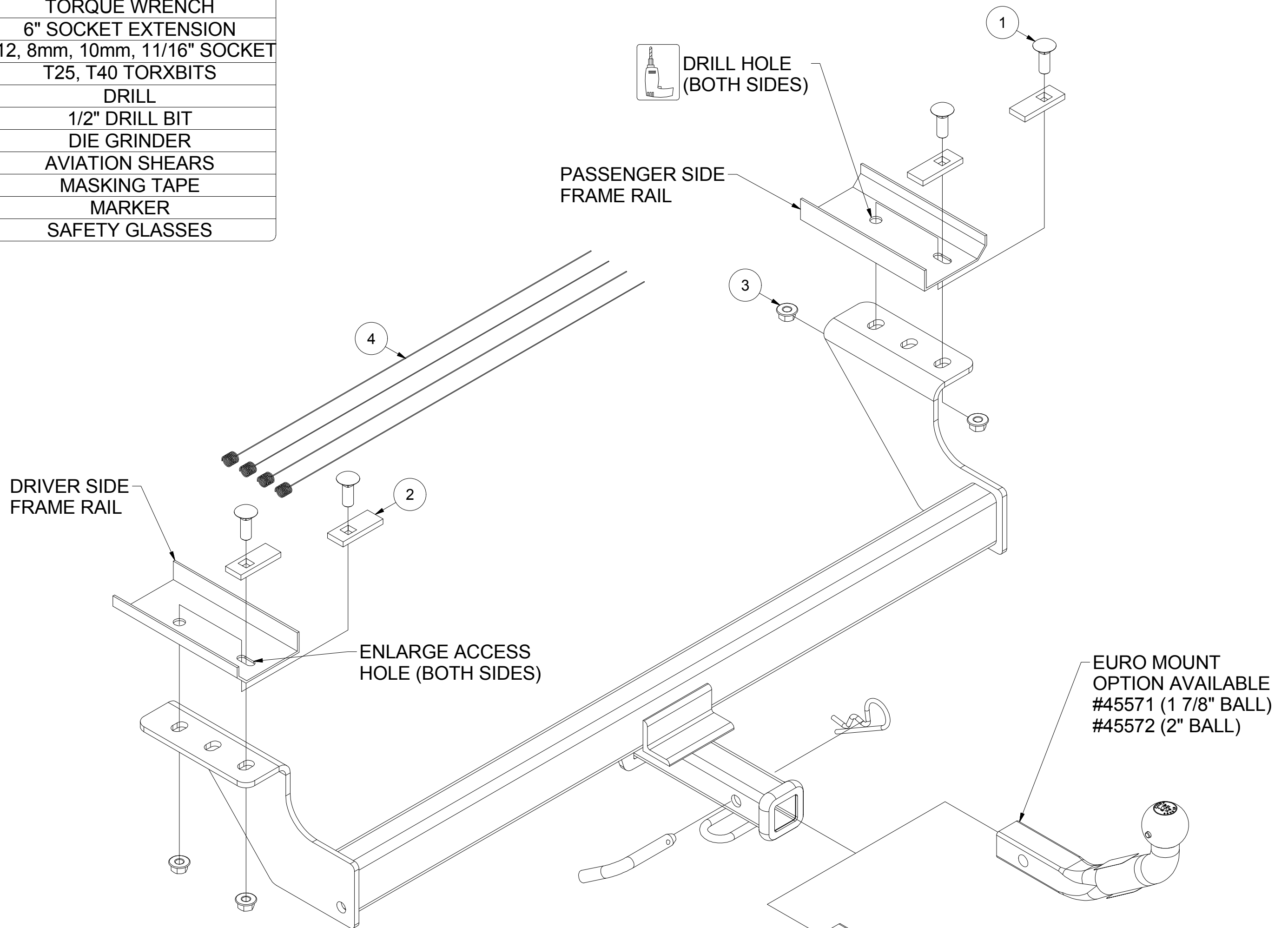

HITCH WEIGHT: 24 LBS.  
 INSTALL TIME  
 PROFESSIONAL: 45 MINUTES  
 NOVICE (DIY): 90 MINUTES  
 INSTALL NOTES:  
 -LOWER EXHAUST  
 -TEMPORARILY REMOVE EXHAUST TIPS AND HEAT SHIELDS  
 -TRIM REQUIRED  
 -DRILLING REQUIRED  
 -HOLE ENLARGEMENT REQUIRED

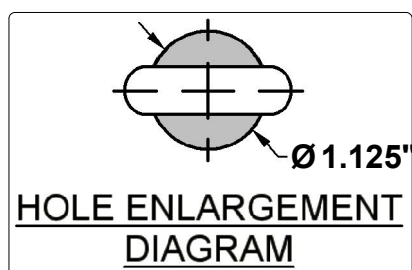

DESIGNED FOR USE WITH BALLMOUNT #45521

FRONT  
 REAR

**PERIODICALLY CHECK THIS RECEIVER HITCH TO ENSURE THAT ALL FASTENERS ARE TIGHT AND THAT ALL STRUCTURAL COMPONENTS ARE SOUND.**

CURT Manufacturing LLC., warrants this product to be free of defects in material and/or workmanship at the time of retail purchase by the original purchaser. If the product is found to be defective, CURT Manufacturing LLC., may repair or replace the product, at their option, when the product is returned, prepaid, with proof of purchase. Alteration to, misuse of, or improper installation of this product voids the warranty. CURT Manufacturing LLC.'s liability is limited to repair or replacement of products found to be defective, and specifically excludes liability for incidental or consequential loss or damage.



**11454****MERCEDES-BENZ****FISHWIRE TECHNIQUE**

INSERT COILED END OF FISHWIRE TOOL THROUGH HITCH MOUNTING HOLE IN VEHICLE FRAME RAIL AND OUT THE ACCESS HOLE. PASS COILED END OF FISHWIRE THROUGH SPACER AND THREAD BOLT INTO COIL. KINK WIRE TO KEEP SPACER SEPARATE FROM BOLT AS SHOWN. PULL FISHWIRE, SPACER, AND BOLT THROUGH FRAME AND OUT MOUNTING HOLE. USE FISHWIRE TO GUIDE HITCH DURING MOUNTING AND PREVENT LOSS OF BOLT / SPACER INSIDE FRAME RAIL.

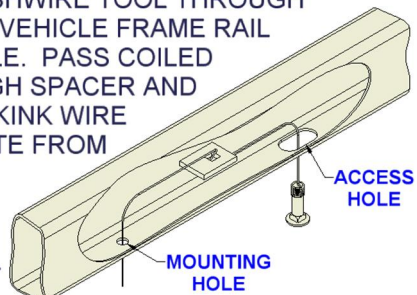

**\*\*NOTE: SOME VEHICLES MAY FISHWIRE THROUGH END OF FRAME\*\***

**REVERSE PULL FISHWIRE TECHNIQUE**

ATTACH FISHWIRE TO CARRIAGE BOLT AND SLIDE SPACER ONTO FISHWIRE. PUSH THE BOLT THRU THE HOLE FOLLOWED BY THE SPACER (AS SHOWN). PULL BOLT BACK INTO POSITION, PROTRUDING FROM THE FRAME.

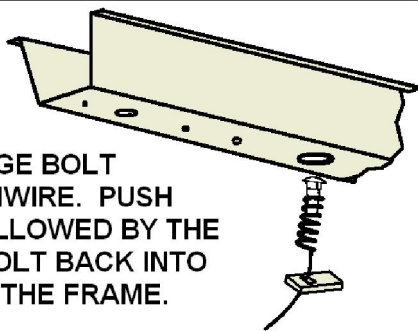
**RUBBER ISOLATOR REMOVAL DIAGRAM**

This technique can be used if an Exhaust Hanger Removal Pliers is not available.

Using a 5/8" open end wrench, slide the wrench up to the rubber isolator, cradling the hanger rod as shown. Next place the flat edge of a pry bar between the wrench and the hanger stop or hanger rod. Then simply rotate the pry bar toward the wrench to remove the rubber isolator.

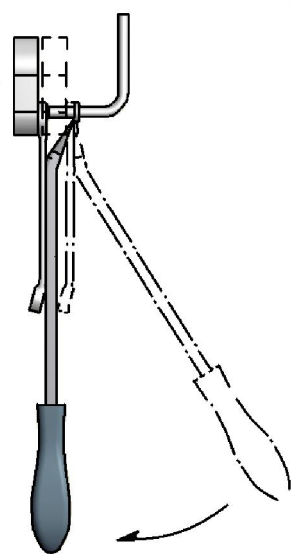

**Note:** Using a spray lubricant or soapy water on the hanger rod and the rubber isolator helps removal.

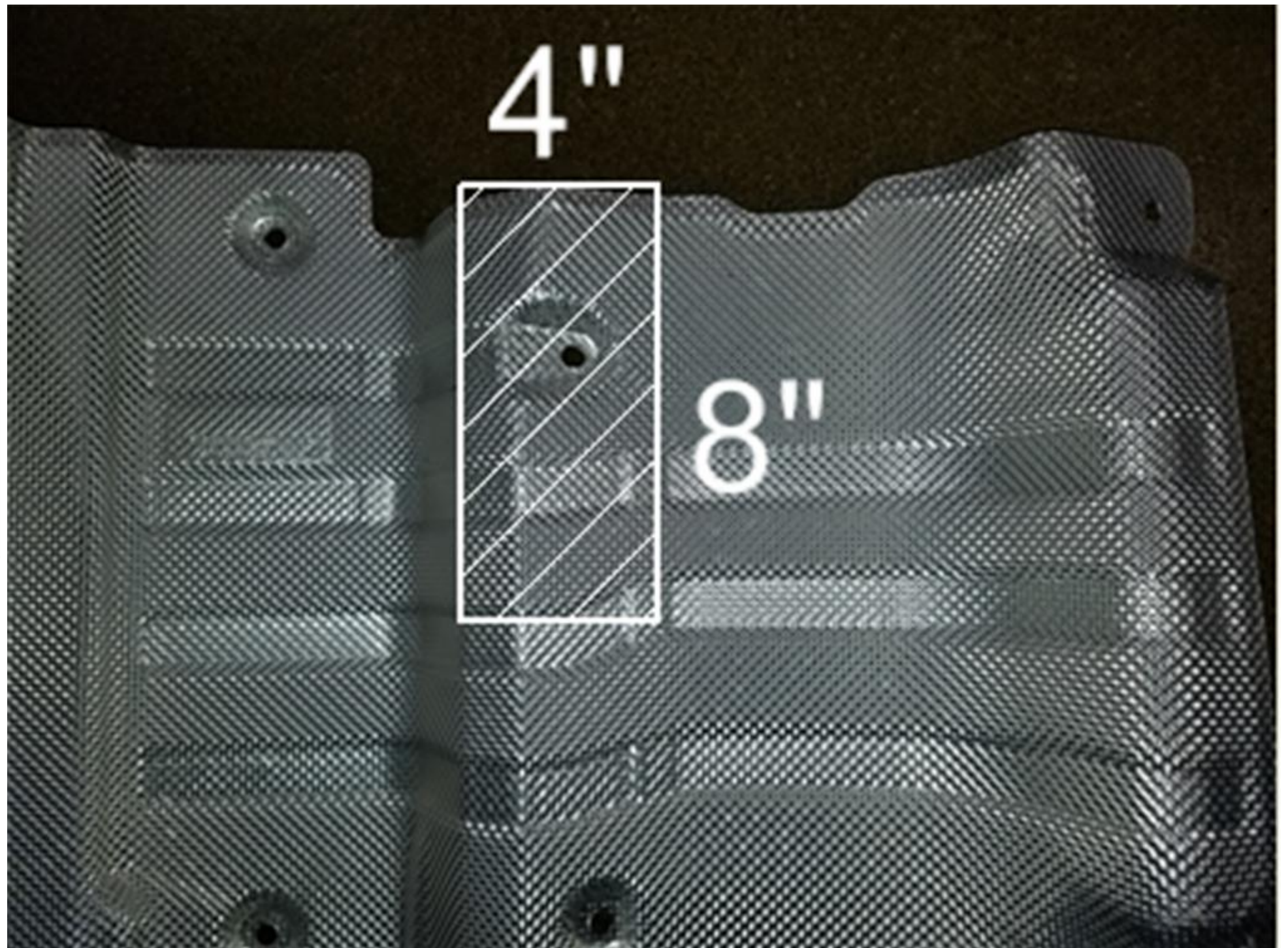
**INSTALLATION STEPS**

1. Locate on the exhaust tips (6) bolts, (3) on each tip, and remove using a T40 torxbit socket. Remove exhaust tips and set aside for later reinstallation.
2. To lower exhaust, remove (2) bolts using an E12 socket from the exhaust bracket on each side. Locate and remove (2) rubber isolators from the exhaust towards the front of the vehicle.
3. On the heat shields, locate and remove (4) nuts using an 8mm socket, (2) bolts using a 10mm socket, (2) screws using a T25 torxbit socket, and (1) metal clip from the heat shield on each side. Set aside for later reinstallation.
4. On the heat shields mark out a 4" x 8" section using masking tape and trim out using aviation shears. Reinstall heat shields using hardware from Step 3.
5. Raise hitch into position aligning the rear-most hole of the hitch with the existing hole on the frame to use as a template to mark out the forward most hole on each side of the hitch. Lower hitch and drill out the marked areas using a 1/2" drill bit.  
**NOTE:** for ease of drilling push the exhaust towards the side of the vehicle.
6. Use the die grinder to enlarge the slotted hole to a 1.125" hole. Verify that provided bolt head will fit through hole before moving on to next step.
7. Fishwire (1) 7/16" carriage bolt and (1) CM-SP2 spacer through the enlarged access hole to the forward most hole in the frame on each side. Reverse fishwire (1) 7/16" carriage bolt and (1) CM-SP2 spacer through the enlarged access hole on each frame rail.
8. Raise hitch into position feeding the fishwires through the holes in the hitch. Once hitch is in place, remove fishwires and loosely fasten (2) 7/16" hex flange nuts on each side.
9. Torque all 7/16" hardware to 59 ft-lbs. Reinstall exhaust tips and raise exhaust following Step 1-2 in reverse order.

**PERIODICALLY CHECK THIS RECEIVER HITCH TO ENSURE THAT ALL FASTENERS ARE TIGHT AND THAT ALL STRUCTURAL COMPONENTS ARE SOUND.**

CURT Manufacturing LLC., warrants this product to be free of defects in material and/or workmanship at the time of retail purchase by the original purchaser. If the product is found to be defective, CURT Manufacturing LLC., may repair or replace the product, at their option, when the product is returned, prepaid, with proof of purchase. Alteration to, misuse of, or improper installation of this product voids the warranty. CURT Manufacturing LLC.'s liability is limited to repair or replacement of products found to be defective, and specifically excludes liability for incidental or consequential loss or damage.