

YEARS: 2016 - PRESENT

MAKE: CHEVROLET

MODEL: VOLT

STYLE: SEDAN

WARNING: NEVER EXCEED YOUR VEHICLE MANUFACTURER'S RECOMMENDED TOWING CAPACITY

WEIGHT CARRYING:
 TRAILER WEIGHT: 1000 LBS.
 TONGUE WEIGHT: 100 LBS.

PRO INSTALL TIME: 30 MIN.
NOVICE INSTALL TIME: 60 MIN.

IF YOU ARE HESITANT TO UNDERTAKE THIS TASK ON YOUR OWN, CONTACT AN AUTHORIZED CURT INSTALLER FOR ADDITIONAL ASSISTANCE.

INSTALLATION REQUIRES:

RATCHET	TORQUE WRENCH	6" SOCKET EXTENSION
7mm 10mm 13mm 15mm SOCKET	T15 TORXBIT SOCKET	SCREW DRIVER
MASKING TAPE	AVIATION SHEARS	SAFETY GLASSES

INSTALLATION TIPS:

- BEFORE YOU BEGIN INSTALLATION, READ ALL INSTRUCTIONS THOROUGHLY.
- TO EASE INSTALLATION, 2 PEOPLE MAY BE REQUIRED.
- USING PROPER TOOLS WILL GREATLY IMPROVE THE QUALITY OF THE INSTALL AND REDUCE THE TIME REQUIRED.

LEVEL OF DIFFICULTY: MODERATE

EASY	MODERATE	CHALLENGING
	TEMPORARILY REMOVE PART (UNDERBODY PANEL & BUMPER FASCIA)	
	TEMPORARILY LOWER EXHAUST	
	TRIMMING REQUIRED	
	NO DRILLING REQUIRED	

VEHICLE PHOTO:



REPRESENTATIVE PHOTO

HITCH ILLUSTRATION:

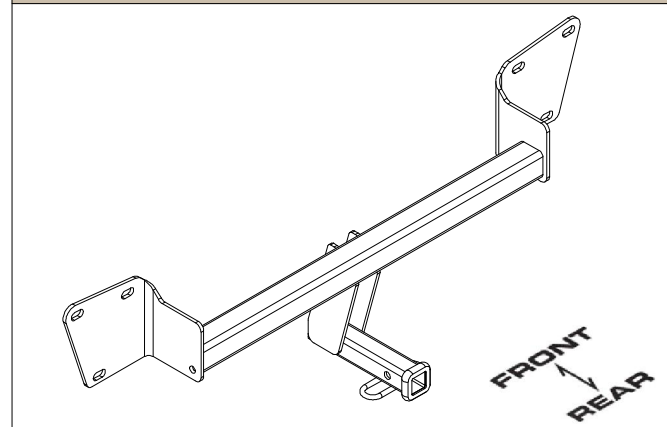

MAKE SURE YOUR HITCH MATCHES

INSTALLATION WALKTHROUGH:

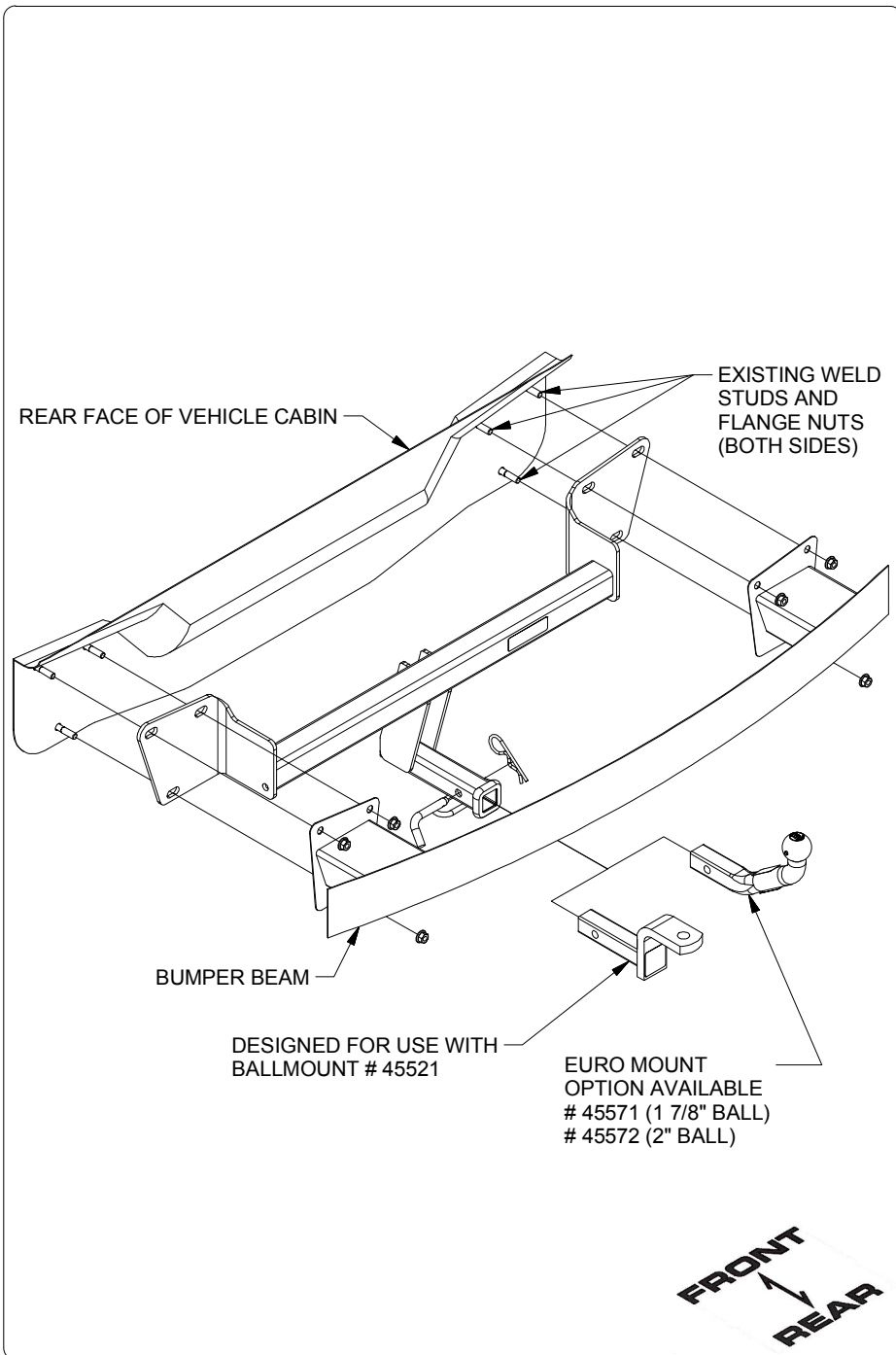

1. On underbody panel, locate and remove (8) screws using a 7mm socket, (7) plastic nuts using a 10mm socket, (3) torx screws using a T15 torx bit, and (1) plastic push pin using a screwdriver. Remove underbody panel and mark out a 2.5" x 4.5" section using tape, then, trim using aviation shears. Set underbody panel aside for reinstallation.

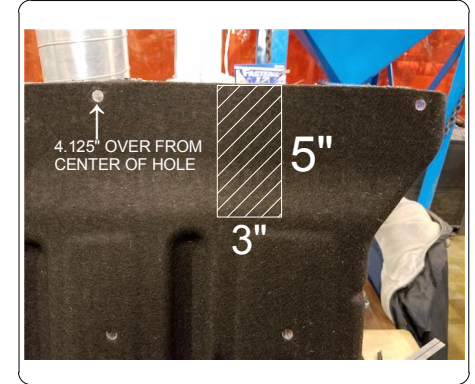
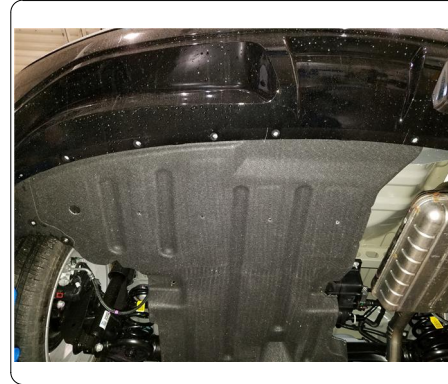

2. Locate and remove (13) torx screws, (4) in each wheel well, (2) on Driver Side at the bottom of the wheel well, and (3) on Passenger Side at bottom of wheel well using a T15 torx bit. Pull wheel well back to reveal a screw. Remove screw using a 7mm socket.

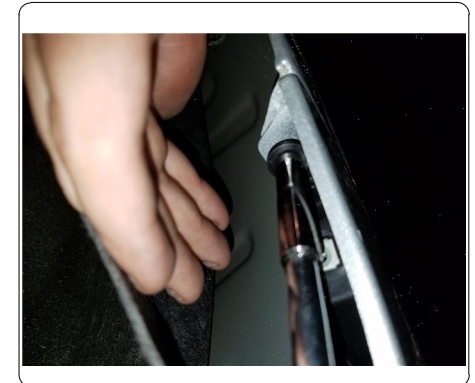
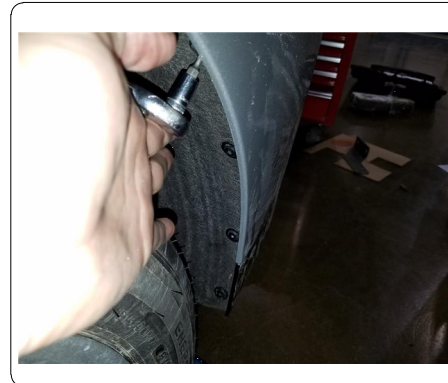

INSTALLATION WALKTHROUGH:

3. Open trunk and remove (1) screw using a screwdriver, and (2) bolts using a 10mm socket from each tail light. Grab and gently pull light towards rear of car for removal. Unplug the tail lights from the car and set aside for reinstallation.

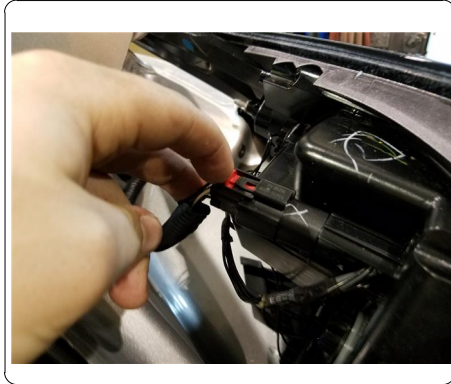
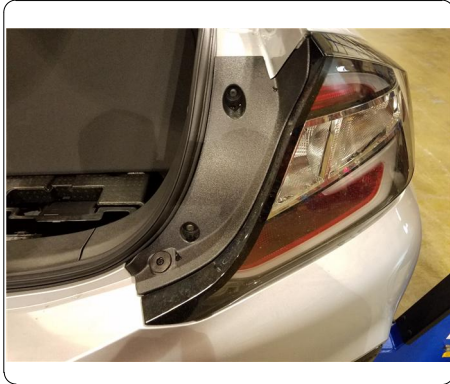

4. To remove bumper fascia, start at the sides, gently pulling the fascia out and work towards the rear of the vehicle. Once unhooked from the car, locate and unplug the electrical from the bumper fascia. Set aside for reinstallation.

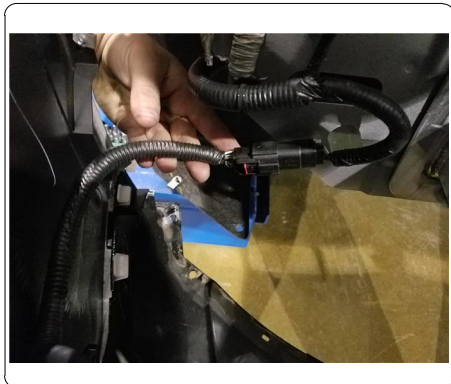
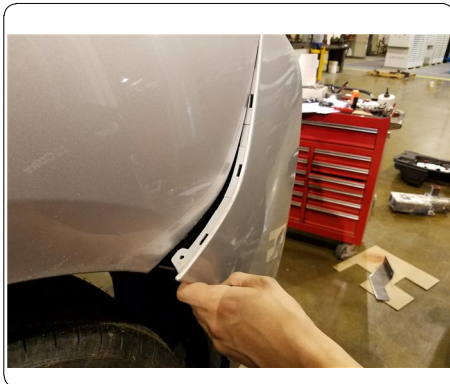

5. Locate and remove (6) M10 nuts, (3) on each side, using a 15mm socket from the bumper beam. On the passenger side, locate the exhaust bracket and remove (2) M8 bolts using a 13mm socket. Lift exhaust bracket up and over the clips to remove bumper beam. Set aside for reinstallation.

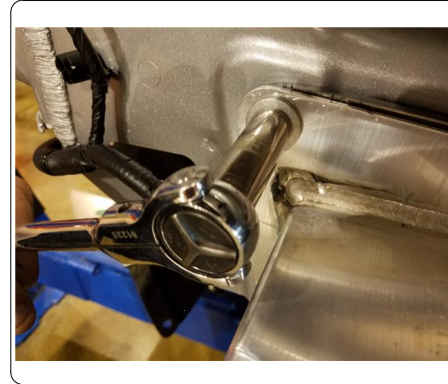

6. Raise hitch into position, centering on vehicle. Raise bumper beam back into position over the hitch and loosely fasten (6) M10 nuts removed in STEP 5. Raise exhaust bracket back into position and loosely fasten (2) M8 bolts removed from STEP 5.

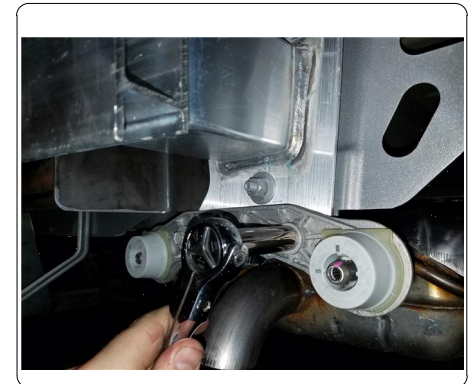

INSTALLATION WALKTHROUGH:

7. Torque all M10 hardware to 45.2 ft.-lbs. Torque all M8 hardware to 22.9 ft.-lbs. Reinstall following steps 1-4 in reverse order.



TOWING SAFETY INFORMATION

Gross Trailer Weight / GTW

The Gross Trailer Weight is the weight of the trailer & cargo. Measure this by putting the fully loaded trailer on a vehicle scale.



Tongue Weight / TW

The downward force that is exerted on the hitch ball by the coupler. The tongue weight will vary depending on where the load is positioned in relationship to the trailer axle(s). To measure the tongue weight, use either a commercial scale or a bathroom scale with the coupler at towing height. When using a bathroom scale with heavier tongue weights, use the method shown and multiply the scale reading by 3.

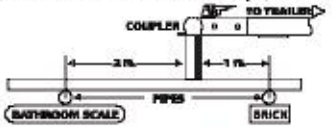

Weight Carrying / WC

The total weight of both the trailer and the cargo inside. Never exceed the weight capacity of your trailer hitch.

Weight Distribution / WD

Used to balance the weight of the cargo between the front and rear wheels throughout the trailer, allowing for better steering, braking, and level riding.



Sway Control

A device used to reduce the lateral movements of the trailer that are caused by the wind. This works in conjunction with a weight distribution hitch. Do not use this on a class 1 or 2 hitch, or with surge brakes.

How Much Can You Safely Tow?

TONGUE WEIGHT (lb)	1000	2000	3000	4000	5000	6000	7000	8000	10,000	12,000
Tongue weight should be about 10% to 15% percent of the gross trailer weight.										
CLASS 1										
CLASS 2										
CLASS 3										
CLASS 4										
CLASS 5										
TRAILER TYPE	CLASS 1	CLASS 2	CLASS 3	CLASS 4	CLASS 5					
Coupler	1 1/2"	1 3/4"	1 3/4"	1 3/4"	1 3/4"	1 3/4"				
1/2" Hitch	1100	1200	1300	1400	1500	1600				
Weighted Hitch	1 1/2"	1 3/4"	1 3/4"	1 3/4"	1 3/4"	1 3/4"	2 1/2"	3 1/2"	3 1/2"	3 1/2"
1/2" Hitch	2100	2400	2700	3000	3300	3600	3900	4200	4500	4800
Weighted Hitch	1 1/2"	1 3/4"	1 3/4"	1 3/4"	1 3/4"	1 3/4"	2 1/2"	3 1/2"	3 1/2"	3 1/2"
3/4" Hitch	2800	3200	3600	4000	4400	4800	5200	5600	6000	6400
3/4" Hitch										

Refer to owner's manual for towing capabilities and limitations.

Ball Mount

The ball mount is placed inside the opening of the receiver hitch which is mounted to the vehicle. Make sure a hitch pin and clip is properly securing the ball mount to the receiver hitch before you begin towing.

• A: Rise. B: Drop. C: Hole Size. D: Length.

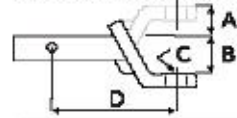

Trailer Ball

The connection from the hitch to the trailer. There are many factors that determine the correct hitch ball:

- Number one is the hitch ball's gross trailer weight rating.
- The mounting platform must be at least 3/8" thick.
- The hole diameter must not be more than 1/16" larger than the threaded shank.
- Every time you tow, check the nut and lock washer to make sure they are fastened securely.

• A: Ball Dia. B: Shank Dia. C: Shank Length. D: Shank Rise.

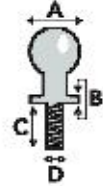

Coupler

The component that is placed over the trailer ball to connect the vehicle to the trailer. Be sure that the coupler size matches the size of the hitch ball and that the coupler handle is securely fastened. To determine what size hitch ball you need for your application you will need to know the size of coupler that is on the trailer. Be sure your coupler is properly adjusted to the ball you are using.

NOTE: For added security the use of safety devices such as Coupler Safety Pins and Locks is strongly recommended.

Safety Chains

Safety chains are a requirement and should be crossed under the tongue of the trailer so that the tongue will not drop to the road if it becomes separated from the hitch. Always leave enough slack so you can turn. Never allow the safety chains to drag on the ground and never attach the chains to the bumper.

Trailer Classification: Safety Chain Breaking Force - Minimum

Class 1: 2,000 lbs. (8.9 kN)

Class 2: 3,500 lbs. (15.6 kN)

Class 3: 5,000 lbs. (22.2 kN)

The strength rating of each length of safety chain or its equivalent and its attachments shall be equal to or exceed in minimum breaking force the GVWR (Gross Vehicle Weight Rating) of the trailer.

Electrical

Trailer lights, Electric Brakes, Break-away systems - Every time you tow, be sure to check that all components are working properly.

Wiring identification by color:



11436

CHEVROLET VOLT

4/13/2016

GROSS LOAD CAPACITY WHEN USED AS A WEIGHT CARRYING HITCH: 1000 LBS. TRAILER WEIGHT & 100 LBS. TONGUE WEIGHT.

WARNING: ALL NON-TRAILER LOADS APPLIED TO THIS PRODUCT MUST BE SUPPORTED BY 18050 STABILIZING STRAPS.



WARNING: ** FAILURE TO PROPERLY SUPPORT NON-TRAILER LOADS WILL VOID PRODUCT WARRANTY **

WARNING: * DO NOT EXCEED VEHICLE MANUFACTURER'S RECOMMENDED TOWING CAPACITY**



TOOLS REQUIRED
RATCHET
6" SOCKET EXTENSION
7mm, 10mm, 13mm, 15mm SOCKET
T15 TORXBIT SOCKET
SCREWDRIVER
TORQUE WRENCH
MASKING TAPE
AVIATION SHEARS
SAFETY GLASSES

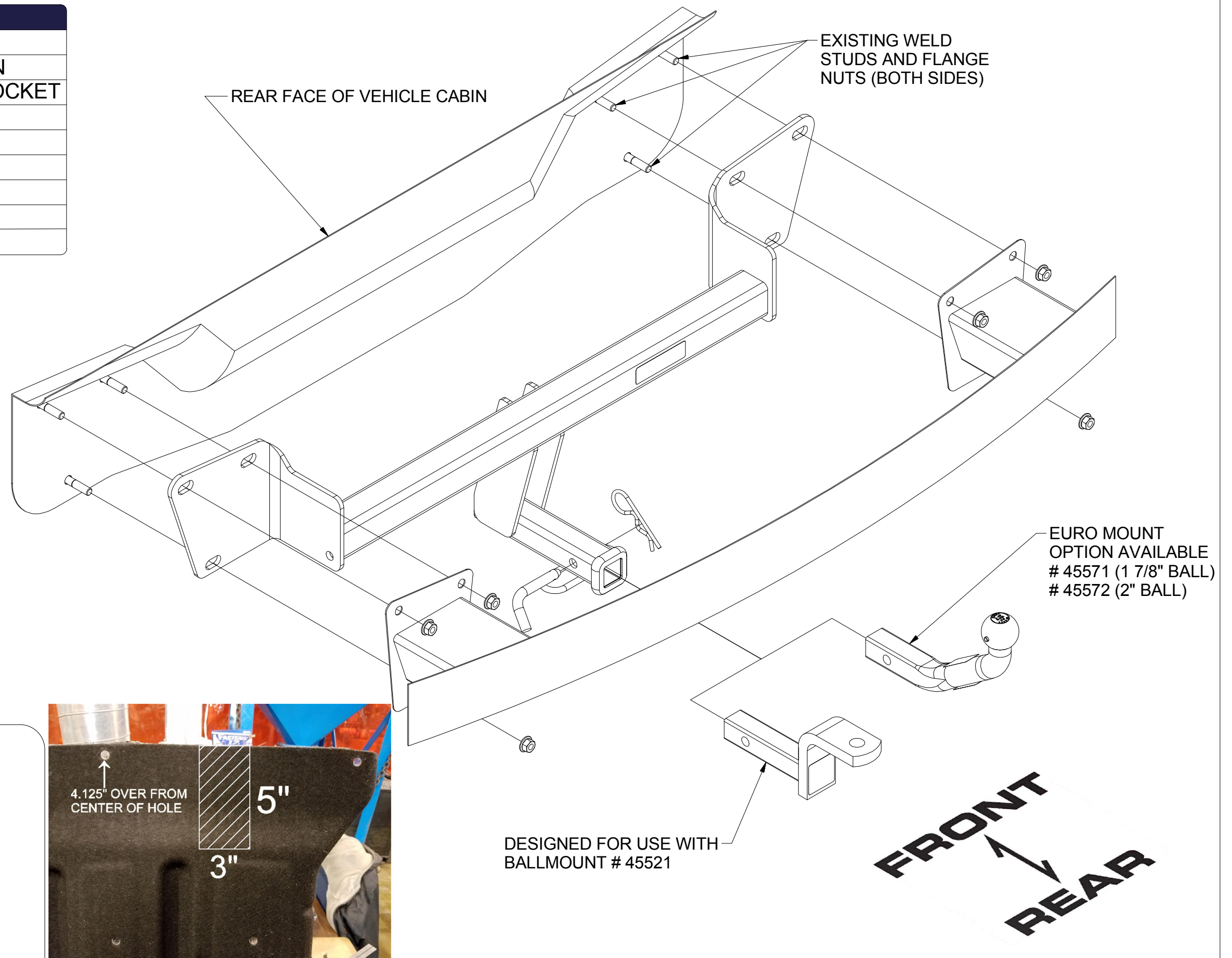

HITCH WEIGHT: 26 LBS.

INSTALL TIME

PROFESSIONAL: 30 MINUTES

NOVICE (DIY): 60 MINUTES

INSTALL NOTES:

- TEMPORARY PART REMOVAL
- LOWER EXHAUST
- TRIMMING REQUIRED
- NO DRILLING REQUIRED

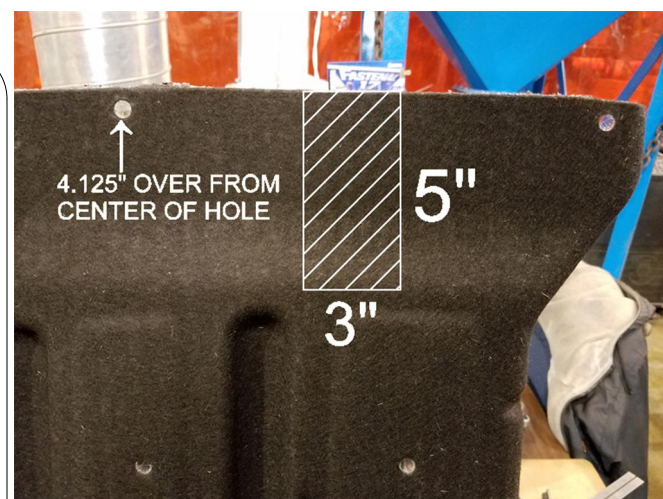

INSTALLATION STEPS

1. On underbody panel, locate and remove (8) screws using a 7mm socket, (7) plastic nuts using a 10mm socket, (3) torx screws using a T15 torx bit, and (1) plastic push pin using a screwdriver. Remove underbody panel and mark out a 2.5" x 4.5" section using tape, then, trim using aviation shears. Set underbody panel aside for reinstallation.
2. Locate and remove (8) torx screws, (4) in each wheel well, (2) on Driver Side at the bottom of the wheel well, and (3) on Passenger Side at bottom of wheel well using a T15 torx bit. Pull wheel well back to reveal a screw. Remove screw using a 7mm socket.
3. Open trunk and remove (1) screw using a screwdriver, and (2) bolts using a 10mm socket from each tail light. Grab and gently pull light towards rear of car for removal. Unplug the tail lights from the car and set aside for reinstallation.
4. To remove bumper fascia, start at the sides, gently pulling the fascia out and work towards the rear of the vehicle. Once unhooked from the car, locate and unplug the electrical from the bumper fascia. Set aside for reinstallation.
5. Locate and remove (6) M10 nuts, (3) on each side, using a 15mm socket from the bumper beam. On the passenger side, locate the exhaust bracket and remove (2) M8 bolts using a 13mm socket. Lift exhaust bracket up and over the clips to remove bumper beam. Set aside for reinstallation.
6. Raise hitch into position, centering on vehicle. Raise bumper beam back into position over the hitch and loosely fasten (6) M10 nuts removed in STEP 5. Raise exhaust bracket back into position and loosely fasten (2) M8 bolts removed from STEP 5.
7. Torque all M10 hardware to 45.2 ft-lbs. Torque all M8 hardware to 22.9 ft-lbs. Reinstall following steps 1-4 in reverse order.

PERIODICALLY CHECK THIS RECEIVER HITCH TO ENSURE THAT ALL FASTENERS ARE TIGHT AND THAT ALL STRUCTURAL COMPONENTS ARE SOUND.