

INSTALLATION INSTRUCTIONS

DO NOT EXCEED PRODUCT RATING OR TOW VEHICLE'S LAMP LOAD RATING, WHICHEVER IS LOWER

55151 CONVERTER WIRING KIT



TOOLS NEEDED

- Crimping tool
- Wire stripper
- Phillips screwdriver

WARNING

The battery connection must be fuse protected, 10 amp max. Exceeding the product rating can cause loss of warranty, overheating and potential fire. Do not exceed product rating or tow vehicle's lamp load rating, whichever is lower.

CONVERTER WIRING DIAGRAM

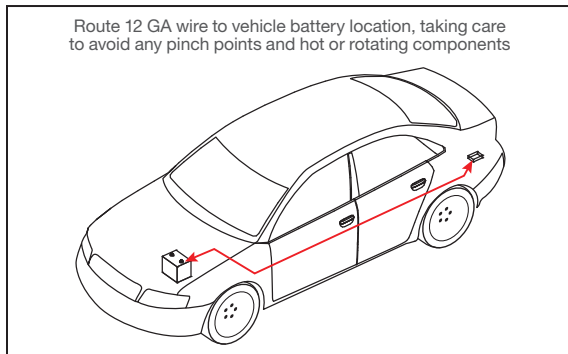
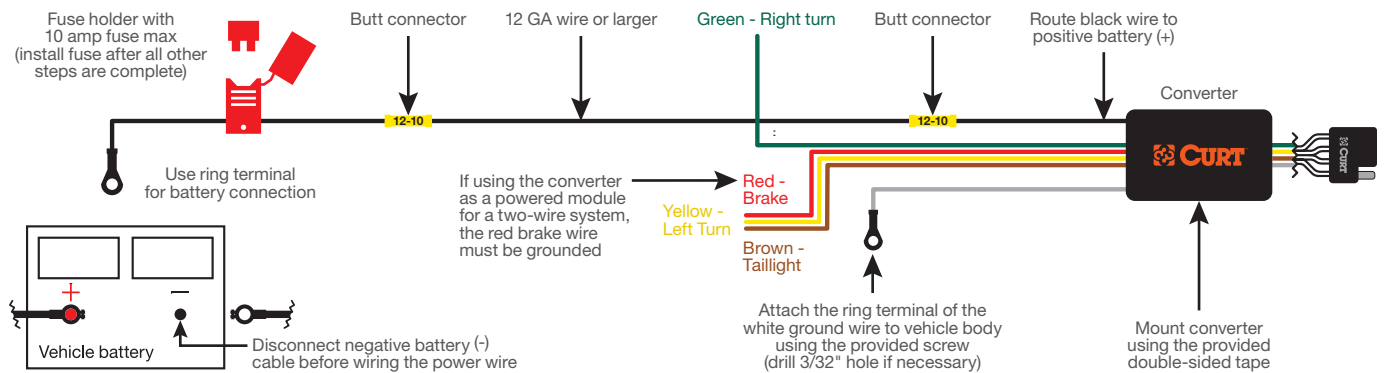

Warning:

To avoid personal injury or property damage, check for miscellaneous items that may be behind or under any surface before drilling.

Notes:

1. This converter system is to be used only on 12 volt negative ground systems.
2. Secure power wire to vehicle chassis using cable ties provided.
3. When passing the power wire through sheet metal, use an existing grommet, add a grommet or use silicone to protect the power wire from sharp edges.
4. Overall wiring harness design may differ from illustration. The illustration should be used for power lead instruction only. Illustration is not to scale.

Attention: Illustrations are for reference only. Battery location may differ depending on the vehicle.