

****DO NOT EXCEED RECOMMENDED VEHICLE TOWING WEIGHT!****

60661 SUBKIT

DODGE 2500 / 3500 SHORT AND LONG BED

9/27/2013

PAGE 1 OF 4

WARNING!! BRAKE, FUEL, AND ELECTRICAL LINES MAY NEED TO BE LOOSENED OR REPOSITIONED TO PROVIDE CLEARANCE FOR NEW HARDWARE. SOME MODELS MAY REQUIRE MODIFICATION OR REMOVAL OF HEAT SHIELDS. ON SHORT BED MODELS, CHECK FOR ADEQUATE TURNING CLEARANCE BETWEEN THE FRONT OF ALL TRAILERS AND THE TRUCK CAB. ON TWO WHEEL DRIVE TRUCKS A CLEARANCE CHECK MUST BE PERFORMED WHEN TRUCK IS LOADED AND UNLOADED TO VERIFY THE INVERTED BALL WILL NOT INTERFERE WITH THE TOP OF THE DIFFERENTIAL

Bolt Kit			
ITEM	QTY	PART NUMBER	DESCRIPTION
1	4	1/2-13 x 1, GR8	CARRIAGE BOLT
2	12	1/2-13 x 1 1/2, GR8	CARRIAGE BOLT
3	4	CM-SP3	.250 x 1.25 x 2.00" SQUARE HOLE SPACER
4	4	CM-SP12	.250 x 1.00 x 2.00" SQUARE HOLE SPACER
5	4	CM-1209-UBS	1/2-13 x 4 x 7.25 x 1 3/4 SQ U-BOLT
6	24	HFN 1213, GR8	HEX FLANGE NUT
7	4	M10 - 1.5 x 40mm	HEX BOLT
8	4	7/16"	CONICAL TOOTHED WASHER
9	4	M10 - 1.5 x 70 HEX	HEX BOLT

Parts List			
ITEM	QTY	PART NUMBER	DESCRIPTION
A	2	60661-CA	2.50 x 2.00 x .375" CROSS ARM
B	1	60661-DSWA	.250" DRIVER SIDE PLATE
C	1	60661-DSB	.250" DRIVER SIDE BRACKET
D	1	60661-PSWA	.250" PASSENGER SIDE PLATE
E	1	60661-PSB	.250" PASSENGER SIDE BRACKET
9	4	M10 - 1.5 x 70 HEX	HEX BOLT
F	2	60661-SP	.313" SPACER PLATE
G	1	CM-C655-EH	EXHAUST HANGER

- TOOLS REQUIRED**
- SAFETY GLASSES
 - RATCHET
 - 15mm, 17mm, & 3/4" SOCKETS
 - CRESCENT WRENCH
 - TORQUE WRENCH

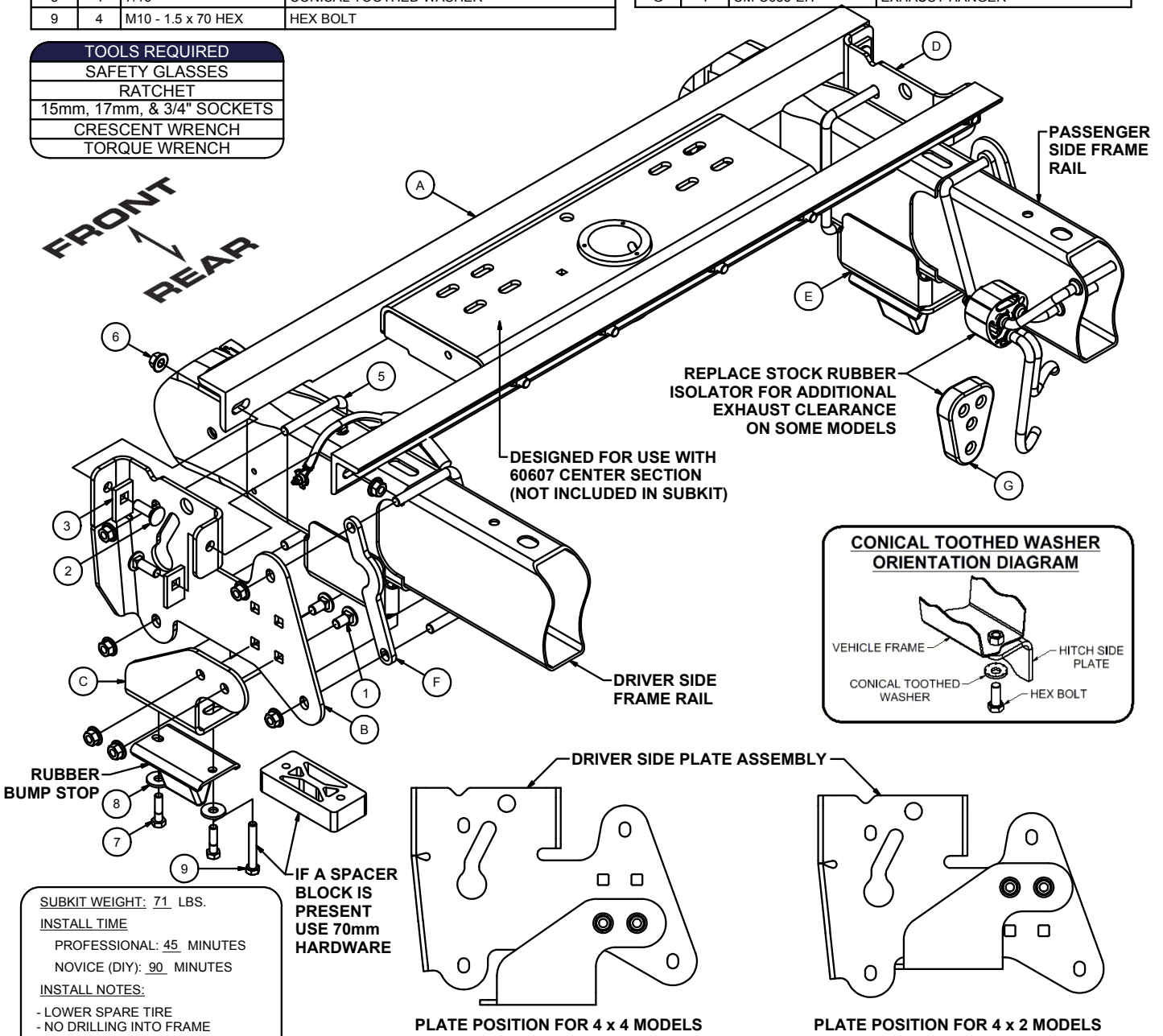

SUBKIT WEIGHT: 71 LBS.
 INSTALL TIME
 PROFESSIONAL: 45 MINUTES
 NOVICE (DIY): 90 MINUTES
 INSTALL NOTES:
 - LOWER SPARE TIRE
 - NO DRILLING INTO FRAME

PERIODICALLY CHECK THIS GOOSENECK HITCH TO ENSURE THAT ALL FASTENERS ARE TIGHT AND THAT ALL STRUCTURAL COMPONENTS ARE SOUND.

WARNING!! BRAKE, FUEL, AND ELECTRICAL LINES MAY NEED TO BE LOOSENED OR REPOSITIONED TO PROVIDE CLEARANCE FOR NEW HARDWARE. SOME MODELS MAY REQUIRE MODIFICATION OR REMOVAL OF HEAT SHIELDS. ON SHORT BED MODELS, CHECK FOR ADEQUATE TURNING CLEARANCE BETWEEN THE FRONT OF ALL TRAILERS AND THE TRUCK CAB. ON TWO WHEEL DRIVE TRUCKS A CLEARANCE CHECK MUST BE PERFORMED WHEN TRUCK IS LOADED AND UNLOADED TO VERIFY THE INVERTED BALL WILL NOT INTERFERE WITH THE TOP OF THE DIFFERENTIAL

INSTALLATION STEPS:

1. Mark the location for the hole in the truck bed. Measure from the tailgate end of the truck bed, by hooking a tape measure over the **rear of the truck box** and marking the correct location. (**NOTE: DO NOT MEASURE FROM EDGE OF THE TAILGATE**) Next, mark the center between the wheel wells. This marks the center point for the drill hole. This hole location is critical for the correct installation of this hitch. Measure, mark, and saw carefully. This location will put the ball approximately 3" in front of the axle.

Short Bed Installation = 42 1/2"

Long Bed Installation = 44 1/2"

NOTE: If the truck has a spray on bed liner, add approximately 1/8" when measuring the location of the center hole. If truck has a plastic bed liner, you may drill through both, but it is more difficult to accurately locate the midpoint between the wheel wells, and to keep the bed liner from moving while cutting the hole. Make a 4" hole at this location using a 4" hole saw.

2. Temporarily remove spare tire and temporarily remove plastic wheel well covers (if vehicle is equipped with them and if they are a style which prevents hitch installation).
3. Insert cross arm (A) by sliding it between the frame and the bottom of the truck bed. It needs to be inserted so the leg without the holes will be against the bottom of the bed and the leg with the holes will face the rear of the vehicle, see **FIGURE A**. **NOTE:** Use a crescent wrench to bend the metal flange below the bed outward to allow the cross arms to be slid into position. The cross arm can be used as a lever to add additional bend to the flange, if needed. Insert the cross arm in the location shown in **FIGURE A** until it spans the frame rails. Slide the cross arm forward so that it is next to the forward bed support.
4. Insert the second cross arm (A) in the same location that the first cross arm was inserted. Slide it in until it spans the frame rails. This needs to be inserted so the leg without the holes will be against the bottom of the bed and the leg with the holes will face the front of the vehicle, see **FIGURE A**.
5. Place the forward U-bolt (4) into position on the inside of the driver side frame rail. See **FIGURE B** for approximate location of the U-bolt. One or two of the wire harness clips may need to be unfastened from the inside of the driver side frame rail on some models for the U-bolt to be put into position. **NOTE: The U-bolts must be positioned under all the brake lines and wires, see FIGURE B.**
6. The rearmost rubber exhaust isolator may need to be replaced with the included isolator (G) on some models. Replace if needed for additional clearance between the exhaust and the hitch, see **PAGE 1**. This will only be needed on models with exhaust styles shown in **FIGURE C**.

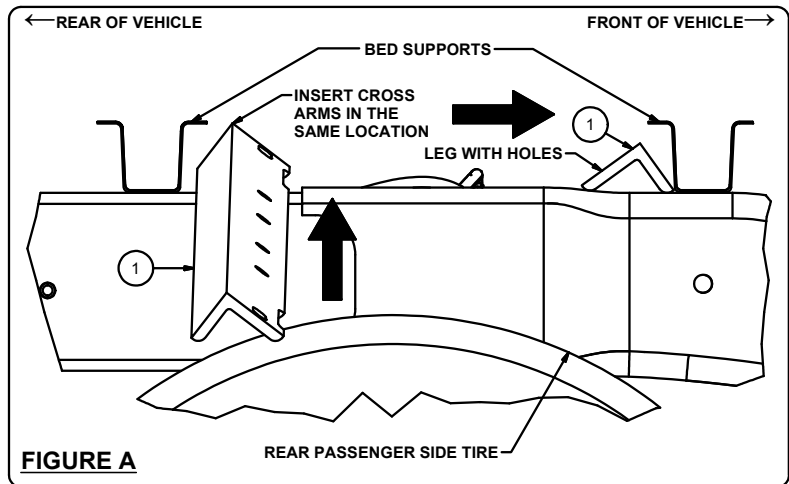

FIGURE A

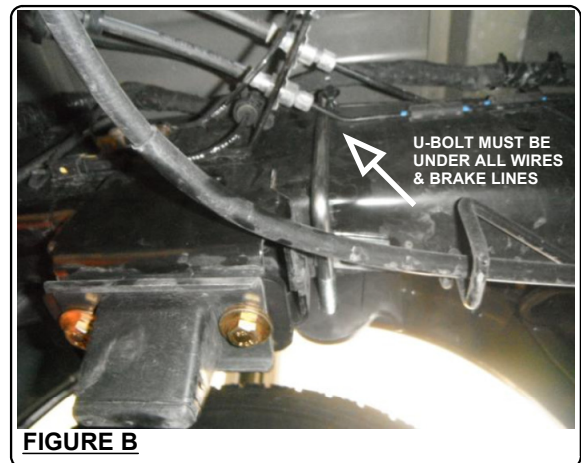

FIGURE B

PERIODICALLY CHECK THIS GOOSENECK HITCH TO ENSURE THAT ALL FASTENERS ARE TIGHT AND THAT ALL STRUCTURAL COMPONENTS ARE SOUND.

WARNING!! BRAKE, FUEL, AND ELECTRICAL LINES MAY NEED TO BE LOOSENED OR REPOSITIONED TO PROVIDE CLEARANCE FOR NEW HARDWARE. SOME MODELS MAY REQUIRE MODIFICATION OR REMOVAL OF HEAT SHIELDS. ON SHORT BED MODELS, CHECK FOR ADEQUATE TURNING CLEARANCE BETWEEN THE FRONT OF ALL TRAILERS AND THE TRUCK CAB. ON TWO WHEEL DRIVE TRUCKS A CLEARANCE CHECK MUST BE PERFORMED WHEN TRUCK IS LOADED AND UNLOADED TO VERIFY THE INVERTED BALL WILL NOT INTERFERE WITH THE TOP OF THE DIFFERENTIAL

INSTALLATION STEPS CONTINUED:

7. Raise the center section into position. **NOTE:** The gooseneck center cylinder will be offset towards the rear of the vehicle, see **PAGE 1**. Loosely attach to the forward cross arm by placing four 1/2" x 1 1/2" carriage bolts (2) with four CM-SP12 spacers (4) in through the forward cross arm and attach center section with four 1/2" hex flange nuts (6), see **FIGURE D**. Slide the rearward cross arm forward and loosely attach to the center section by inserting four 1/2" x 1 1/2" carriage bolts (2) in through the center and out the rearward cross arm. Attach with four 1/2" hex flange nuts (6), see **FIGURE D**.

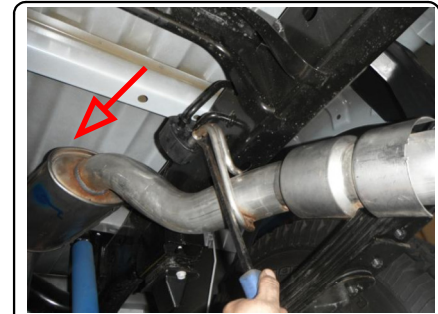

FIGURE C

8. Loosely assemble the side plates with brackets (B & C) and (D & E) using 1/2" x 1" carriage bolts (1) and 1/2" hex flange nuts (6). The brackets will attach to the top set of holes on the side plates for two wheel drive models and the bottom set of holes for four wheel drive models, see **PAGE 1**.

9. Remove the the rubber bump stop from underneath each frame rail by removing two M10 bolts from each. Save the rubber bump stops for reinstallation but the hardware removed will not be reinstalled.

10. Place driver side plate assembly over the U-bolt (5) which was positioned in step 5. Attach to the U-bolt with two 1/2" hex flange nuts (6). **NOTE:** The ground wire on the outside of the driver side frame rail on 2012 and earlier models must not be pinched between the driver side plate (B) and frame. This ground wire may need to be loosened, rotated slightly and retightened for the plate to be put into position.

11. Insert the rearward U-bolt (5) over the inside of the driver side frame rail and position the spacer (F) between the plate and frame rail in the orientation shown on **PAGE 1**.

Loosely attach to the driver side plate assembly using two 1/2" hex flange nuts (6). One of the wire harness clips may need to be unfastened from the inside of the driver side frame rail on some models for the U-bolt to be positioned.

12. Clamp the driver side plate assembly between the rubber bump stop and frame rail using the supplied 7/16" conical toothed washers (7) and M10 - 1.5 x 40mm hex bolts (6). Use the M10 x 70mm bolts (9) if spacer block is present (the spacer block will be clamped between the driver side plate assembly and the rubber bump stop).

13. Attach driver side plate assembly to the cross arms by inserting 1/2" x 1 1/2" carriage bolts (2) with CM-SP3 spacers (3) in through the driver side plate (B) and out the cross arms (A). Attach with 1/2" hex flange nuts (6), see **PAGE 1**.

14. Insert the forward U-bolt (5) into position on the inside of the passenger side frame rail and loosely attach the passenger side plate assembly using two 1/2" hex flange nuts (6). Repeat steps 11 -13 on the passenger side with this plate assembly.

15. Torque all fasteners in the following order: **First:** Torque the center section to the front and rear cross arms. **Second:** Torque the side plates to the truck frame and U-bolts on both sides. **Third:** Torque the side plates to the front and rear cross arms. Torque all 1/2" fasteners to 110 ft-lbs, and M10 hardware to 45 ft-ibs.

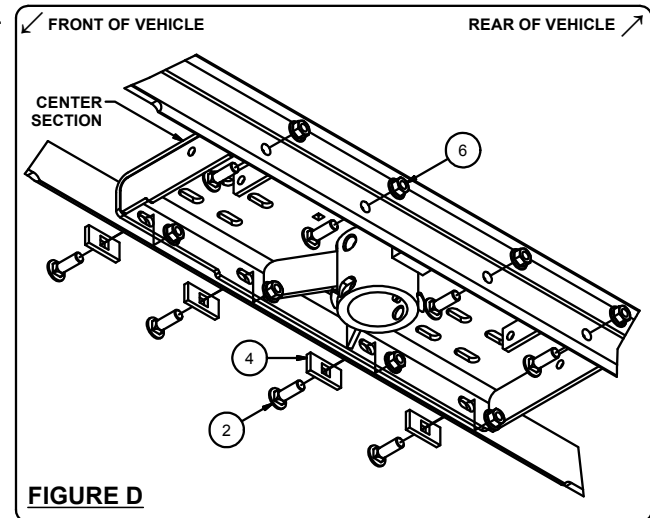

FIGURE D

(REFER TO GOOSENECK HITCH INSTRUCTIONS FOR INSTALLATION COMPLETION AND OPERATING PROCEDURES)

PERIODICALLY CHECK THIS GOOSENECK HITCH TO ENSURE THAT ALL FASTENERS ARE TIGHT AND THAT ALL STRUCTURAL COMPONENTS ARE SOUND.

Curt Manufacturing Inc., warrants this product to be free of defects in material and/or workmanship at the time of retail purchase by the original purchaser. If the product is found to be defective, Curt Manufacturing Inc., may repair or replace the product, at their option, when the product is returned, prepaid, with proof of purchase. Alteration to, misuse of, or improper installation of this product voids the warranty. Curt Manufacturing Inc.'s liability is limited to repair or replacement of products found to be defective, and specifically excludes liability for incidental or consequential loss or damage.

CAB TO TRAILER CLEARANCE

REMOVAL OF REAR WINDOW ACCESSORIES MAY BE REQUIRED.

TRAILER

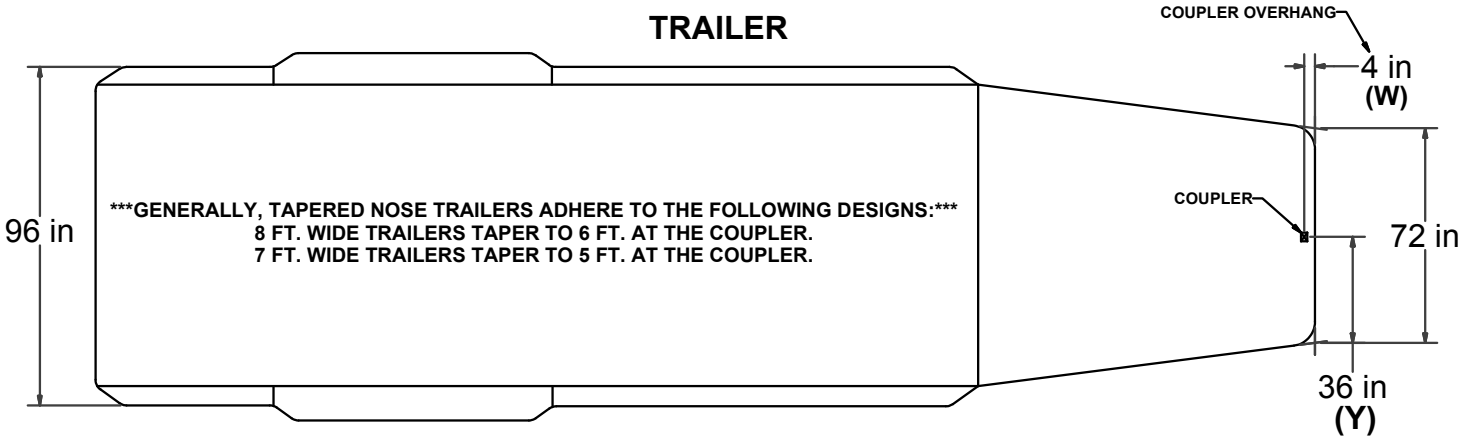

LONG & SHORT TRUCK BEDS

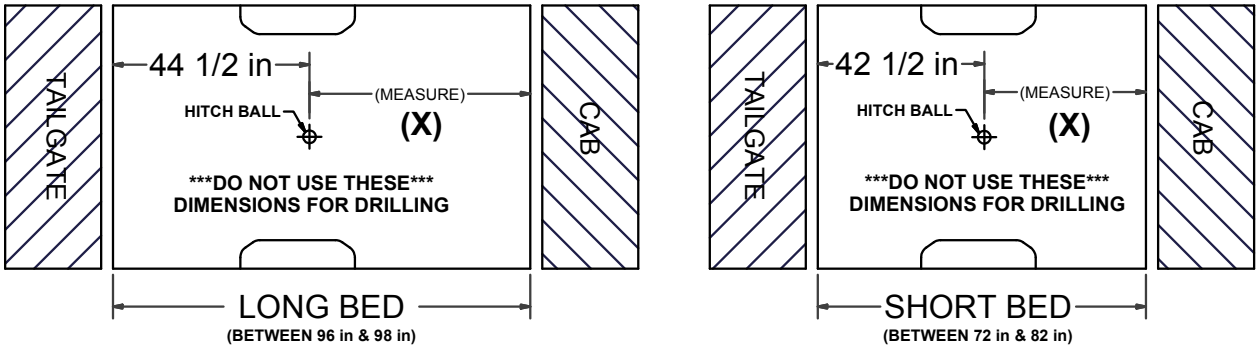

CLEARANCE CALCULATION

$$\text{(CAB TO BALL CENTER)} - \frac{1}{2} \text{(TRAILER WIDTH)} = \text{(MINIMUM CLEARANCE)}$$

$$(X) - (Y) = (Z)$$

IF THERE IS AN OVERHANG FROM THE COUPLER THEN THE EQUATION IS:

$$[(X) - (W)] - (Y) = (Z)$$

IF (Z) IS POSITIVE, TRAILER **WILL NOT** INTERFERE WITH CAB OF TRUCK.
 IF (Z) IS NEGATIVE, TRAILER **WILL** INTERFERE WITH CAB OF TRUCK!!!

EXAMPLE:

STANDARD TRAILER
 $X - Y = Z$
 $35 - 36 = -1$
 (TRAILER **WILL INTERFERE** WITH CAB)

TRAILER WITH OVERHANG
 $[(X) - (W)] - Y = Z$
 $[35 - 4] - 36 = -5$
 (TRAILER **WILL INTERFERE** WITH CAB)

YOUR CALCULATION:

(CAB TO BALL CENTER) _____

(COUPLER OVERHANG) _____

1/2 (TRAILER WIDTH) _____

(MINIMUM CLEARANCE) _____

Curt Manufacturing Inc., warrants this product to be free of defects in material and/or workmanship at the time of retail purchase by the original purchaser. If the product is found to be defective, Curt Manufacturing Inc., may repair or replace the product, at their option, when the product is returned, prepaid, with proof of purchase. Alteration to, misuse of, or improper installation of this product voids the warranty. Curt Manufacturing Inc.'s liability is limited to repair or replacement of products found to be defective, and specifically excludes liability for incidental or consequential loss or damage.