

31076

## TOYOTA 4RUNNER

GROSS LOAD CAPACITY WHEN USED AS A WEIGHT CARRYING HITCH: 3500 LBS. TRAILER WEIGHT & 350 LBS. TONGUE WEIGHT.  
 GROSS LOAD CAPACITY WHEN USED AS A STRAIGHT LINE PULL: 9,000 LBS. MAX. LINE PULL.



**WARNING: \*\*\* DO NOT EXCEED VEHICLE MANUFACTURER'S RECOMMENDED TOWING CAPACITY. \*\*\***



Parts List			
ITEM	QTY	PART NUMBER	DESCRIPTION
1	2	3/8"	CONICAL TOOTHED WASHER
2	2	M10-1.25 x 35 mm	HEX BOLT
3	2	1/2"	CONICAL TOOTHED WASHER
4	2	M12-1.25 x 35mm	HEX BOLT
5	2	5/8-11 x 2	CARRIAGE BOLT
6	2	5/8-11	HEX FLANGE NUT
7	2	31076-SP	ROUND HOLE SPACER

TOOLS REQUIRED	
RATCHET	
14mm, 17mm, 19mm, & 15/16" SOCKETS	
TORQUE WRENCH	
SAFETY GLASSES	

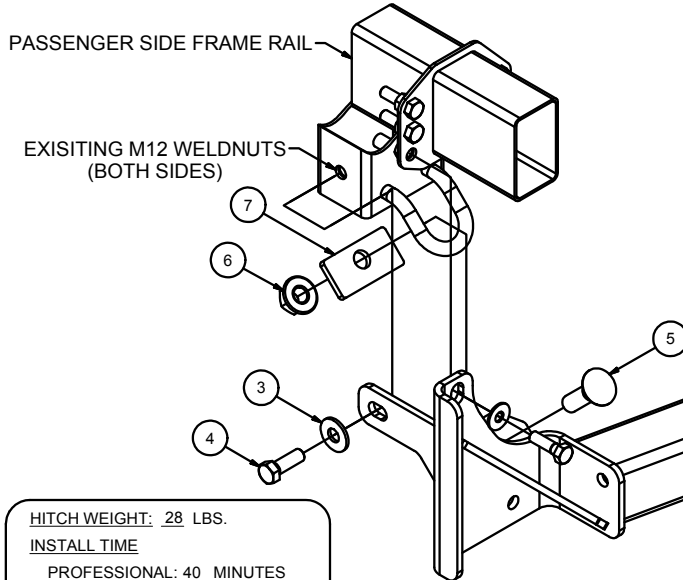
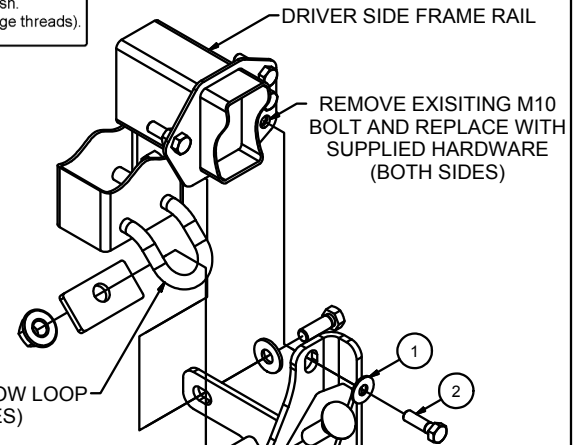
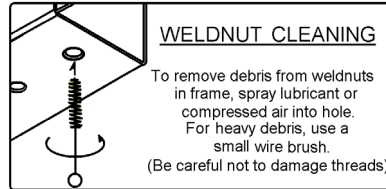
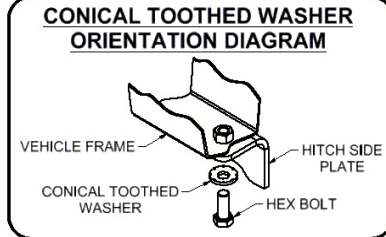

**HITCH WEIGHT:** 28 LBS.

**INSTALL TIME**

PROFESSIONAL: 40 MINUTES

NOVICE (DIY): 20 MINUTES

**INSTALL NOTES:**

- NO DRILLING REQUIRED

**REAR**  
**FRONT**

## INSTALLATION STEPS

1. Remove (1) hex bolt from the end of each frame rail with a 14mm socket (lowest outer bolt on each side) and return to vehicle owner. These will be replaced with the included M10 hardware.
2. Lift hitch into position, locating the vehicle's tow loops under the hitch mounting plates.
3. Loosely install the included M10 hex bolts with 3/8" conical tooth washers into weldnuts which bolts were removed in STEP 2.
4. Loosely install M12 bolts with 1/2" conical tooth washers into existing weldnuts on the outsides of frame rails.
5. Insert 5/8" carriage bolts through the hitch mounting plates and tow loops. Secure hitch to tow loops by attaching supplied spacers and 5/8" flange nuts to carriage bolts.
6. Torque all M10 fasteners to 48 ft-lbs, all M12 fasteners to 86 ft-lbs and all 5/8" fasteners to 210 ft-lbs.

**PERIODICALLY CHECK THIS RECEIVER HITCH TO ENSURE THAT ALL FASTENERS ARE TIGHT AND THAT ALL STRUCTURAL COMPONENTS ARE SOUND.**





Safety glasses should be worn at all times while installing this product.

YEARS: 2014-CURRENT

MAKE: TOYOTA

MODEL: 4RUNNER (EXCLUDING TRD PRO & LIMITED)

STYLE: SUV

**WARNING: NEVER EXCEED YOUR VEHICLE MANUFACTURER'S RECOMMENDED TOWING CAPACITY**

**WEIGHT CARRYING:**  
 TRAILER WEIGHT: 3500 LBS.  
 TONGUE WEIGHT: 350 LBS.

**GROSS LOAD CAPACITY WHEN USED AS A STRAIGHT LINE PULL:  
 9,000 LBS MAX.**

**PRO INSTALL TIME: 20 MIN.**  
**NOVICE INSTALL TIME: 40 MIN.**





IF YOU ARE HESITANT TO UNDERTAKE THIS TASK ON YOUR OWN, CONTACT AN AUTHORIZED CURT INSTALLER FOR ADDITIONAL ASSISTANCE.

**INSTALLATION TIPS:**



- BEFORE YOU BEGIN INSTALLATION, READ ALL INSTRUCTIONS THOROUGHLY.
- TO EASE INSTALLATION, 2 PEOPLE MAY BE REQUIRED.
- USING PROPER TOOLS WILL GREATLY IMPROVE THE QUALITY OF THE INSTALL AND REDUCE THE TIME REQUIRED.



**INSTALLATION REQUIRES:**

 RATCHET	 14mm 17mm 19mm 15/16" SOCKET	 TORQUE WRENCH
 SAFETY GLASSES		

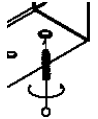
**LEVEL OF DIFFICULTY: EASY**

<b>EASY</b>	<b>MODERATE</b>	<b>CHALLENGING</b>
	WELDNUT CLEANING MAY BE REQUIRED	
	NO DRILLING REQUIRED	

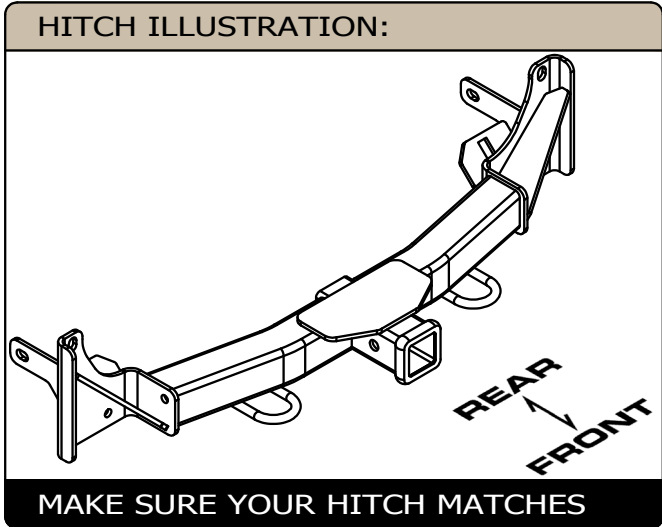

## INSTALLATION WALKTHROUGH:

Parts List			
ITEM	QTY	PART NUMBER	DESCRIPTION
1	2	3/8"	CONICAL TOOTHED WASHER
2	2	M10-1.25 x 35	HEX BOLT
3	2	1/2"	CONICAL TOOTHED WASHER
4	2	M12-1.25 x 35mm	HEX BOLT
5	2	5/8-11 x 2	CARRIAGE BOLT
6	2	5/8-11	HEX FLANGE NUT
7	2	31076-SP	ROUND HOLE SPACER

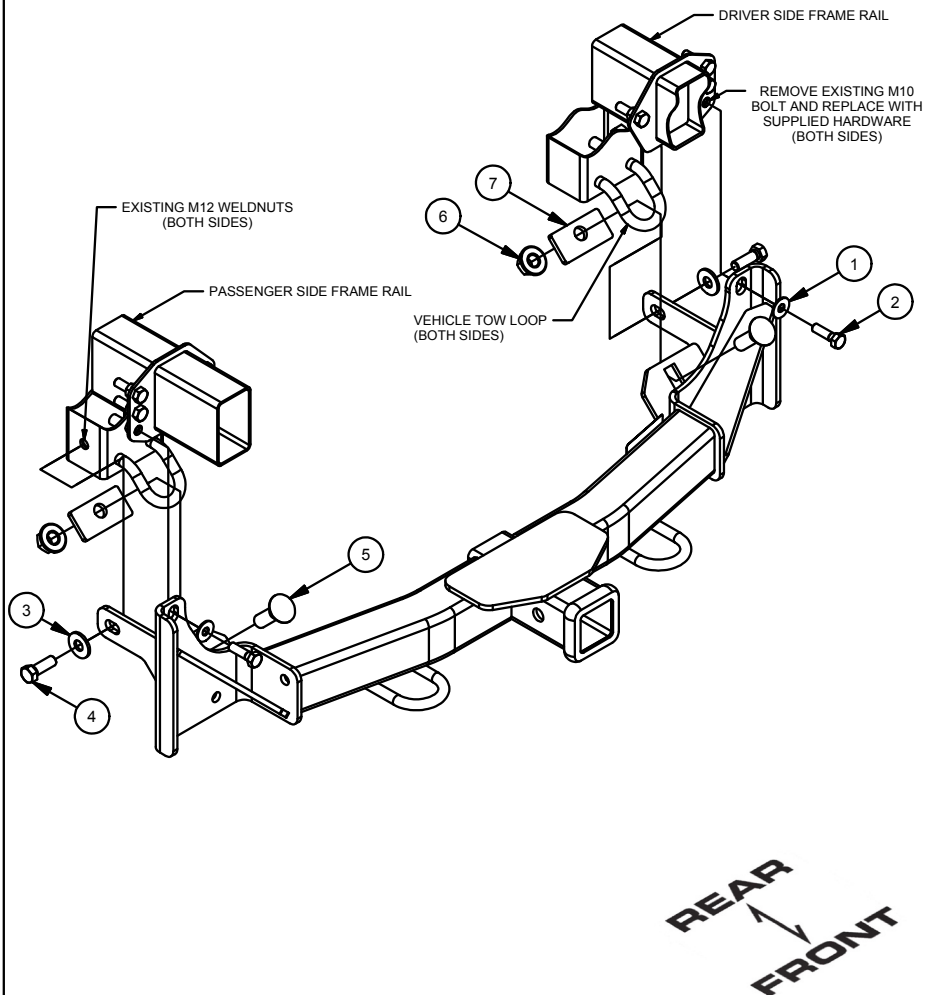

1. Remove one (1) hex bolt from the end of each frame rail with a 14mm socket (lowest outer bolt on each side) and return to vehicle owner. These will be replaced with the included M10 hardware.

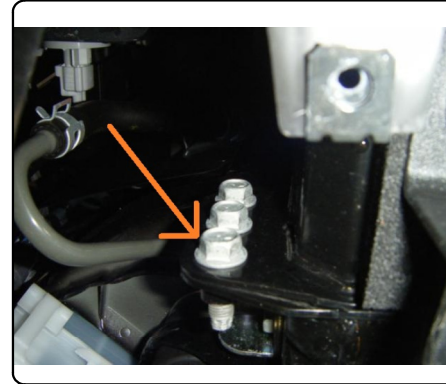

2. Lift hitch into position, locating the vehicle tow loops under the hitch mounting plates.



## INSTALLATION WALKTHROUGH:

3. Loosely install the included M10 hex bolts with 3/8" conical tooth washers as shown on the page 2 diagram.

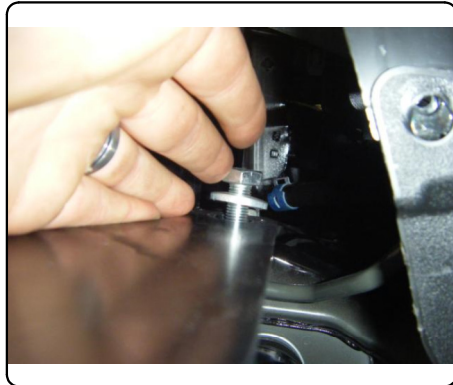
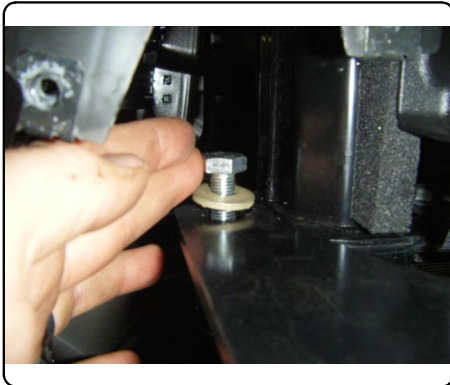

4. Loosely install M12 bolts with 1/2" conical tooth washers into existing weldnuts on the outsides of frame rails.

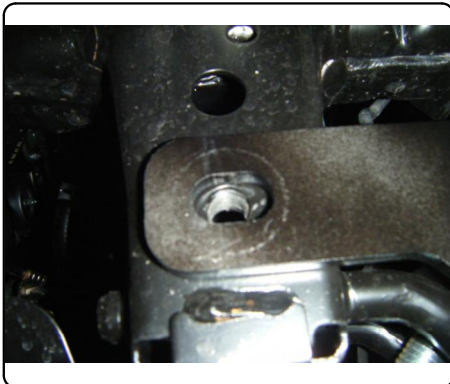

5. Insert 5/8" carriage bolts through the hitch mounting plates and tow loops. Secure hitch to tow loops by attaching supplied spacers and 5/8" flange nuts to carriage bolts.



6. Torque all M10 fasteners to 48 ft-lbs, all M12 fasteners to 86 ft-lbs and all 5/8" fasteners to 210 ft-lbs.



**\*\*\*DO NOT EXCEED VEHICLE MANUFACTURER'S RECOMMENDED TOWING CAPACITY \*\*\*.**

#### FRONT MOUNTED ACCESSORIES

1) Do not exceed front axle Gross Weight Rating (GAWR). Consult owners manual or specification plate located on driver's door frame. Measure gross front axle weight by placing front wheels of loaded vehicle on a scale.

**WARNING:** Exceeding GAWR may overload the front axle and/or suspension. This could result in **accident, property damage and personal injury.**

2) Reposition front mounted license plate if obstructed.

3) Do not obstruct vehicle lights.

4) Allow free air flow into grille opening.

5) Rear wheel traction may be reduced. This could effect handling. Reduce speed and drive with caution.

6) Accessories extend front of vehicle. This may reduce approach angle. Use caution when parking and maneuvering.

7) Do not obstruct driver view.

#### VEHICLE RECOVERY AND WINCHING TIPS

1) Use OEM tow hooks, recovery eyes or a clevis mount for attachment of a tow strap or winch cable.

**WARNING: NEVER** use a ball and/or ball mount as an anchor point for tow strap or winch cable. Severe personal injury or death could result.

2) Observe winch manufacturer's recommendations, cautions and warnings.

3) Attach return cable to tow hook or recovery eye when using a snatch block (See figure 1).

**CAUTION:** Do not attach return cable to winch mount. This may overload winch mount and/or front mounted receiver.

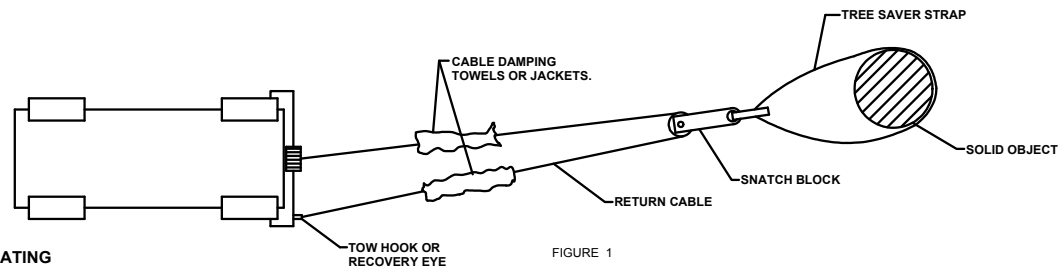

#### RATING

For **Maximum** line pull rating, winch cable must not exceed:

- 15 degree angle up or down from horizontal (See Figure 2).
- 45 degree angle left or right from straight ahead (See Figure 3).

**CAUTION:** Exceeding the maximum line pull rating may over load winch, winch mount, and/or front mounted receiver.

