

16424

FORD F-250, F-350 & F-450 (6 1/2' & 8' BOX)

5/31/2013

*****DO NOT EXCEED VEHICLE MANUFACTURER'S RECOMMENDED TOWING CAPACITY.*****

Parts List			
ITEM	QTY	PART NUMBER	DESCRIPTION
1	4	1/2-13 x 1 1/2	CARRIAGE BOLT
2	4	CM-SP17	.250 x 1.25 x 2.50" SQUARE HOLE SPACER
3	10	1/2 - 13 x 2	CARRIAGE BOLT
4	10	CM-SP136	.313" x 1.00 x 2.00" U-SHAPE SPACER
5	10	CM-SP33	.250 x 1.50 x 2.00" SQUARE HOLE SPACER
6	14	HFN 1213	HEX FLANGE NUT
7	2	3_4 - 10 x 2 1/2 HEX	HEX HEAD BOLT-NC
8	2	CM-SP41	.188 x 1.38 x 1.50" ROUND HOLE SPACER
9	2	3_4 - 10 HFN	HEX FLANGE NUT
10	1	1_2 FISHWIRE	1/2" FISHWIRE

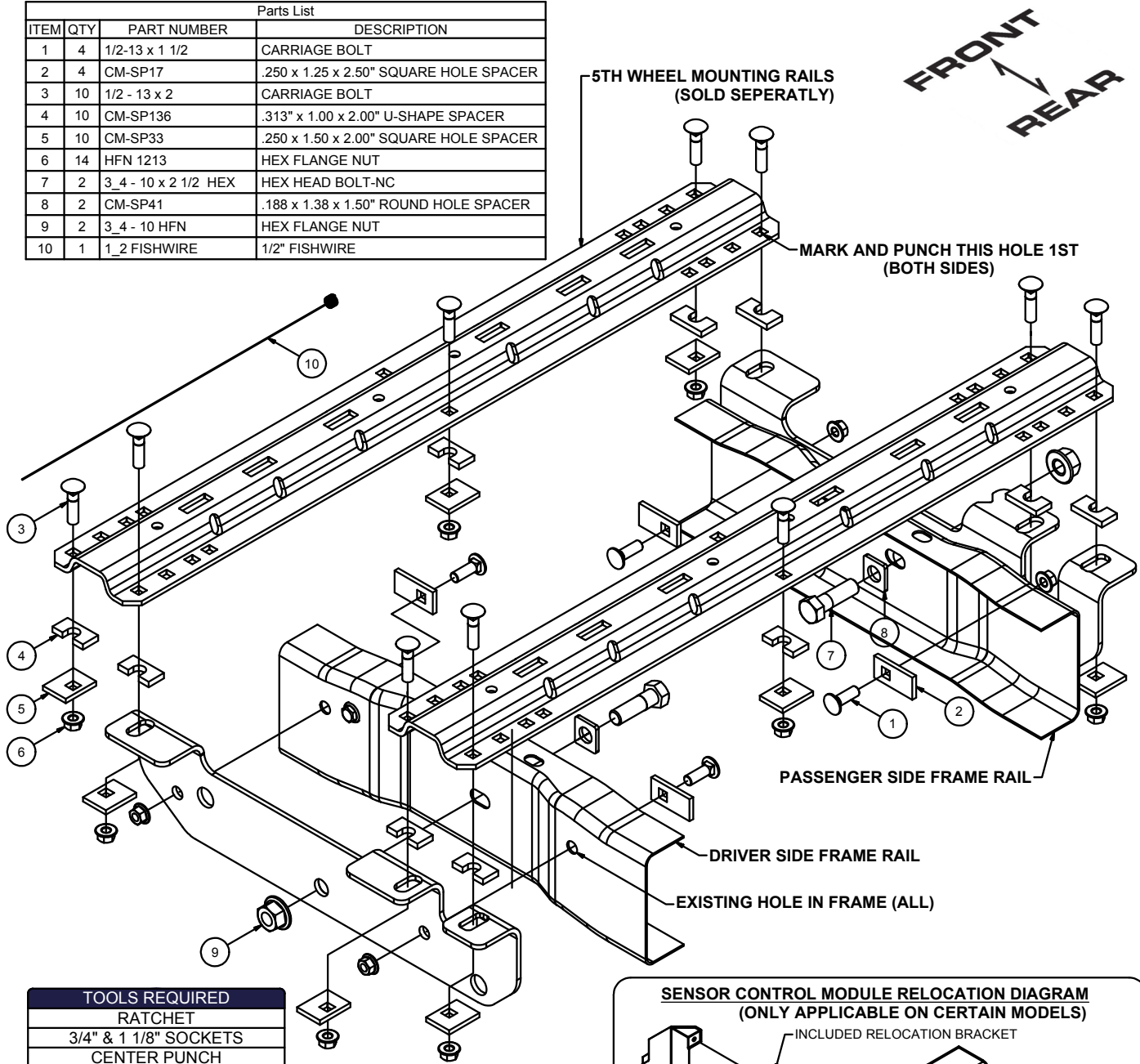

TOOLS REQUIRED	
RATCHET	
3/4" & 1 1/8" SOCKETS	
CENTER PUNCH	
DRILL	
1/8" & 9/16" DRILL BITS	
TAPE MEASURE	
TORQUE WRENCH	

HITCH WEIGHT: 24 LBS.
 INSTALL TIME
 PROFESSIONAL: 75 MINUTES
 NOVICE (DIY): 150 MINUTES
 INSTALL NOTES:
 - NO DRILLING INTO FRAME REQUIRED
 - LOWER SPARE TIRE FOR EASE OF INSTALLATION

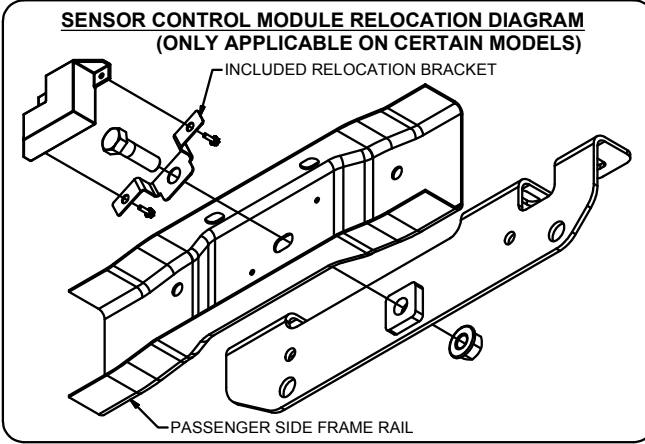

PERIODICALLY CHECK THIS RECEIVER HITCH TO ENSURE THAT ALL FASTENERS ARE TIGHT AND THAT ALL STRUCTURAL COMPONENTS ARE SOUND.

Curt Manufacturing LLC., warrants this product to be free of defects in material and/or workmanship at the time of retail purchase by the original purchaser. If the product is found to be defective, Curt Manufacturing LLC., may repair or replace the product, at their option, when the product is returned, prepaid, with proof of purchase. Alteration to, misuse of, or improper installation of this product voids the warranty. Curt Manufacturing LLC.'s liability is limited to repair or replacement of products found to be defective, and specifically excludes liability for incidental or consequential loss or damage.

16424

FORD F-250, F-350 & F-450 (6 1/2' & 8' BOX)

*****DO NOT EXCEED VEHICLE MANUFACTURER'S RECOMMENDED TOWING CAPACITY.*****

RAIL LOCATION DIAGRAM

!!IMPORTANT!
SYSTEM MAY NOT WORK WITH
2003 AND EARLIER COMPETITOR
PRODUCTS

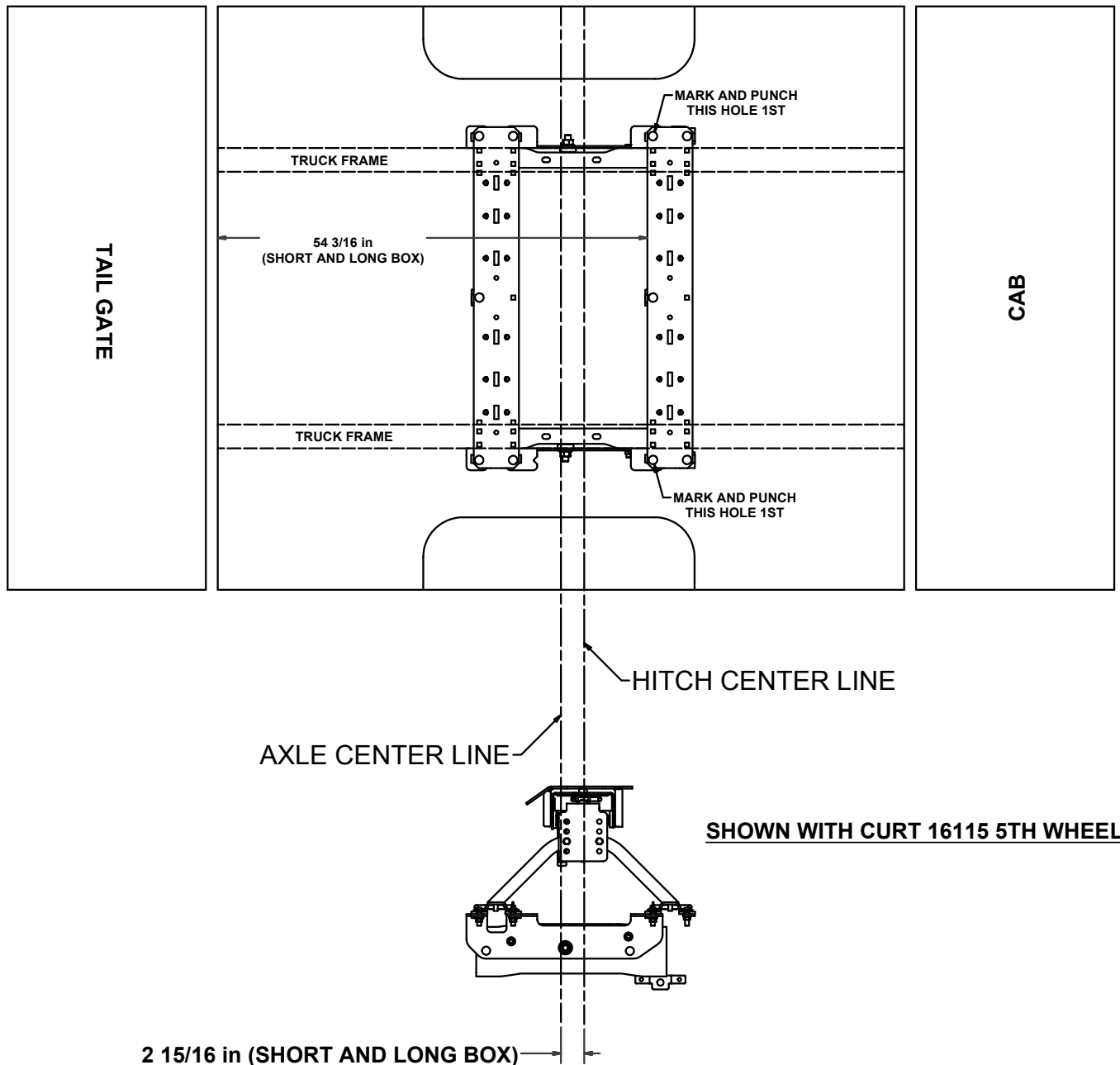

Curt Manufacturing Inc., warrants this product to be free of defects in material and/or workmanship at the time of retail purchase by the original purchaser. If the product is found to be defective, Curt Manufacturing Inc., may repair or replace the product, at their option, when the product is returned, prepaid, with proof of purchase. Alteration to, misuse of, or improper installation of this product voids the warranty. Curt Manufacturing Inc.'s liability is limited to repair or replacement of products found to be defective, and specifically excludes liability for incidental or consequential loss or damage.

16424

FORD F-250, F-350 & F-450 (6 1/2' & 8' BOX)

*****DO NOT EXCEED VEHICLE MANUFACTURER'S RECOMMENDED TOWING CAPACITY.*****

!WARNING!

- Do not install mounting rails over plastic bed liners. Plastic bed liners must be cut out of the way to provide metal to metal contact. Base rails may be installed on spray in liners.
- Use only bolts, nuts, and washers supplied to install this kit. All bolts are grade 5 and nuts are grade 5 unless specified otherwise.
- These instructions are guidelines only, actual installation is the responsibility of the installer and the owner. Always measure truck and trailer before installing hitch to be sure that there is clearance at the cab and at the bumper to allow for turns.
- During installation, when drilling, protect the fuel tank and filler tubes, brake lines, and wire harness by placing a piece of metal between the box floor and potential components at risk on the driver side. This will prevent drilling into these items.

1. Place one mounting rail in the box of the truck, using your tape measure, center the rail between the weld seams on the length of the truck box floor and the proper distance from the rear edge of the truck box as shown on the "Rail Location Diagram" on page 2.
2. Mark and center punch the holes as per the install diagram.
3. Temporarily position the side plate on the outside of the frame and check that the punches from step 3 align with the slots of the side plate. Remove the side plate & mounting rail from the vehicle and drill hole with a 1/8" drill bit.

WARNING: When drilling holes be aware of potential risks to vehicle components and make appropriate safe guards to protect them from damage.

4. Enlarge the 1/8" drilled holes with a 9/16" drill bit. (Use of a step drill will ease the drilling process.)
5. Place the driver side plate into position. Bolt head in frame should be located in the side plate clearance hole. Attach the side plate to the frame of the vehicle with the 1/2" x 1 1/2" carriage bolts and SP17 spacers provided, as shown on page 1. Tighten snug with 1/2" hex flange nuts to keep the side plate from moving.

NOTE: Diesel models will need the front driver side 1/2" x 1 1/2" carriage bolt and spacer fishwired into position using the included 1/2" fishwire because of blocked access due to the DEF tank.

6. Place the passenger side plate into position. The clearance hole should be located over the rivet in frame. Attach the side plate to the frame of the vehicle with the 1/2" x 1 1/2" carriage bolts and SP17 spacers provided, as shown on page 1. Tighten snug with 1/2" hex flange nuts to keep the side plate from moving.
7. Reposition the mounting rail over the holes.
8. Install the 1/2" x 2" carriage bolts with CM-SP136 (u-shaped spacers) to be located in the corrugation between the box and the side plates.

NOTE: The u-shaped spacer will have to be installed before inserting the 1/2" x 2" carriage bolts through the mounting rail and box floor. This insures a metal to metal contact. Attach with spacers and flange nuts as shown and tighten snug to keep the mounting rail from moving.

9. Place the unassembled 5th wheel / roller / gooseneck hitch into the already installed mounting rail. Position the second mounting rail with the 5th wheel / roller / gooseneck hitch by inserting the tabs into the mounting rail and pushing the mounting rail tight towards the other mounting rail. Ensure that the mounting rail is centered between the weld seams on the length of the truck box floor. This will position the mounting rail in the correct location and ensure that the 5th wheel will have a snug fit to the truck.

NOTE: If more than one hitch product will be used with the rails then both should be used at the same time to align the second rail. This will ensure that one product does not compromise the fit of the other.

10. See page 1 for all hardware locations. Repeat steps 3, 4, 5, 6, 7, 8 and 9. Insert 3/4" x 2 1/2" hex bolts with CM-SP41 spacers into the center hole on each side plate and fasten with 3/4" hex flange nuts.

NOTE: If sensor control module is located on the inside of the frame rail preventing the installation on the 3/4" x 2 1/2" hex bolts relocate with the included relocation bracket. See sensor control module relocation diagram on page 1.

11. Torque all 1/2" fasteners to 110 lb-ft, and all 3/4" fasteners to 380 lb-ft. Torque the mounting rails to the side plates first then torque remaining fasteners.