

*****DO NOT EXCEED VEHICLE MANUFACTURER'S RECOMMENDED TOWING CAPACITY.*****

Parts List			
ITEM	QTY	PART NUMBER	DESCRIPTION
1	1	16411-DS	DRIVER SIDE PLATE
2	1	16411-PS	PASSENGER SIDE PLATE
3	4	5/8-11 x 1 3/4	CARRIAGE BOLT
4	4	CM-SP9	.250 x 1.25 x 2.50" SQUARE HOLE SPACER
5	4	5/8-11	HEX FLANGE NUT
6	10	1/2 - 13 x 2"	CARRIAGE BOLT
7	10	CM-SP136	.313" x 1.00 x 2.00" U-SHAPE SPACER
8	10	CM-SP33	.250 x 1.50 x 2.00" SQUARE HOLE SPACER
9	10	HFN 1213	HEX FLANGE NUT
10	2	5_8 FISHWIRE	5/8" FISHWIRE
11	4	M16 - 2.00 x 35 HHCS	M16 - 2.00 x 35 HHCS GR10.9 YZ
12	4	5_8 LOCK WASHER	HELICAL LOCK WASHER
13	4	5_8 WASHER	WASHER

TOOLS REQUIRED
RATCHET
3" & 6" SOCKET EXTENSION
TORQUE WRENCH
CRESCENT WRENCH
3/4" BOX END WRENCH
13mm, 24mm, 3/4", 15/16" SOCKETS
DRILL
1/8" AND STEP DRILL BITS
SAFETY GLASSES

NOTE: NOT ALL HARDWARE WILL BE USED

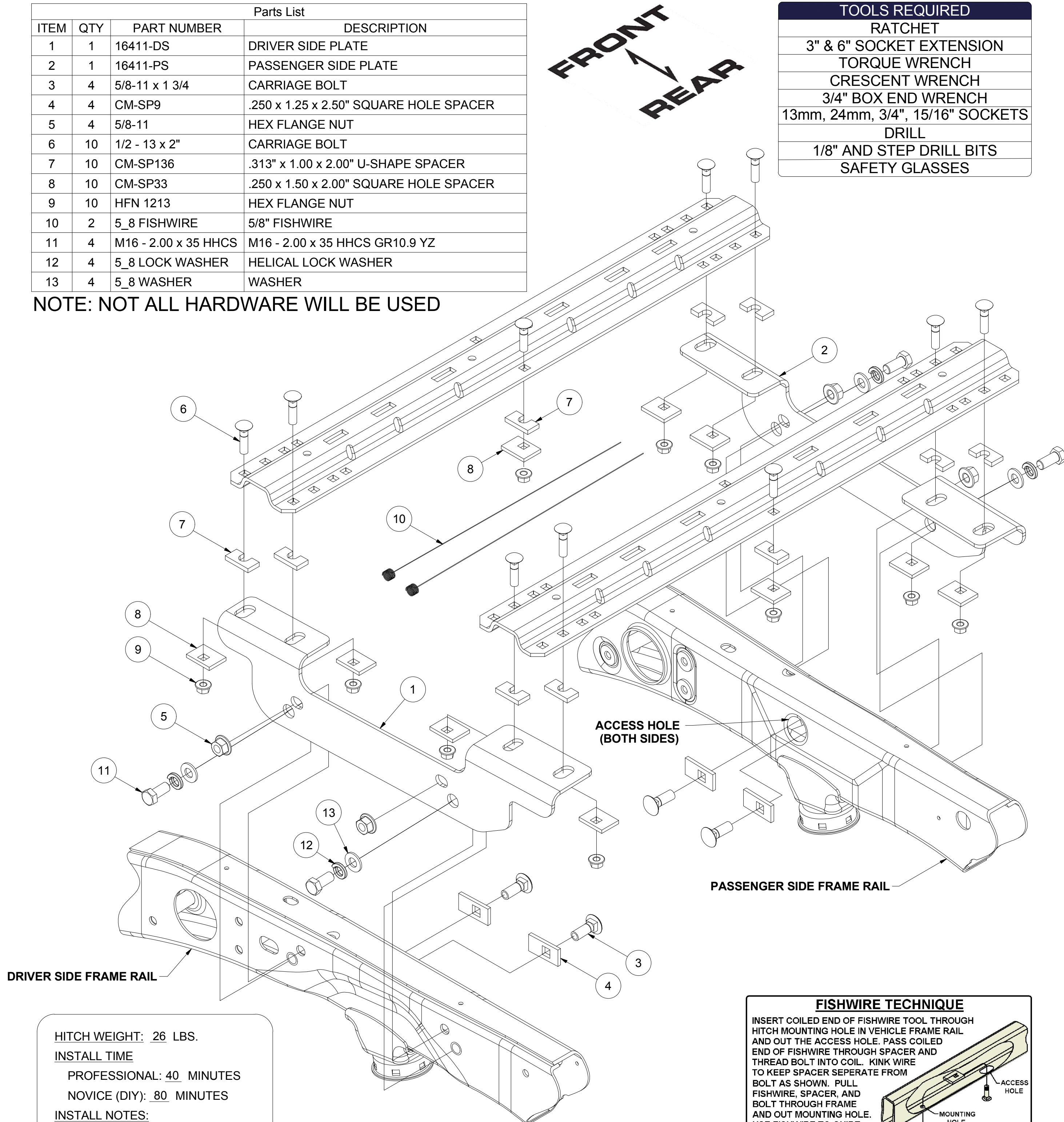

HITCH WEIGHT: 26 LBS.

INSTALL TIME

PROFESSIONAL: 40 MINUTES

NOVICE (DIY): 80 MINUTES

INSTALL NOTES:

- FISHWIRE HARDWARE
- NO DRILLING REQUIRED

FISHWIRE TECHNIQUE

INSERT COILED END OF FISHWIRE TOOL THROUGH HITCH MOUNTING HOLE IN VEHICLE FRAME RAIL AND OUT THE ACCESS HOLE. PASS COILED END OF FISHWIRE THROUGH SPACER AND THREAD BOLT INTO COIL. KINK WIRE TO KEEP SPACER SEPARATE FROM BOLT AS SHOWN. PULL FISHWIRE, SPACER, AND BOLT THROUGH FRAME AND OUT MOUNTING HOLE. USE FISHWIRE TO GUIDE HITCH DURING MOUNTING AND PREVENT LOSS OF BOLT / SPACER INSIDE FRAME RAIL.

NOTE: SOME VEHICLES MAY FISHWIRE THROUGH END OF FRAME

PERIODICALLY CHECK THIS RECEIVER HITCH TO ENSURE THAT ALL FASTENERS ARE TIGHT AND THAT ALL STRUCTURAL COMPONENTS ARE SOUND.

RAIL LOCATION DIAGRAM

!IMPORTANT!
SYSTEM MAY NOT WORK WITH
2003 AND EARLIER COMPETITOR
PRODUCTS

REAR MOUNTING RAIL USES SECOND
HOLES IN FROM OUTSIDE

FORWARD MOUNTING RAIL USES
THE OUTER MOST HOLES

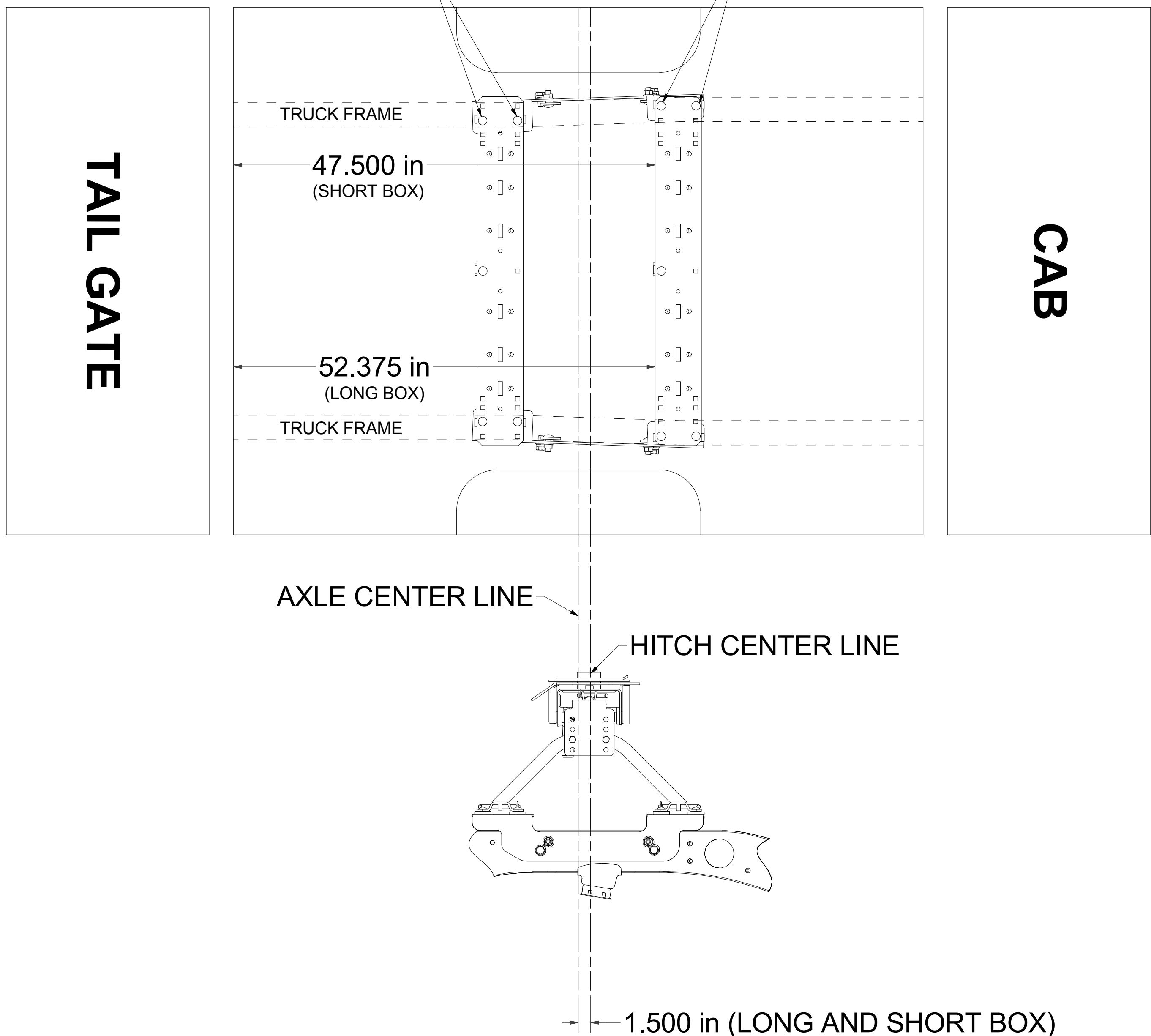

**PERIODICALLY CHECK THIS RECEIVER HITCH TO ENSURE THAT ALL FASTENERS
ARE TIGHT AND THAT ALL STRUCTURAL COMPONENTS ARE SOUND.**

Curt Manufacturing Inc., warrants this product to be free of defects in material and/or workmanship at the time of retail purchase by the original purchaser. If the product is found to be defective, Curt Manufacturing Inc., may repair or replace the product, at their option, when the product is returned, prepaid, with proof of purchase. Alteration to, misuse of, or improper installation of this product voids the warranty. Curt Manufacturing Inc.'s liability is limited to repair or replacement of products found to be defective, and specifically excludes liability for incidental or consequential loss or damage.

!WARNING!

- Do not install mounting rails over plastic bed liners. Plastic liners must be trimmed for metal-to-metal contact. May be installed on spray in liner.
- Use only supplied fasteners for installation.
- Before installing hitch measure to be sure there will be enough clearance between the truck and trailer to allow for turns.
- Frame rail must be clear of any electrical or brake components where side plates attach.

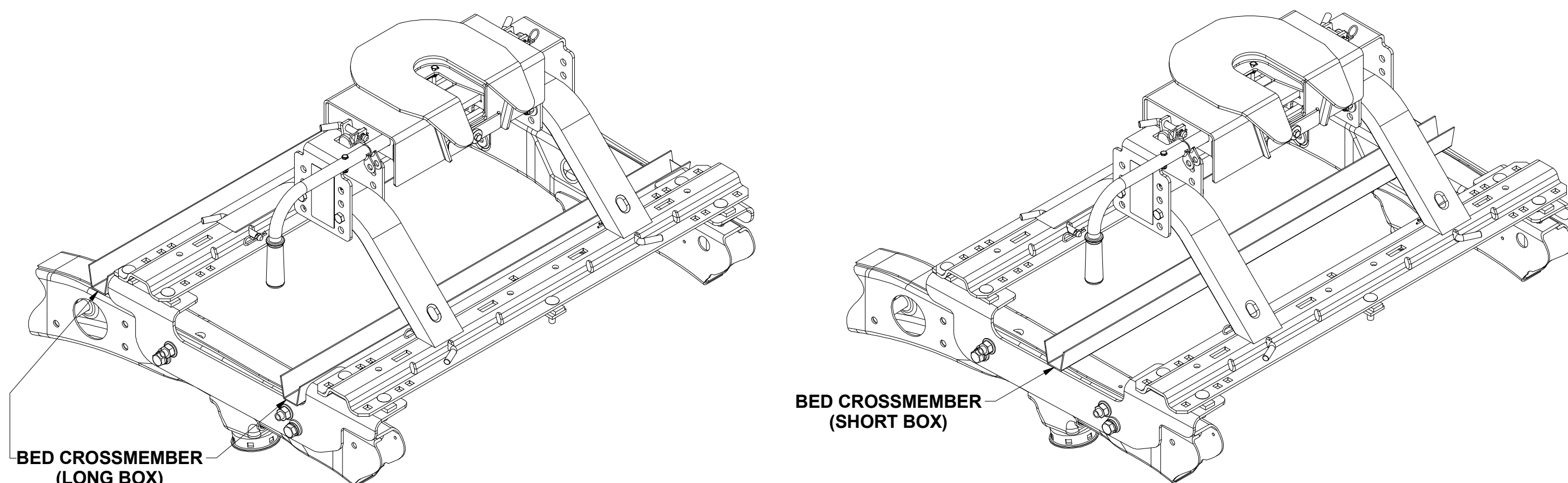
**INSTALLATION STEPS**

1. Place one mounting rail in the box of the truck, using your tape measure, center the rail on the truck box floor at the proper distance from the rear edge of the truck box as shown on the "RAIL LOCATION DIAGRAM" on page 2.
2. Remove inner plastic fender liner (if present) by removing (4) screws and (3) plastic fasteners.
3. Using a center punch, mark the holes as per the rail location diagram. Drill (1) hole first and check by temporarily positioning the side plate on the side of the frame. Move the mounting rail out of the way and drill each position with a 1/8" drill bit.

NOTE: Use the outermost holes for drilling locations on forward mounting rail. Use the second holes in from the outside on rear mounting rail.

4. Temporarily position the side plates on the sides of the frame and check that all the 1/8" drilled holes align with the slots of the side plates. Remove the side plates from the vehicle.

NOTE: Move any electrical or braking components that may be trapped between the frame and side plates.

5. Enlarge the 1/8" drill holes to 9/16" with a step drill bit.
6. **2015 and older models:** Fishwire 5/8" carriage bolts and CM-SP9 spacers through the access hole and into position, as shown on page 1. Leave fishwires attached and raise the side plate into position. Finger tighten the side plate to the side of the frame using the 5/8" flange nuts. See "FISHWIRE TECHNIQUE" on page 1. Repeat on other side.
2016 and newer models: Raise side plate into position and use (2) M16 bolts, (2) 5/8" lock washers, and (2) 5/8" washers to attach side plate to frame as shown on page 1. Repeat on other side.
7. Reposition the mounting rail over the holes and fasten the mounting rail to the side plates using the supplied 1/2" carriage bolts. Use the supplied CM-SP33 and CM-SP136 spacers between the frame bracket or mounting rails and the truck box to ensure a metal to metal contact and to eliminate "rib crush" of the bed. Use of a gear wrench will ease the tightening process.
8. Place the unassembled 5th wheel / roller / gooseneck hitch into the already installed mounting rail. Position the second mounting rail with the 5th wheel / roller / gooseneck hitch by inserting the tabs into the mounting rail and pushing the mounting rail tight towards the other mounting rail. Ensure that the mounting rail is centered on the truck box floor. This will position the rail in the correct location and ensure that the 5th wheel will have a snug fit to the truck. To ease the process of tightening rear fasteners remove the spare tire and fasteners from heat shield.

NOTE: If more than one hitch product will be used with the mounting rails then both should be used at the same time to align the second mounting rail. This will ensure that one product does not compromise the fit of the other.

9. Repeat steps 3, 4, 5, 6 and 7
10. Torque all 1/2" hardware to 110 ft-lbs. Torque all 5/8" hardware to 210 ft-lbs. Torque all M16 hardware to 195.4 ft-lbs.
PERIODICALLY CHECK THIS RECEIVER HITCH TO ENSURE THAT ALL FASTENERS ARE TIGHT AND THAT ALL STRUCTURAL COMPONENTS ARE SOUND.