

**Vehicle Applications**

**CHRYSLER**  
2011 – 2014 300

**DODGE**  
2011 – 2014 Charger  
2011 – 2015 Journey

**Navigation / Radio Compatibility**

Uconnect 8.4" Screen / 2 piece radio with 22-pin connector

**Parts Included**



UC-2 Interface Module

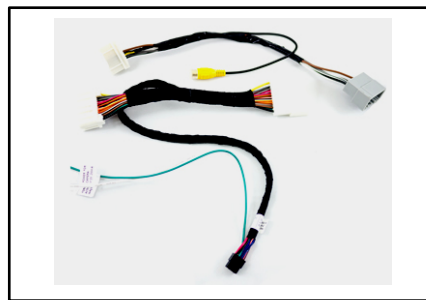

CH-22 Harness

**Wiring Diagram**

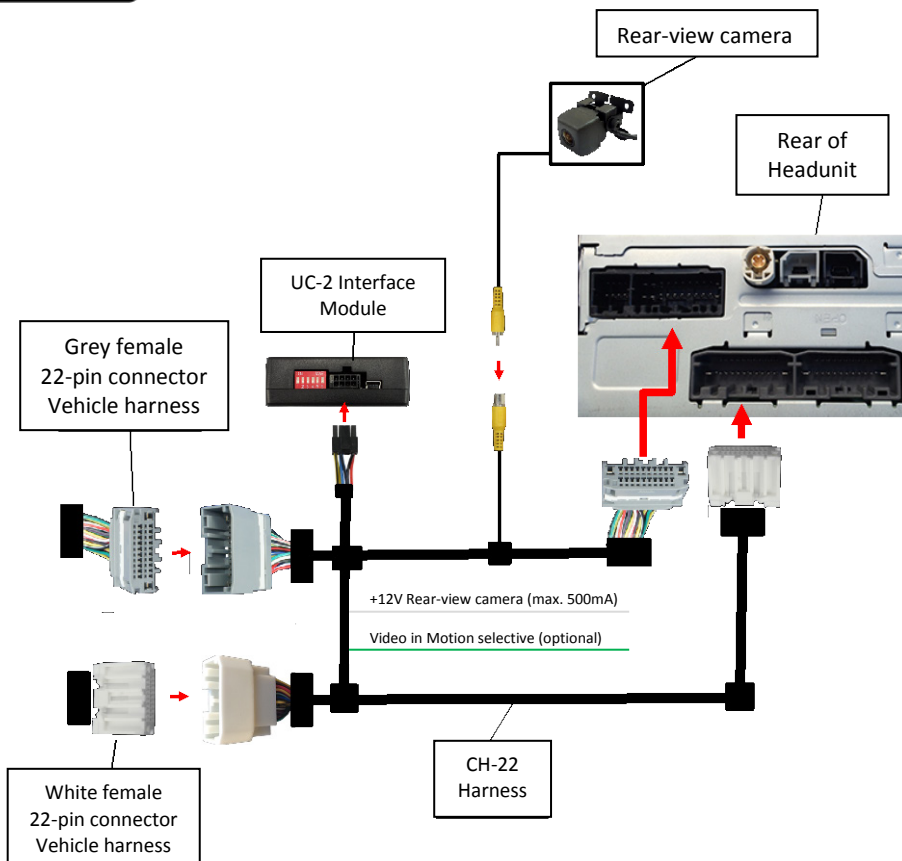

continued

**Installation Instructions****DIP Switch Setting**

Vehicle/ navigation	DIP 1	DIP 2	DIP 3	DIP 4	DIP 5	DIP 6
Video-in-motion permanent	ON	ON	OFF	OFF	OFF	OFF
Video-in-motion selective*	OFF	ON	OFF	OFF	OFF	OFF

\*With DIP 1 set to OFF, the green wire is used to activate selective video-in-motion function.

**DIP switch functions of the UC-2**

DIP 1 – Activate Video in Motion

DIP 2 – Activate Rear-view camera

DIP 3 – no function

DIP 4 – no function

DIP 5 – CAN-bus termination resistor on the vehicle side

DIP 6 – CAN-bus termination resistor on the head-unit side

**Pin-assignment (8pin Molex)**

Cable colour	Pin-No.	Assignment
● Yellow	Pin 4	CAN-HIGH – connection to the head-unit
● Blue	Pin 3	CAN-LOW – connection to the head-unit
●● Yellow/Black	Pin 8	CAN-HIGH – connection to the vehicle
●● Blue/Black	Pin 7	CAN-LOW – connection to the vehicle
● Red	Pin 1	+12V Constant
● Black	Pin 5	Ground
● Green	Pin 6	Activation of the video-in-motion function (+12V = Video In Motion, only if DIP1=OFF)
● White	Pin 2	Reverse Trigger output (+12V DC 500mA) (only if DIP2=ON and reverse gear engaged!)

continued

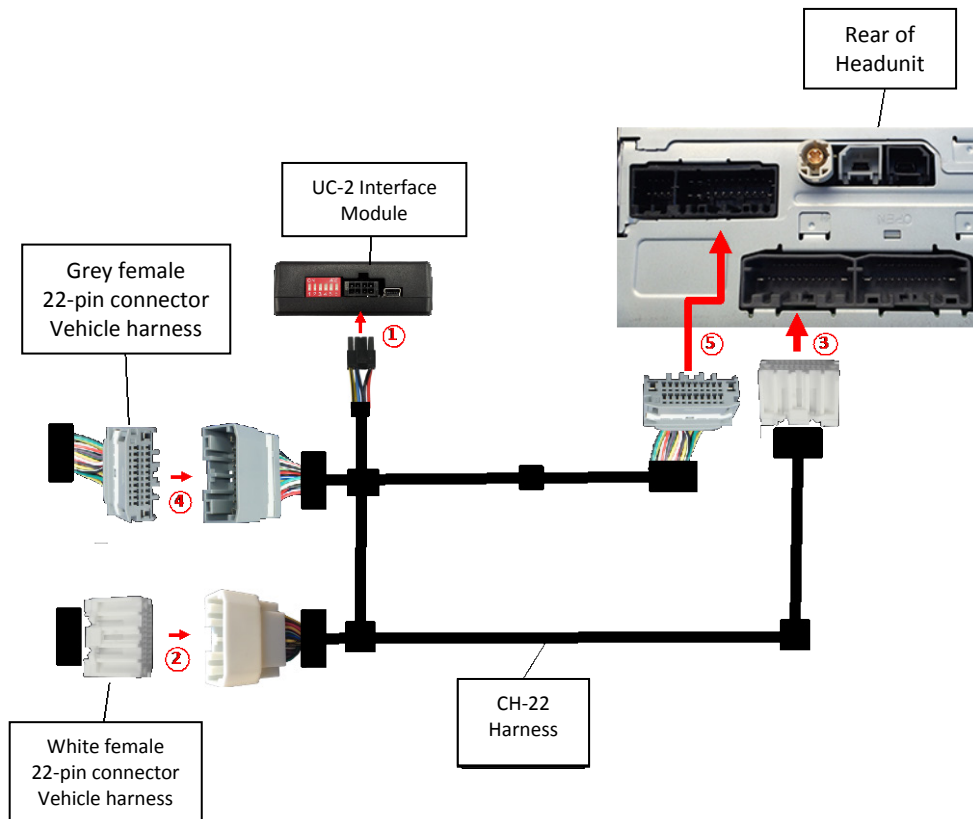
**Connecting the CAN interface to the factory navigation**

- ① Connect female 8-pin Molex connector of harness CH-22 to male 8-pin Molex connector of CAN Interface.
- ② Transfer white female 22-pin connector of vehicle harness from rear of the head-unit into male white female 22-pin connector of harness CH-22.
- ③ Plug white female 22-pin connector of harness CH-22 into male 22-pin connector on the rear of the head-unit.
- ④ Transfer grey female 22-pin connector of vehicle harness from rear of the head-unit into male grey female 22-pin connector of harness CH-22.
- ⑤ Plug grey female 22-pin connector of harness CH-22 into male 22-pin connector on the rear of the head-unit.

continued

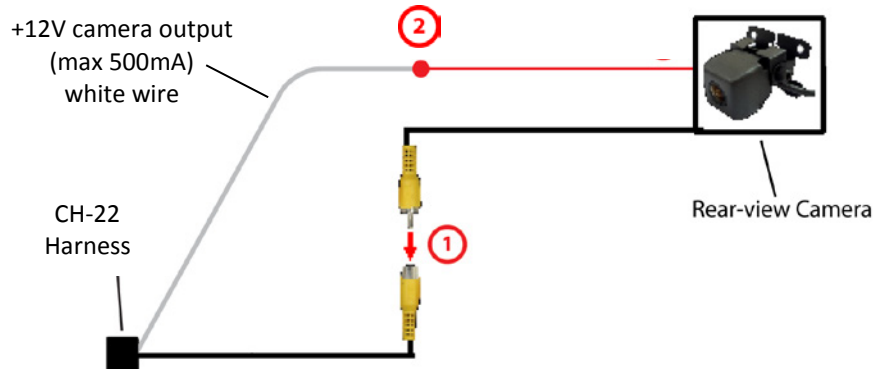
**Connections to rear-view camera**

- ① Connect the video RCA of the rear-view camera to the female RCA connector of the harness CH-22.
- ② Connect the white wire of harness CH-22 to the camera power supply (+12V max 500mA). The white wire gets power when reverse gear is engaged.

**Coding of the rear-view camera**

1. Set DIP switch 2 to "OFF" position.
2. Turn on ignition.
3. Wait until the head-unit has booted.
4. Set DIP switch 2 to "ON" position.
5. After a short time, the system will reset and the coding operation is complete.

**Activation of rear-view camera**

The rear-view camera activate automatically whenever the reverse gear is engaged.

**Activation of the video-in-motion function**

The video-in-motion can be activated and deactivated by DIP 1 or alternatively by the included loose green cable in connection with a toggle switch (not included).

**Video-in-motion permanent**

Set DIP 1 to ON for the video-in-motion function to be activated permanently without disrupting the navigation performance.

**Video-in-motion selective**

Set DIP 1 to OFF and use the green wire to activate the video-in-motion function.

Connect a toggle switch between a +12V ACC source and the green wire.

- +12V = Video in Motion is activated
- 0V = Video in Motion is not activated