

## PRODUCT FEATURES:

- Retains factory features in select Lexus and Toyota vehicles with JBL Harman-Becker Digital-Synthesis Amplifier, including JBL (Pioneer-made) amplifiers while functioning with an aftermarket radio.
- Pre-programmed to retain factory Steering Wheel Controls.
- Retains factory backup camera (if present).
- Retains OEM 3.5mm Auxiliary Audio Input.
- iPhone Voice Recognition (VR) feature from SWC on select Kenwood, Pioneer, Alpine and JVC radios.
- Variable audio gain adjustment to level match the aftermarket radio and factory amplifier.
- Supports BT-HF/A2DP/AVRCP profile on select aftermarket radio models.
- Supports Pick Up/End Call, Pick up and Toggle between 1st and 2nd incoming call, AVRCP Track, Seek.
- EIA color coded wiring for easy installation.

## NOTES:

1. Left-Right Balance Audio Control is supported. Front-Rear Audio Fading is not supported.
2. **Please make sure to set the factory radio volume to 70% and balance and fade options are centered before removing the radio.**

## PARTS INCLUDED:



SWRTY-61J Module



TY-A Harness  
(For Newer Models)

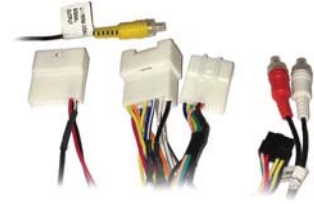

TY-B Harness  
(For Older Models)



3.5MM to 4-pin SWC Cables



OEM Camera Retention Harness



16 to 24 Pin Camera Adapter

## IMPORTANT INSTALLATION NOTES:

1. In some Lexus/Toyota vehicles 2006 and older, the mute circuit is located in the same pin location as the amplifier turn-on on the OEM harness. If no audio is heard after the installation is complete, disconnect the BLUE/WHITE wire on the TY-61J T-Harness from the aftermarket radio AMP Turn-on wire. Insulate with tape to avoid short circuits.
2. Before connecting the 3.5mm SWC Cable, thoroughly wipe it clean with the alcohol cleansing pad provided. This will ensure a solid contact with the aftermarket radio SWC circuit.
3. To retain the factory AUXILIARY INPUT option in the vehicle, the aftermarket radio must have an "Auxiliary Audio Input" feature. Please check your aftermarket radio manual for details.

## INSTALLATION DIAGRAM:

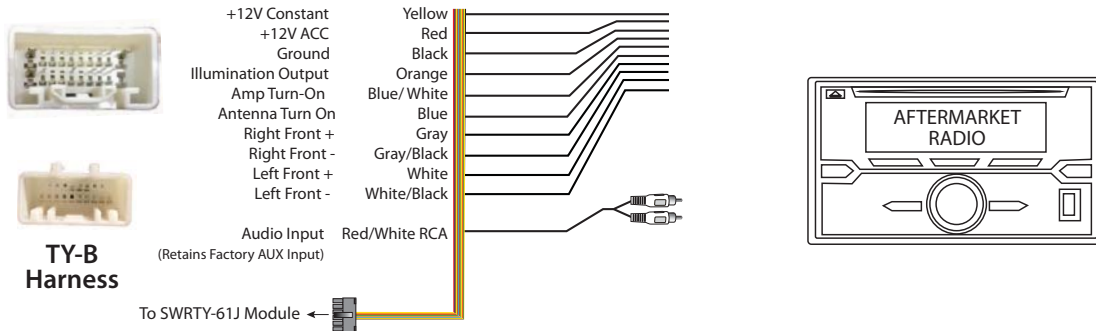
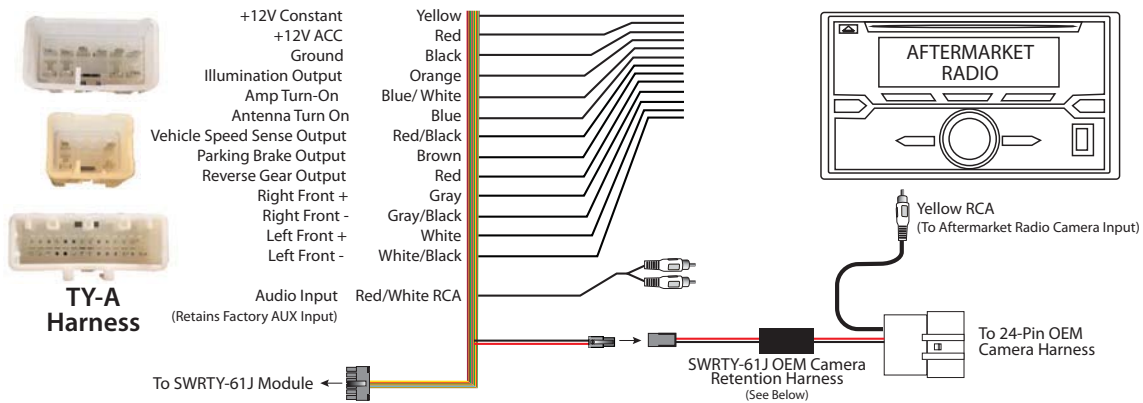

**NOTE:** Aftermarket radio rear speaker output leads are not used on both harnesses. Insulate with tape.

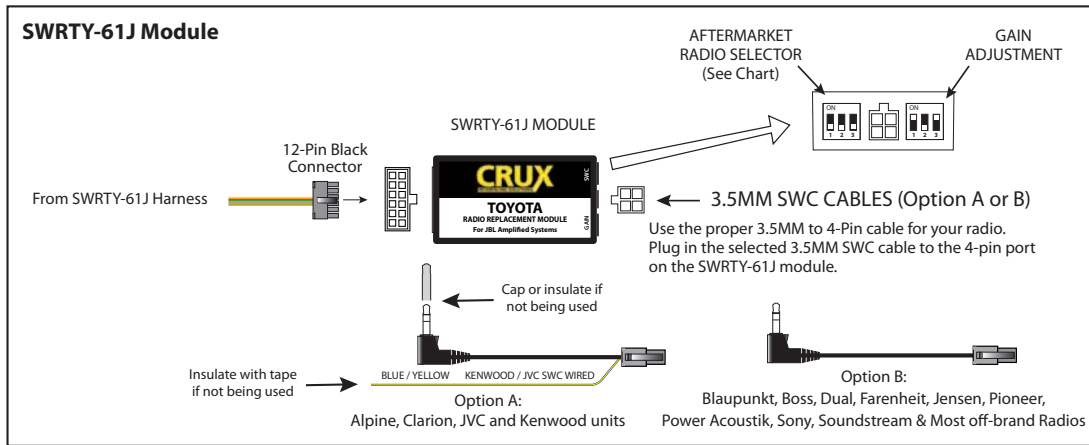

### SWRTY-61J OEM Camera Retention Harness

The SWRTY-61J includes a camera harness with a 12V to 6V voltage converter to retain the OEM camera (if equipped). Some older models use a 16-Pin OEM camera connector. In this case, use the supplied 16 to 24-Pin Camera Adapter.

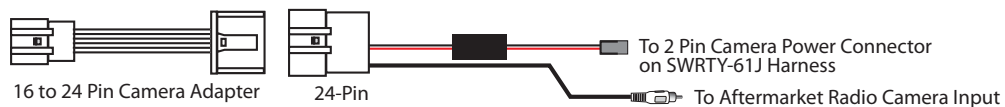

## SETTING THE AFTERMARKET RADIO BRAND

This step is done on the SWRTY-61J Module. With the key in the off position, set the DIP switches to the corresponding radio listed below.

RADIO BRAND:	DIP:	1	2	3
Atoto, Dual, Fahrenheit, Jensen, Pioneer		OFF	ON	ON
Power Acoustik, Soundstream		OFF	ON	ON
Blaupunkt, Most off brand Radios		OFF	ON	ON
Alpine		OFF	OFF	OFF
Clarion		ON	ON	OFF
Kenwood		ON	ON	ON
JVC		ON	OFF	ON
Sony, Boss		ON	OFF	OFF

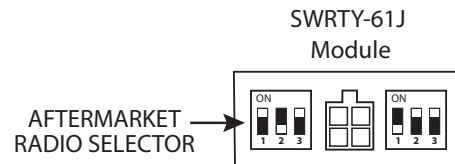

**NOTE:** For Atoto, Blaupunkt, Dual, Farenheit, Power Acoustik, Soundstream, and most off-brand radios, check the aftermarket radio's manual to see if the SWC buttons need to be programmed.

## 4-PIN SWC CABLE

Use the proper 3.5MM to 4-Pin SWC cable for the aftermarket radio you are using.

OPTION A is used for ALPINE, CLARION. For JVC and KENWOOD use the Blue/Yellow wire.  
OPTION B is used for ATOTO, BLAUPUNKT, BOSS, DUAL, FARENHEIT, JENSEN, POWER ACOUSTIK, PIONEER, SONY, SOUNDSTREAM and Most Off-Brand Radios.

NOTE: Cap or insulate the 3.5mm plug or Blue/Yellow wire if not being used.

For aftermarket radios that have wires for SWC connections, cut off the 3.5mm plug on the Crux SWC Cable and connect the SWC wires as follows:

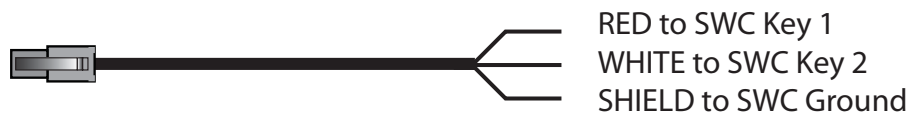

Note that there are some radios that only have SWC1 and SWC2, in this case "shield" does not need to be connected.

## GAIN ADJUSTMENTS:

Use the gain adjustment to level match the aftermarket radio audio output with the OE amplifier input.

DIP SETTING	dB	Volts
OFF OFF OFF	0 dB	
OFF OFF ON	1.7 dB	+7mV
OFF ON OFF	3.5 dB	+9mV
OFF ON ON	5.2 dB	+10mV
ON OFF OFF	7.2 dB	+15mV
ON OFF ON	9.1 dB	+18mV
ON ON OFF	11 db	+22mV
ON ON ON	12.9 dB	+27mV

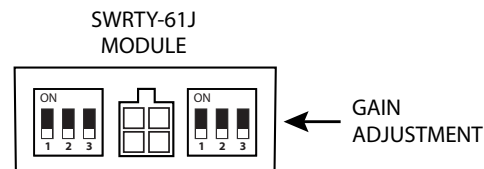

**STEERING WHEEL CONTROL BUTTON FUNCTIONS:**

<u>SWC Button</u>	<u>SHORT PRESS</u>	<u>LONG PRESS</u>
<b>PIONEER</b> VOL + VOL - Seek Up Seek Down Mode OFF Hook ON Hook Voice  *NOTE:	Step Increment Step Decrement Preset Up Preset Down Source Pick Up Call* End Call Activate VR/Deactivate VR  BT Mode Active: OFF Hook = Toggle between 1st and 2nd Call	Continuous VOL + Continuous VOL - Seek Up Seek Down Power On/Off None None None
<b>ALPINE</b> VOL + VOL - Seek Up Seek Down Mode OFF Hook ON Hook Voice  *NOTE:	Step Increment Step Decrement Seek Up Seek Down Source Pick Up Call End Call Activate VR*/Deactivate VR*  BT Mode Active: OFF Hook = Toggle between 1st and 2nd Call	Continuous VOL + Continuous VOL - None None None None None N/A
<b>CLARION</b> VOL + VOL - Seek Up Seek Down Mode OFF Hook ON Hook Voice  NOTE:	Step Increment Step Decrement Preset Up Preset Down Source Pick Up Call End Call Mute  BT Mode Active: OFF Hook = Toggle between 1st and 2nd Call	Continuous VOL + Continuous VOL - Seek Up Seek Down Power On/Off None None None
<b>JVC</b> VOL + VOL - Seek Up Seek Down Mode OFF Hook ON Hook Voice  *NOTE:	Step Increment Step Decrement Seek Up Seek Down Source Pick Up Call* End Call Activate VR  BT Mode Active: User must End 1st call in order to pick up 2nd incoming call.	Continuous VOL + Continuous VOL - M-Seek Up M-Seek Down Power On/Off None None None  Deactivate VR: Say "Cancel" or remain silent until it times out ➡ Auto switch back to previous Source.

<u>SWC Button</u>	<u>SHORT PRESS</u>	<u>LONG PRESS</u>
<b>KENWOOD</b> VOL + VOL - Seek Up Seek Down Mode OFF Hook  ON Hook Voice	Step Increment Step Decrement Seek Up Seek Down Source Pick Up Call/ Call History On/Off End Call / Deactivate VR Activate VR	Continuous VOL + Continuous VOL - None None None None None None None None

**VEHICLE APPLICATIONS:**

**LEXUS**

2004-2006 ES300  
 2003-2005 IS300

**TOYOTA**

2003-2019 4 Runner  
 2005-2018 Avalon  
 2007-2017 Camry  
 2004-2008 Camry Solara  
 2009-2017 Corolla  
 2007-2014 FJ Cruiser  
 2008-2018 Highlander  
 2005-2012 Matrix  
 2004-2017 Prius  
 2004-2018 Rav4  
 2005-2018 Sequoia  
 2004-2016 Sienna  
 2005-2019 Tacoma  
 2004-2019 Tundra  
 2009-2015 Venza  
 2008-2011 Yaris

**NOTE:**

Does not retain Mark Levinson, Pioneer, Nakamichi or Harmon Kardon amplifiers.