

PRODUCT FEATURES:

- Retains factory features with an aftermarket radio.
- Retains factory-installed Subwoofer.
- Retains Steering Wheel Controls via built-in, pre-programmed interface
- With navigation outputs (Reverse gear, Illumination and Speed signal).
- Provides Accessory Power (2A MAX).

PARTS INCLUDED:



CAN SWC Module



Analog SWC Module



SWRFD-60 Harness



SWC Cables

INSTALLATION DIAGRAM:

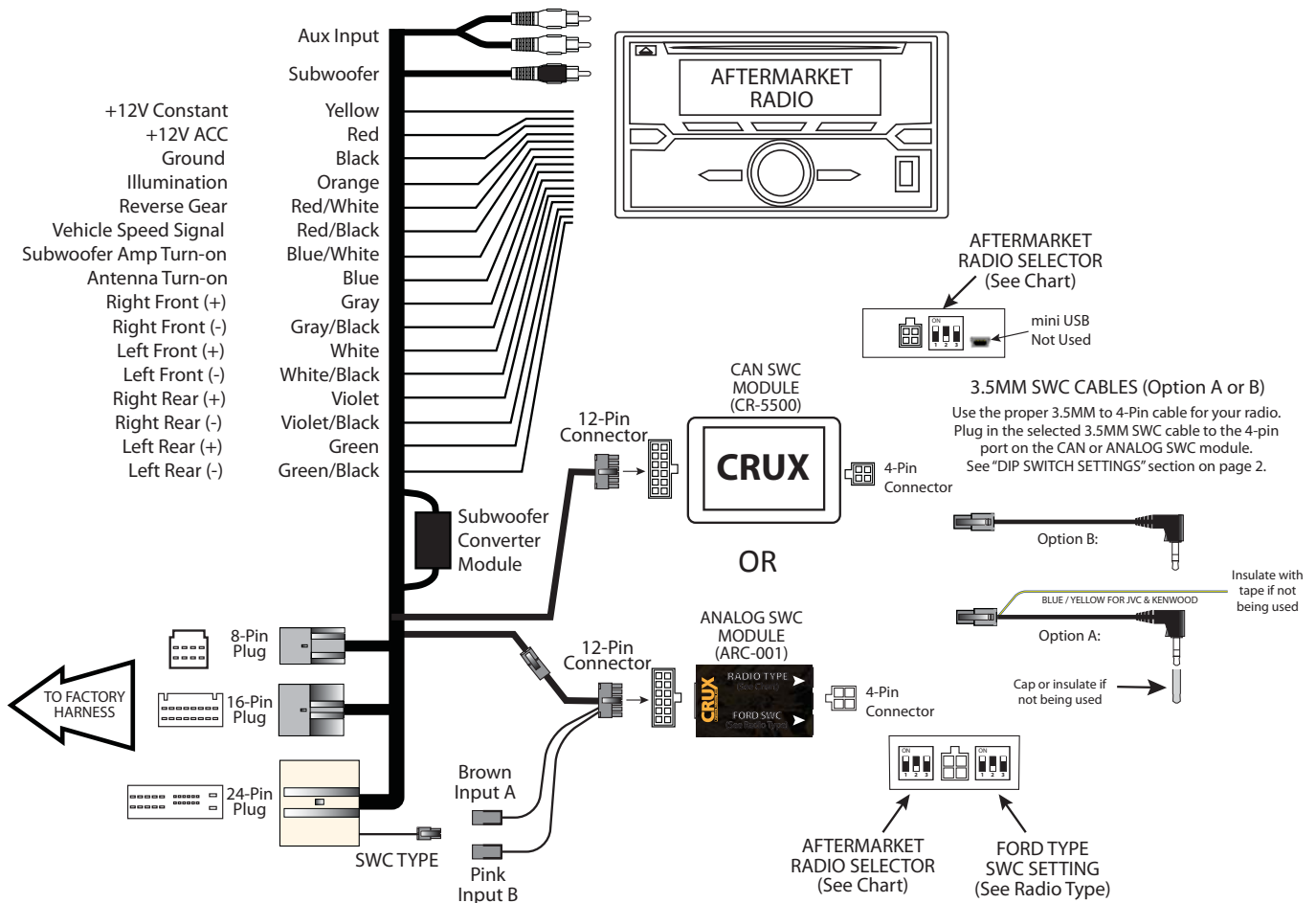

ANALOG CONNECTION:

HOW TO DETERMINE IF THE VEHICLE HAS ANALOG SWC

Analog Steering Wheel Control (SWC) signal, vehicles will have wires populated and line up to WHITE and BROWN wire on the 24-Pin Crux connector.

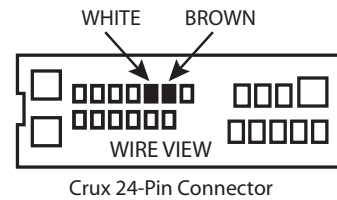

DIP SWITCH SETTINGS:

Once it is determined what type of SWC is on the vehicle (CAN or Analog), plug in the proper SWC cable for the radio that is being used to the CAN or Analog SWC module. Set the DIP switches following the chart below:

RADIO BRAND:	DIP:	1	2	3
Atoto, Blaupunkt, Dual, Fahrenheit		OFF	ON	ON
Jensen, Pioneer, Power Acoustik		OFF	ON	ON
Soundstream & most off-brand radios		OFF	ON	ON
Alpine		OFF	OFF	OFF
Clarion		ON	ON	OFF
Kenwood		ON	ON	ON
JVC		ON	OFF	ON
Sony, Boss		ON	OFF	OFF

CAN SWC AFTERMARKET RADIO SELECTOR	→	
ANALOG SWC AFTERMARKET RADIO SELECTOR	→	

NOTE: For Atoto, Blaupunkt, Dual, Fahrenheit, Power Acoustik, Soundstream, and most off-brand radios, check the aftermarket radio's manual to see if the SWC buttons need to be programmed.

3.5MM SWC CABLE

Use the proper 3.5MM to 4-Pin SWC cable for the aftermarket radio you are using.

OPTION A is used for ALPINE, CLARION, (JVC and KENWOOD units will use the Blue/Yellow wire).

OPTION B is used for Atoto, BOSS, DUAL, FAHRENHEIT, JENSEN, POWER ACOUSTIK, PIONEER, SONY, SOUNDSTREAM and most off-brand radios.

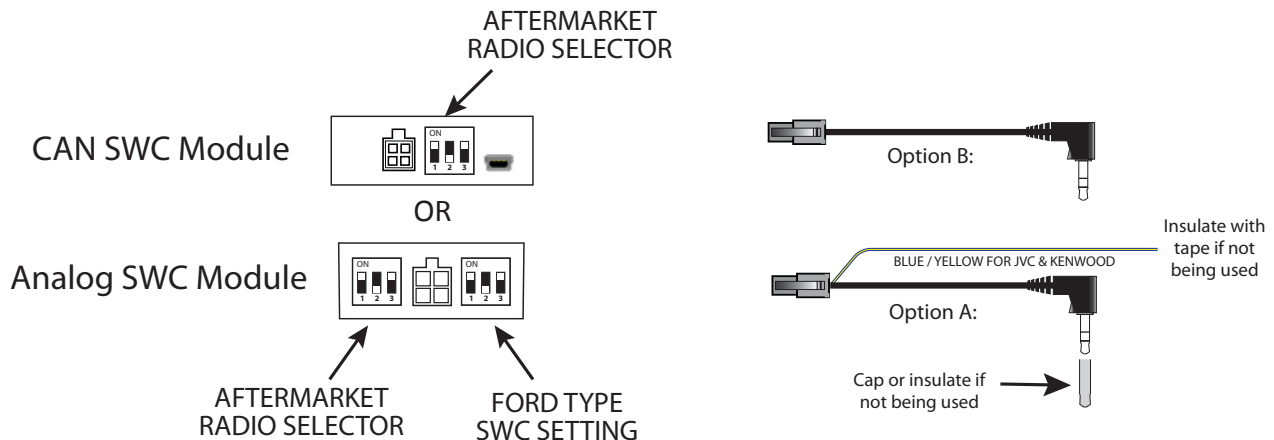

For aftermarket radios that have wires for SWC connections, cut off the 3.5mm plug on the Crux SWC Cable (option B) and connect the SWC wires as follows:

Note that there are some radios that only have SWC1 and SWC2, in this case “shield” does not need to be connected.



For Analog type SWC connect the BROWN or PINK wires with 2 pin Molex connector and set the Ford Type DIP switches following the diagram below:

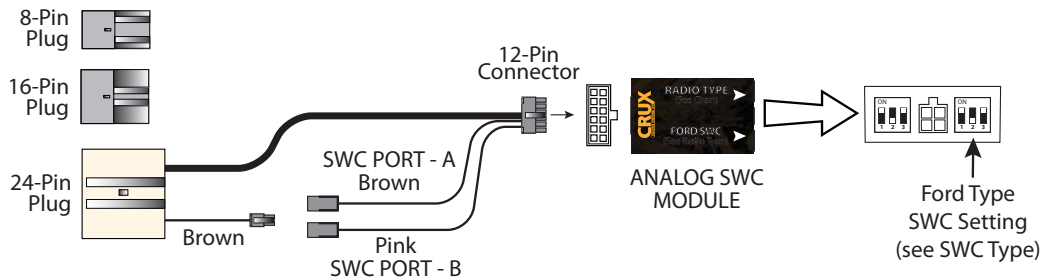

SWC TYPE:	DIP	1	2	3	
Ford Type 1: connect to SWC		OFF	OFF	OFF	- USING SWC PORT- A BROWN
Ford Type 2: connect to SWC		OFF	OFF	OFF	- USING SWC PORT- B PINK
Ford Type 3: connect to SWC		OFF	OFF	ON	- USING SWC PORT- A BROWN
Ford Type 4: connect to SWC		OFF	OFF	ON	- USING SWC PORT- B PINK

Approximate Year and SWC Type button:

- 1) Below 2007 Type 1 is supported: Vehicles with 4-Button: VOL+, VOL-, Next, Media
- 2) 2007-Up Type 2 is supported: Vehicles with 4-Button: Vol+, Vol-, Next, Mode
- 3) 2007-Up Type 3 is supported: Vehicles with 5-Button: Vol+, Vol-, Seek+, Seek-, Media
- 4) Below 2006 Type 4 is supported: Vehicles with 6-Button: Vol+, Vol-, Mem+, Mem-, Media, Mute

VEHICLE APPLICATIONS:

FORD

- 2007 – 2010 Edge
- 2008 – 2012 Escape
- 2007 – 2014 Expedition
- 2006 – 2010 Explorer
- 2007 – 2010 Explorer Sport Trac
- 2009 – 2014 F-150
- 2008 – 2012 F-250
- 2008 – 2012 F-350
- 2008 – 2012 F-450
- 2005 – 2007 Five Hundred
- 2009 – 2012 Flex
- 2008 – 2011 Focus
- 2005 – 2007 Freestyle
- 2006 – 2012 Fusion
- 2005 – 2013 Mustang
- 2008 – 2012 Taurus

LINCOLN

- 2009 – 2012 MKS
- 2007 – 2010 MKX
- 2007 – 2012 MKZ
- 2007 – 2014 Navigator
- 2006 – 2006 Zephyr

MERCURY

- 2007 – 2011 Mariner
- 2006 – 2011 Milan
- 2005 – 2007 Montego
- 2006 – 2010 Mountaineer

MAZDA

- 2009 – 2011 Tribute

NOTE: Does not retain Sync.