

PRODUCT FEATURES:

- Retains factory features in select Lexus and Toyota vehicles with JBL Harman-Becker Digital-Synthesis Amplifier, including JBL (Pioneer-made) amplifiers while functioning with an aftermarket radio.
- Variable audio gain adjustment to level match the aftermarket radio and factory amplifier.
- Retains OEM 3.5mm Auxiliary Audio Input.
- Retains factory backup camera (if equipped).
- EIA color coded wiring for easy installation.

NOTES:

1. Left-Right Balance Audio Control is supported. Front-Rear Audio Fading is not supported.
2. Please make sure the factory radio Balance and Fade options are centered before removing the radio.

PARTS INCLUDED:



SOHTL-20 Module



TY-A Harness
(For Newer Models)



TY-B Harness
(For Older Models)



OEM Camera Retention Harness



16 to 24 Pin Camera Adapter

IMPORTANT INSTALLATION NOTES:

1. In some Lexus/Toyota vehicles 2006 and older, the mute circuit is located in the same pin location as the amplifier turn-on on the OEM harness. If no audio is heard after the installation is complete, disconnect the BLUE/WHITE wire on the SOHTL-20 t-harness from the aftermarket radio AMP Turn-on wire. Insulate with tape to avoid short circuits.
2. To retain the factory AUXILIARY INPUT option in the vehicle, the aftermarket radio must have an "Auxiliary Audio Input" feature. Please check your aftermarket radio manual for details.

INSTALLATION DIAGRAM:

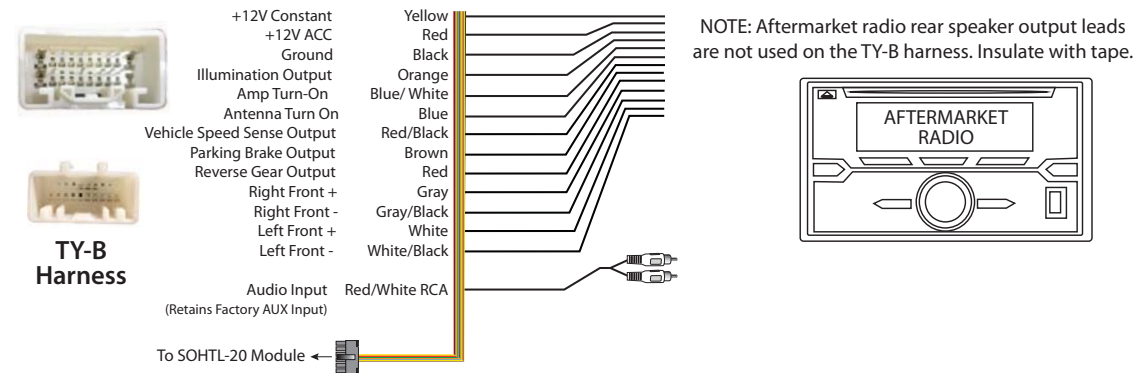
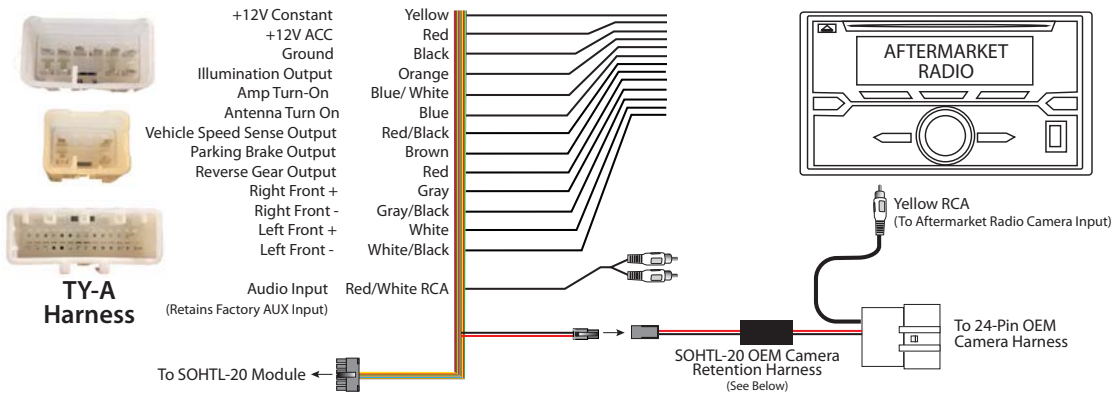

GAIN ADJUSTMENTS:

Use the gain adjustment to level match the aftermarket radio audio output with the OE amplifier input.

DIP SETTING	dB	Volts
OFF OFF OFF	0 dB	
OFF OFF ON	1.7 dB	+7mV
OFF ON OFF	3.5 dB	+9mV
OFF ON ON	5.2 dB	+10mV
ON OFF OFF	7.2 dB	+15mV
ON OFF ON	9.1 dB	+18mV
ON ON OFF	11 db	+22mV
ON ON ON	12.9 dB	+27mV

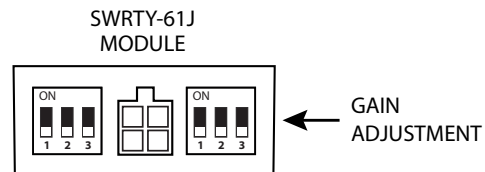

VEHICLE APPLICATIONS:

LEXUS

2004-2006	ES300
2003-2005	IS300
2006	LS430

TOYOTA

2003-2017	4 Runner
2005-2017	Avalon
2007-2017	Camry
2004-2008	Camry Solara
2009-2017	Corolla
2007-2014	FJ Cruiser
2008-2017	Highlander
2005-2012	Matrix
2004-2017	Prius
2004-2017	Rav4
2005-2017	Sequoia
2004-2016	Sienna
2005-2017	Tacoma
2004-2017	Tundra
2009-2015	Venza
2008-2011	Yaris

NOTE:

Does not retain Mark Levinson, Pioneer, Nakamichi or Harmon Kardon amplifiers.

PRODUCT FEATURES:

- Retains factory features in select Lexus, Scion and Toyota vehicles with JBL Harman-Becker Digital-Synthesis Amplifier, including JBL (Pioneer-made) amplifiers while functioning with an aftermarket radio.
- Variable audio gain adjustment to level match the aftermarket radio and factory amplifier.
- Retains OEM 3.5mm Auxiliary Audio Input.
- EIA color coded wiring for easy installation.

PARTS INCLUDED:



SOHTL-20 Interface Module



SOHTL-20 T-Harness (For Older Models)



SOHTL-20 T-Harness (For Newer Models)



OEM Camera Retention Harness

INSTALLATION DIAGRAM:

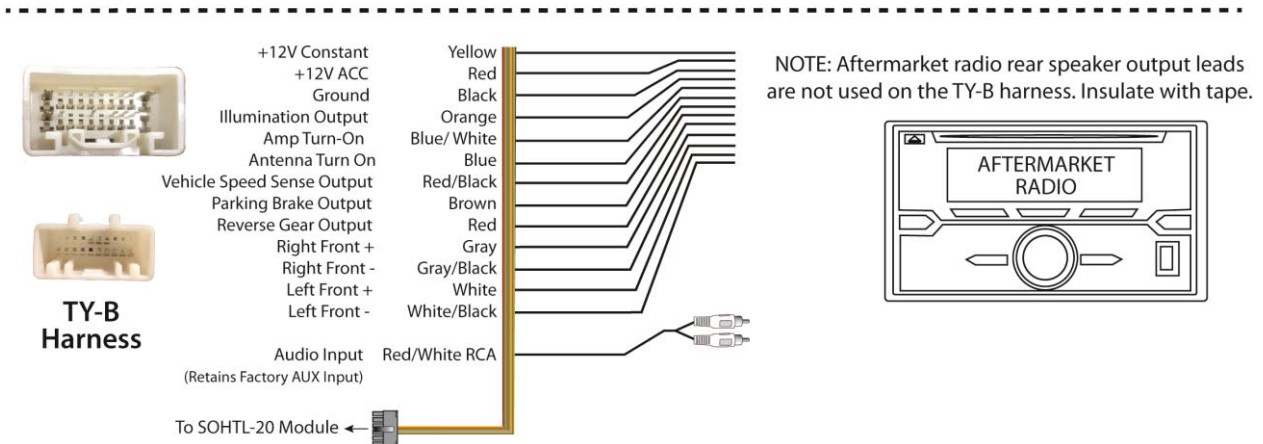
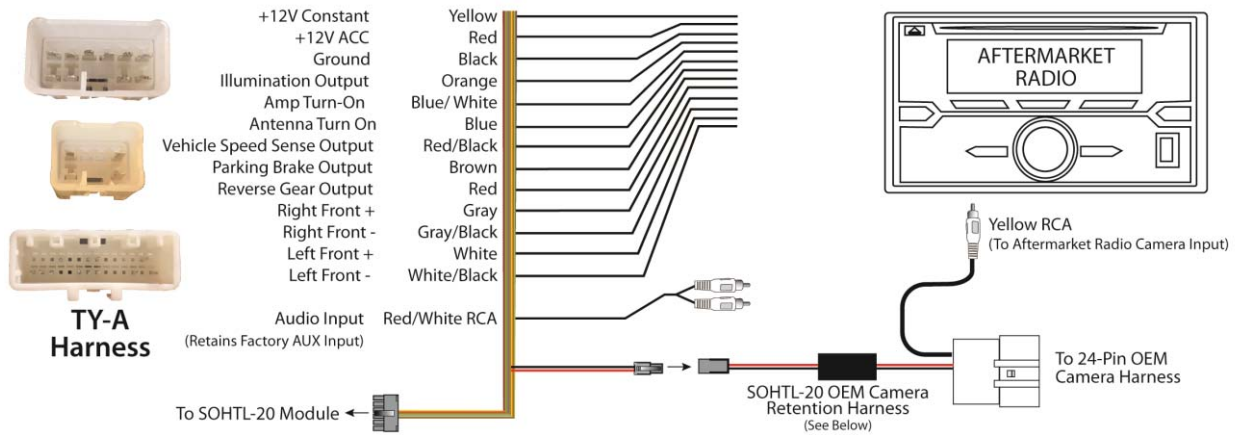

IMPORTANT INSTALLATION NOTES:

1. In some Lexus/Toyota vehicles 2006 and older, the mute circuit is located in the same pin location as the amplifier turn-on on the OEM harness. **If no audio is heard after the installation is complete, disconnect the BLUE/WHITE wire on the SOHTL-20 T-Harness from the aftermarket radio AMP Turn-on wire.** Insulate with tape to avoid short circuits.
2. To retain the factory AUXILIARY INPUT option in the vehicle, the aftermarket radio must have an "Auxiliary Audio Input" feature. Please check your aftermarket radio manual for details.

GAIN ADJUSTMENTS:

SOHTL-20 Module



DIP SETTING	dB	Volts
OFF OFF OFF	0 dB	
OFF OFF ON	1.7 dB	+7mV
OFF ON OFF	3.5 dB	+9mV
OFF ON ON	5.2 dB	+10mV
ON OFF OFF	7.2 dB	+15mV
ON OFF ON	9.1 dB	+18mV
ON ON OFF	11 dB	+22mV
ON ON ON	12.9 dB	+27mV

VEHICLE APPLICATIONS:

LEXUS

2004-2006	ES300
2003-2005	IS300
2004-2006	LS430

SCION

2013-2015	FRS
2016	iM
2012-2013	iQ
2005-2015	tC
2004-2007	xA
2004-2015	xB
208-2012	xC

TOYOTA

2003-2016	4 Runner
2005-2015	Avalon
2007-2016	Camry
2004-2008	Camry Solara
2009-2016	Corolla
2007-2014	FJ Cruiser
2008-2015	Highlander
2005-2012	Matrix
2004-2012	Prius
2004-2015	Rav4
2005-2016	Sequoia
2004-2016	Sienna
2005-2016	Tacoma
2004-2015	Tundra
2009-2015	Venza
2008-2011	Yaris