

**PRODUCT FEATURES:**

- Activates Mygig radio for enabling video features
- Tailgate handle camera included
- Interface includes Audio / Video Input to connect an extra A/V source
- Automatically switches to Rear-view when car is in Reverse mode
- Supports vehicles with manual transmission but does not supply +12V Reverse Trigger. Camera power must be tapped from the +12V reverse light wire instead
- Plug & Play Installation

**PARTS INCLUDED:**



RVCCH-75R Module



RVCCH-75R Harness



Tailgate Handle Camera

**INSTALLATION DIAGRAM:**

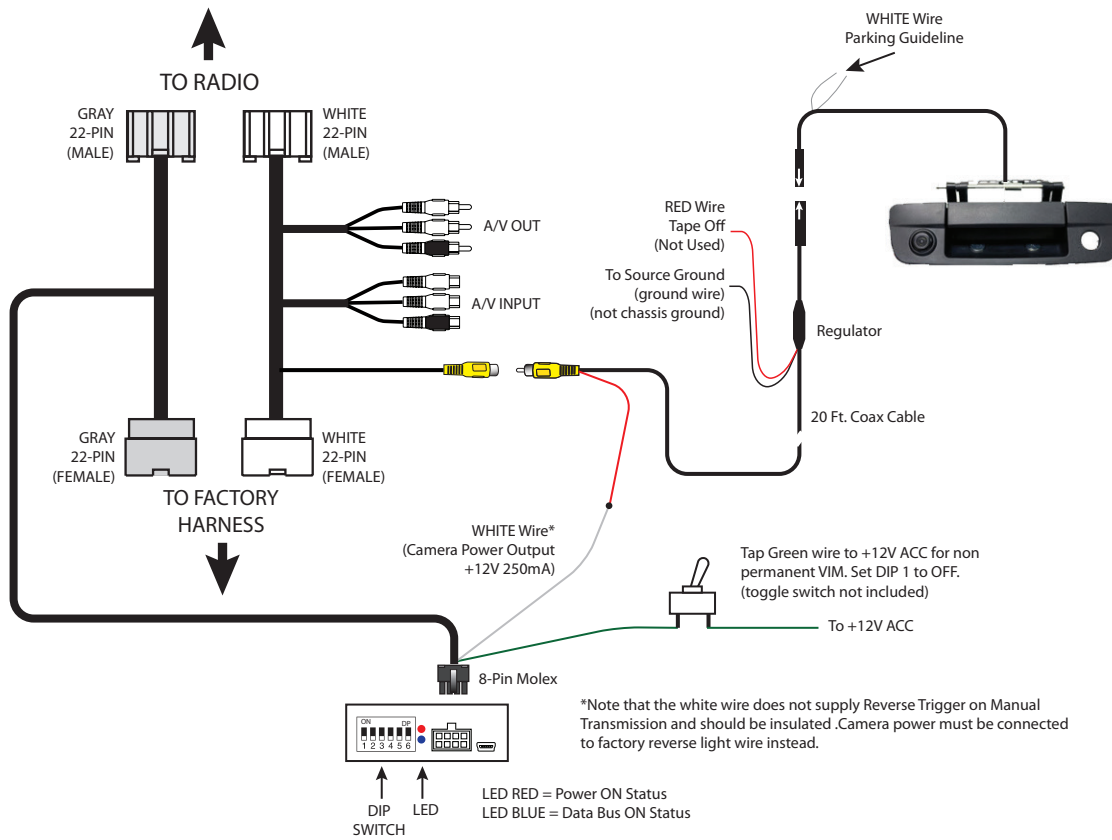

## DIP SWITCH SETTINGS:

### DIP SWITCH FUNCTIONS:

- DIP 1 = Video in Motion Activation ON (permanent VIM) / OFF (use Green wire)
- DIP 2 = Rear View Camera ON / OFF
- DIP 3 = Set to OFF
- DIP 4 = Set to OFF
- DIP 5 = CAN Termination Radio Side\*
- DIP 6 = CAN Termination Car Side\*

\*DIP 5 & 6

If the radio is having turn-on issues, please try the following:

Attempt 1: Set 5 & 6 to ON

Attempt 2: Set 5 to ON and 6 to OFF

Attempt 3: Set 5 to OFF and 6 to ON



## INSTALLATION INSTRUCTIONS:

### INSTALLING THE RVCCH-75R INTERFACE

1. Remove the factory radio to gain access to the factory connectors.
2. Plug in the t-harness with WHITE and GRAY connectors. (See wiring diagram on page 1)
3. Set the proper DIP Switch settings on the RVCCH-75R module. (See chart above)
4. Use the WHITE 12V Reverse Output wire to power the camera (see wiring diagram on page 1). **DO NOT connect the red power wire, near the camera, to the reverse light and insulate this red wire to avoid from shorting.** If the vehicle has a manual transmission, the camera power must be tapped to the +12V reverse light wire instead. In this case the WHITE 12V Reverse Output wire is not used and should be insulated to avoid from shorting.
5. Plug in the AV source and test for functionality.
6. Proceed to installing the tailgate handle camera.

### INSTALLING THE CDR-02 CAMERA

1. Remove the OE tailgate handle.
2. Remove the OE lock cylinder and install in the CDR-02 camera housing.
3. Install the new tailgate handle and run the cables to the radio.
4. Remove the factory radio to gain access to the factory connectors.
5. Route the wires towards the radio and make the power and video connections. For powering up the camera, use the 12V OUTPUT (White Wire). (See Wiring Diagram on page 1)
6. Connect the camera ground wire to chassis ground. If video noise is present, we recommend grounding the camera directly to the BLACK wire on the RVCCH-75D T-harness.
7. The CDR-02 has a built-in parking guide lines option and is defaulted to ON from the factory. To turn OFF the parking guide lines, cut the thin WHITE wire located on the camera cable 4 feet from the camera. Unplug the barrel connectors on the cable for 5 seconds. Align the arrows on the barrel connectors and firmly plug them together.
8. Plug in the Yellow male RCA from the camera cable to the Yellow female RCA of the t-harness with white connectors.
9. Put the gear in reverse to test the camera before re-installing the radio.

## LED INFORMATION:

The RVCCH-75R module has 2 LEDs on the side of the Molex connector that confirms its functionality as follows:

RED LED: ON = Confirms Power

BLUE LED: PULSING = No BUS, Pending Data

OFF = Complete Power Down

SOLID = BUS Recognized

## PARKING GUIDE LINES:

The parking lines are there to assist you while reversing. To deactivate the parking lines simply cut the WHITE loop wire located near the 4 pin camera connector and cycle the camera power.

What the Lines mean:

Green Line: CLEAR

Yellow Line: GETTING CLOSE

Red Line: WARNING - VERY CLOSE

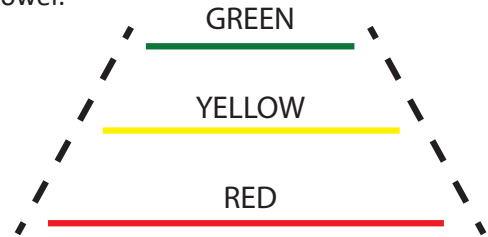

## SWITCHING SOURCES:

VES will be your source for the AV Input.



To access the VES button, press the RADIO/MEDIA button on the left side of the radio. The VES button is only active after the interface is properly installed.

## VEHICLE APPLICATIONS:

**RAM**

2009 - 2012 RAM Truck

## COMPATIBLE RADIO:

MyGig Radio

(HARD DISC DRIVE or HARD DRIVE printed on the lower right hand side of radio face)

