

PRODUCT FEATURES:

- Adds front and rear camera inputs.
- Front camera automatically shows on the screen after changing the gear from reverse to drive.
- Programmable from camera delay OFF time using the OSD menu.
- Plug and play installation.

PARTS INCLUDED:



RVCCH-75F Module



RVCCH-75F T-Harness



LVDS Cable



LVDS Video Extension Board

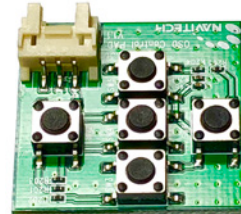

OSD Control Pad

WIRING DIAGRAM:

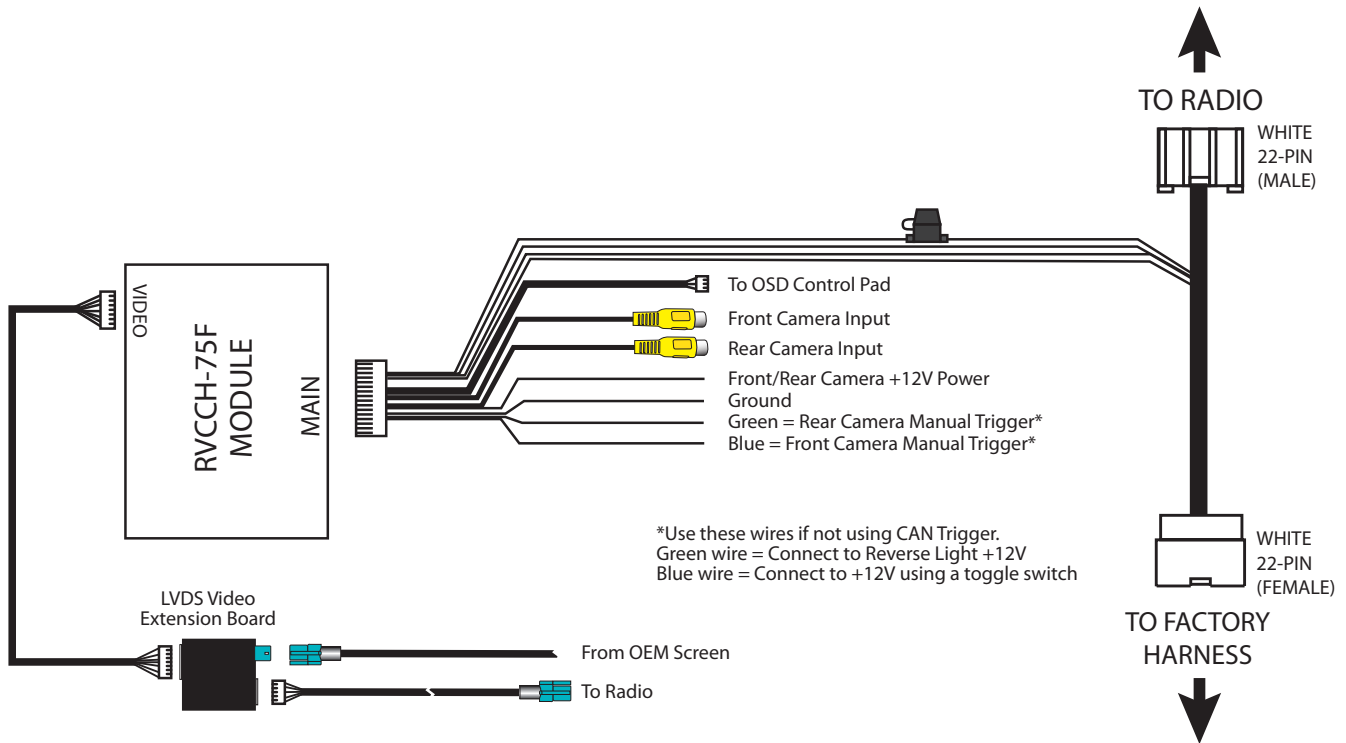

LVDS & MAIN HARNESS CONNECTION:

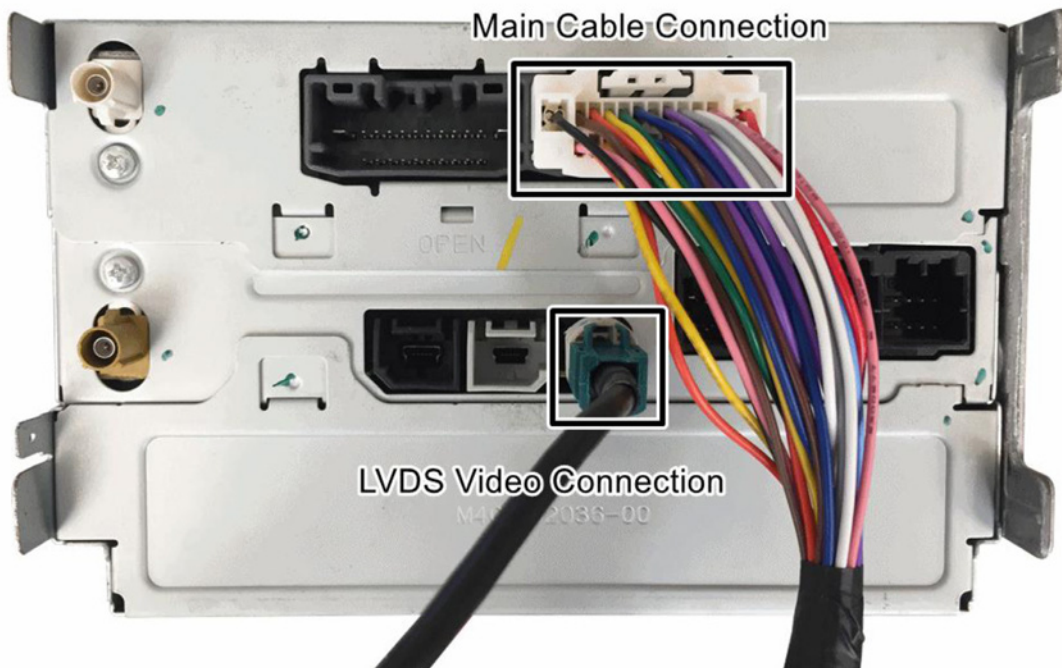

DIP SWITCH SETTINGS:



8.4" Screen



4" Screen

ON SCREEN DISPLAY (OSD) SETTINGS:

The OSD Setting Screen automatically pops up when the OSD Control Pad is connected.

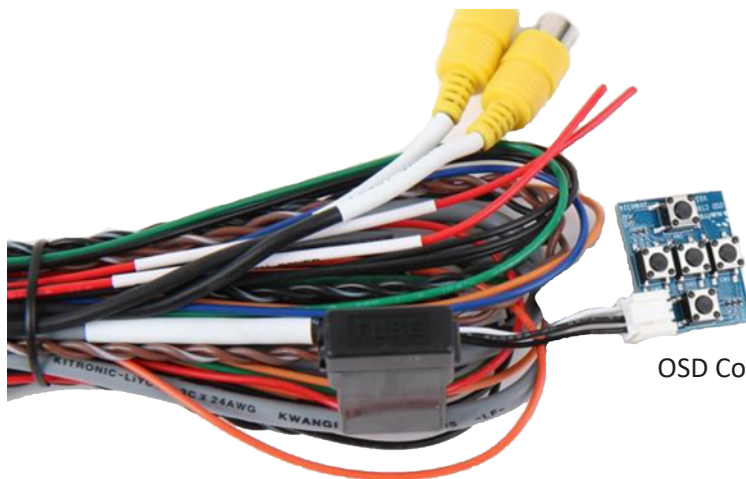

OSD Control Pad

Use the OSD menu to make the necessary settings. Remember to Run **Save&Reboot** after the settings are made. Unplug the OSD Control Pad after setting the cameras and keep it in a secure location in case it is needed to change the settings.

REAR AND FRONT CAMERA SETTING

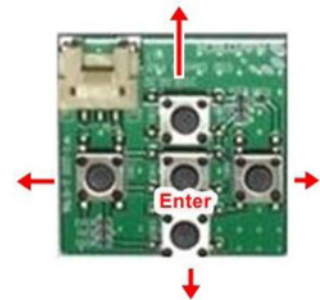
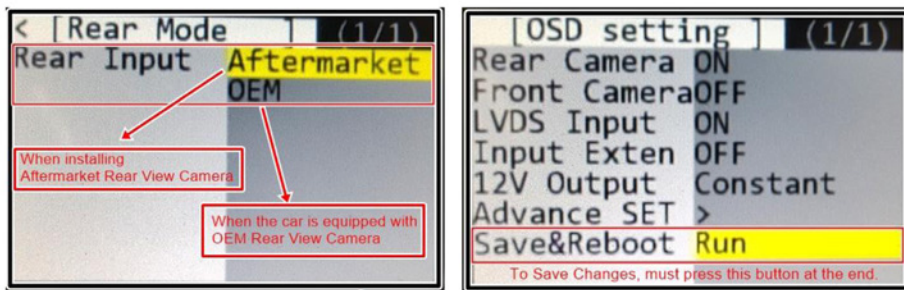
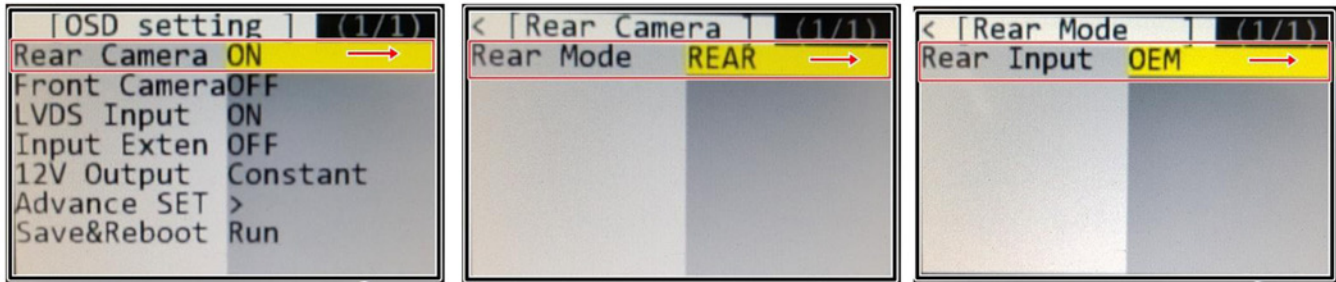

Dynamic Parking Guide Lines

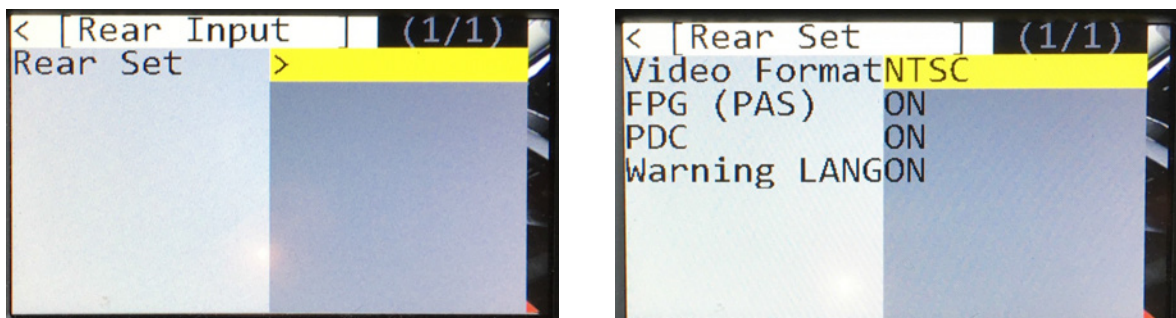

To turn ON the Dynamic Parking Guide Lines, go the Rear Input > Rear Set and turn ON Warning LANG. Go back to the root menu and Run Save&Reboot. Remember to unplug the OSD Control Pad otherwise the unit will not function properly. Set the parking brake on, start the car, put the gear in reverse, turn the steering wheel all the way to the left and all the way to right then put it in the center. The RVCCH-75F will calibrate automatically.

FRONT CAMERA SETTING

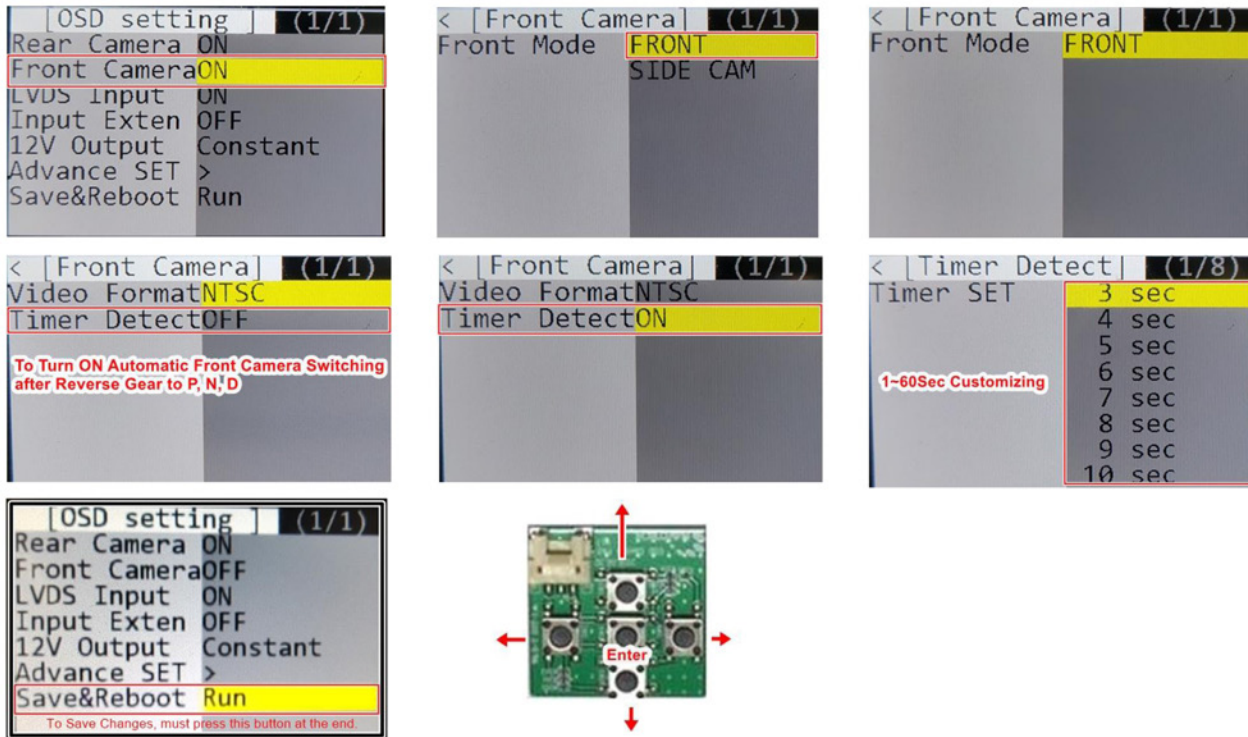

The front Camera will automatically show on the screen when the gear is put to Drive from Reverse. Set the delay time on the OSD menu. Delay time can be set from 1 to 60 seconds after a putting the car to drive from reverse.

VEHICLE APPLICATIONS:

Compatible with Uconnect Systems

CHRYSLER

2011 - 2014 300 (8.4" or 4.3" Screen)

DODGE

2011 - 2014 Charger (8.4" or 4.3" Screen)
2015 Challenger (8.4" or 4.3" Screen)
2011 - 2017 Journey (8.4" or 4.3" Screen)

FIAT

2011 - 2014 Freemont (4.3" Screen)

MASERATI

2014 - 2017 Ghibli (4.3" Screen)
2014 - 2017 Quattroporte (4.3" Screen)