



Tailgate Net

by **PRO NET™**

U.S. Patent # 4,763,944

Fig. 1

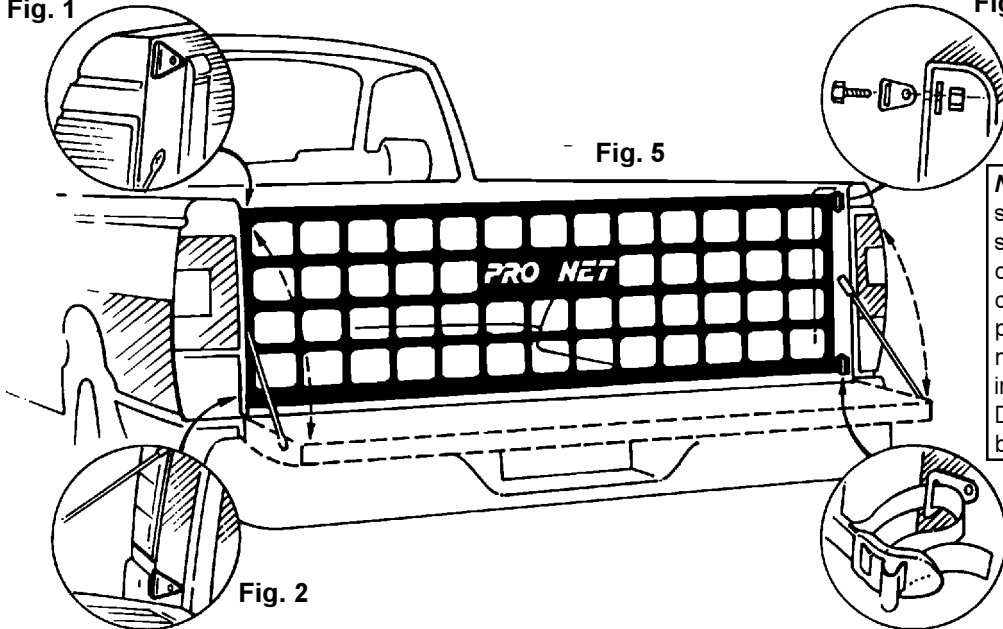

Fig. 3

Fig. 5

Fig. 2

NOTE - For 1997-on, FORD new body style pickups, install the net on the back side on the stake-bed housing (the side of the housing facing the rear of the cab). This is the only position that will provide proper clearance to tension the net. **Do not** use the large hole, already in the stake-bed housing, for mounting. Drill holes as noted in the instructions below.

Fig. 4

IMPORTANT NOTICE: *This product is not intended to restrain passengers or cargo.* The tailgate net is designed to work together with your original tailgate if needed. Tailgate nets are performance and appearance items which reduce aero-drag, minimize truckbed flexing, and improve rear visibility.

GENERAL INFORMATION: Your tailgate net is designed to mount just inside the tailgate - see Fig. 5. This feature allows for the convenient use of the tailgate to contain heavy cargo loads. Only four holes are required to mount your tailgate net's stainless steel hardware.

TOOLS REQUIRED: Drill with 1/4" bit and two 7/16" wrenches.

IN GENERAL: Take a few minutes to find the best location for each bracket. Have a friend help hold the net in position just inside the tailgate.

-- Every truck is slightly different. The mounting brackets are designed to mount in various positions to give even tension to the net when installed.

-- The upper brackets usually mount on the inside edge of the upper bed lip - see Fig. 1.

-- The lower brackets usually mount as low as possible into the back of the taillight housings.

STEP BY STEP INSTRUCTIONS:

1) **CAREFULLY** mark the bracket hole location onto the truck bed. It is often helpful to put tape under the mounting area during the marking and drilling process so that the locations can be easily marked and drilled without scratching the surrounding paint.

2) **REMOVE** both taillight assemblies if your vehicle's installation points enter the taillight housings.

3) **DRILL** the four 1/4" holes. If you have a center punch, it is a good idea to punch each hole location before drilling to help prevent the drill from skipping across the paint. Use two hands to steady the drill and proceed **slowly**.

4) **MOUNT** the four bracket assemblies. It is a good idea to apply a rust preventative to all four mounting holes. Be sure the washer is placed on the back side under the nut - see Fig. 3. **DO NOT OVERTIGHTEN THE MOUNTING BOLTS. A MAXIMUM OF 15 LBS TORQUE SHOULD BE APPLIED. OVERTIGHTENED BOLTS MAY BE WEAKENED.**

5) **REMOVE** all metal shavings from the truckbed and taillight housings.

6) **REPLACE** the taillight assemblies.

7) **INSTALL** your tailgate net. This tailgate net features a patented even tension design which eliminates flapping and flutter. **BE SURE TO INSTALL YOUR TAILGATE NET IN THE RIGHT PLACE.** Look at Fig. 1 to be sure you are threading the buckles correctly. The tailgate nets look and perform best when installed with about 15 to 30 pounds of pull on the webbing straps. When done correctly, your net should be perfectly flat and you should be able to "pluck" the upper and lower webbing edges like a guitar string.

MAINTENANCE: The tailgate net is made from a single piece of industrial quality vinyl-coated polyester fabric that is stretch-resistant, stainproof, colorfast and washes easily along with your truck. A soft cloth and mild detergent will keep it clean, and a good vinyl dressing will add protection and keep it looking great.

ACCESSORIES: **SPEED CLIPS** are super fast and convenient quick release stainless brackets that totally eliminate the need to thread and unthread the buckles each time you access the truck bed. **STRAP TRAPS** are custom designed, clip-on webbing strap retainers that neatly hold the four ends of the webbing straps to prevent them from flapping. If you are interested, contact your dealer or call Covercraft at 800 426-8333, Monday thru Friday from 8AM to 5PM CST.