



IMPORTANT WARRANTY & INSTALLATION
INSTRUCTIONS ATTACHED

*Please Forward All Attached Information to Consumer
Warranty Not Valid Unless Returned to CORSA Performance*



Please take time to read and understand these installation instructions.

CORSA recommends that the installation of this system be performed by a qualified service center or professional installer who has the necessary equipment, tools and experienced personnel. However, if you decide to perform this install the use of an additional person may be required.

CAUTION: Never work on a hot engine bay. Allow time for the vehicle to cool.

Recommended Tools:

- Flathead Screwdriver
- Assorted Socket-Set
- Ratchet
- Ratchet Extension

Please confirm that all parts are present according to the bill of materials before beginning the installation.

Bill of Materials					
1	CORSA Filter Box	1	4" x 3" Sleeve	1	1/2" NPT Straight Fittings
1	Filter Box Adapter (Preinstalled)	3	1/4" -20 Bolts	1	3/8" x 19" Breather Hose
1	CORSA Air Duct	6	1/4" Washers	1	MAF Sensor Gasket
1	PowerCore [®] Filter #61503 w/ Clamp	3	1/4" Lock Washers	2	SS 4 mm x 10 mm Bolts
4	#064 Clamps	1	1/4" Nut		
1	4" x 3" Hump Hose	2	1/4" -20 Nylon Lock Nuts		

PowerCore[®] is a registered tradename of Donaldson Company Inc.

SIDE VIEW

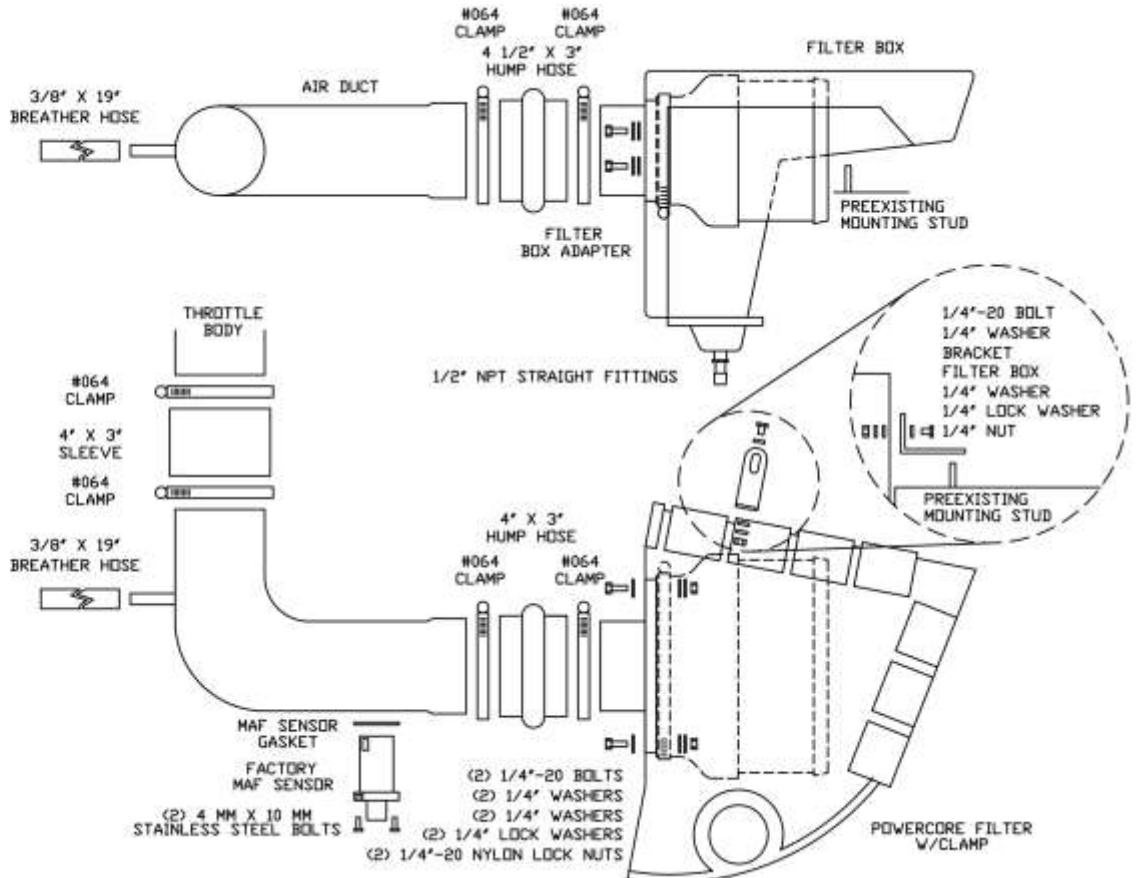

TOP VIEW

Installation Instructions:

Locate your vehicle's battery and disconnect the negative battery cable, this resets the computer and clears old air flow data to prevent CEL errors.

1. Remove the oil cap **(Fig A)**
2. Lift to remove the engine cover **(Fig B)**. **Save for reinstallation.** Reinstall oil cap after engine cover has been removed to prevent particulate from entering the engine during intake installation.
3. Pull the stock breather hose line from the stock air duct and unclip from the engine. **Save in case vehicle needs to be returned to stock. (Fig C)**
4. Carefully unplug the Mass Air Flow (MAF) sensor. **(Fig D)**
5. Loosen the clamps on the stock air duct, on the throttle body and the stock air box, using an 8mm socket. **(Fig E & F)**
6. Carefully remove the stock air duct from vehicle. **Save in case vehicle needs to be returned to stock. (Fig G)**
7. Pull up on the plastic clip located on the top drivers side or left stud. **(Fig H)**
8. Remove nut for each stud using a deep 10mm socket. **Save for reinstallation. (Fig I & J)**
9. Remove stock air box from vehicle. **Save in case vehicle needs to be returned to stock. (Fig K)**
10. Remove the grey bolt located in the front left corner of the engine bay using a 10mm wrench. **(Fig L)**
11. Remove MAF sensor from stock air box using a T20 Torx bit. **Save for reinstallation. (Fig M)**

WARNING: Over tightening hardware may alter the integrity of the CORSA air intake system.

12. Install the PowerCore[®] filter onto adaptor and tighten using an 8mm socket. **(Fig N & O)**
13. Install *(supplied)* bracket onto CORSA air box and tighten using a 7/16 socket and wrench. **(Fig P)**
14. Locate grommet in bottom of engine bay where stock air box was removed. Insert the CORSA air box into vehicle by pushing the fitting into the stock grommet. Make sure installed bracket *(from Step 13)* goes over the rear stud. Tighten bracket using the stock nut *(from Step 8)* using a deep 10mm socket. **(Fig Q & R)**
15. Install the MAF sensor into the CORSA air duct using *(supplied)* screws and gasket. **(Fig S)**

CONTINUED ON NEXT PAGE 

PowerCore[®] is a registered tradename of Donaldson Company Inc.

16. Install the CORSA hump hose with two (*supplied*) #64 clamps onto the CORSA air duct but do not tighten them. **(Fig T)**
17. Install the (*supplied*) 4" straight sleeve onto the throttle body with two (*supplied*) #64 clamps onto the throttle body but do not tighten them. **(Fig U)**
18. Insert the CORSA air duct into the installed straight sleeve on the throttle body. Tighten all clamps using an 8mm socket **(Fig V & W)**
19. Install the CORSA breather hose in the stock location (*from Step 3*) then push the other end onto the CORSA air duct. **(Fig X & Y)**
20. Plug the MAF sensor. **(Fig. Z)**
21. Remove the oil cap and reinstall the factory engine cover. **(Fig. AA)**
22. Reinstall the oil cap. **(Fig BB)**
23. **Reconnect** the battery cable.

***Check that this air intake complies with your Federal, State and Local laws. We recommend saving your factory system.**

BEFORE ROAD TESTING

1. Start engine, leaving the transmission in park and securing the parking brake.
 2. Make sure to look and listen for any unusual noises or air leaks. Repair problems if needed.
 3. Once completed it will be necessary to check periodically, after a few heat cycles, for realignment and tightening of all connections.
-

PICTURES ON NEXT PAGE 

Installation Pictures



Fig. A



Fig. B



Fig. C



Fig. D



Fig. E



Fig. F

CONTINUED ON NEXT PAGE



Installation Pictures



Fig. G



Fig. H



Fig. I



Fig. J



Fig. K



Fig. L

CONTINUED ON NEXT PAGE 

Installation Pictures



Fig. M



Fig. N



Fig. O

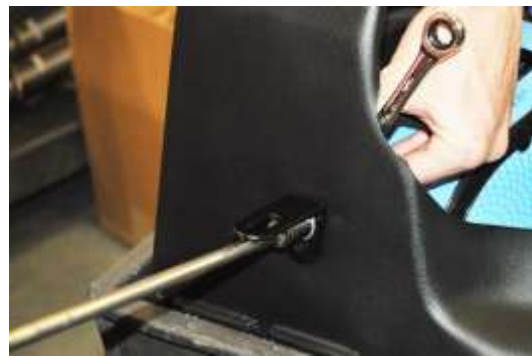

Fig. P



Fig. Q



Fig. R

CONTINUED ON NEXT PAGE 

Installation Pictures



Fig. S



Fig. T



Fig. U



Fig. V



Fig. W



Fig. X

CONTINUED ON NEXT PAGE 

Installation Pictures



Fig. Y



Fig. Z



Fig. AA



Fig. BB