

Please take time to read and understand these installation instructions.

CORSA recommends that the installation of this system be performed by a qualified service center or professional muffler installer who has the necessary equipment, tools and experienced personnel. However, if you decide to perform this install, the use of a hoist and an additional person will be required.

CAUTION: Never work on a hot exhaust system. Allow time for the vehicle to cool. Always wear eye protection when working under a vehicle.

Recommended Tools:

- 3/8" drive ratchet
- 3/8" drive long extension
- 3/8" drive swivel adapter
- 3/8" drive 13mm short socket
- 3/8" drive 15mm deep socket
- 1/4" drive ratchet
- 1/4" drive 8mm socket
- Grommet pullers
- Soap and water solution
- Torque Wrench
- Safety glasses

Please confirm that all parts are present before beginning the factory exhaust system removal and CORSA exhaust system installation.

Challenger

Xtreme

21068

21070(BLK)

Anti Seize
Lubricant

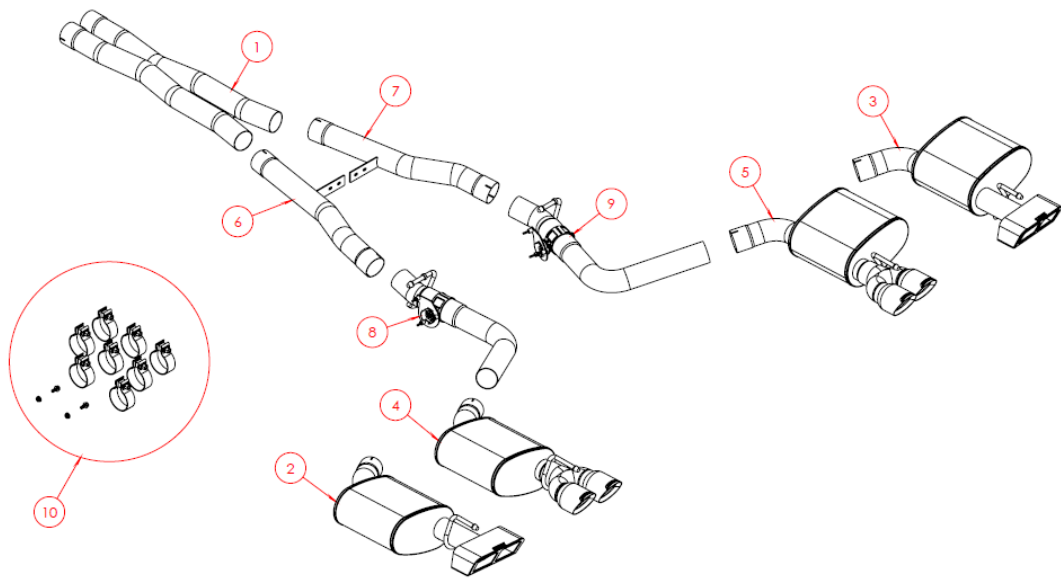

21068 Bill of Materials

2. 18LC2023 – REAR MUFFLER ASSEMBLY DRV (GTX2 TIPS)
3. 18LC2024 – REAR MUFFLER ASSEMBLY PASS (GTX2 TIPS)

21070(BLK) Bill of Materials

4. 18LC2041 – REAR MUFFLER ASSEMBLY DRV (ROUND TIPS)
5. 18LC2042 – REAR MUFFLER ASSEMBLY PASS (ROUND TIPS)

Shared Bill of Materials

1. 17CH4296 – X-PIPE ASSEMBLY CHALLENGER
6. 18LC4029 – TUNNEL PIPE ASSEMBLY DRV
7. 18LC4030 – TUNNEL PIPE ASSEMBLY PASS
8. 18LC4057 – VALVED AXLE PIPE ASSEMBLY DRV
9. 18LC4058 – VALVED AXLE PIPE ASSEMBLY PASS
10. 18LC7027 – HARDWARE KIT

Charger
Xtreme
21072(BLK)

Anti Seize
Lubricant 

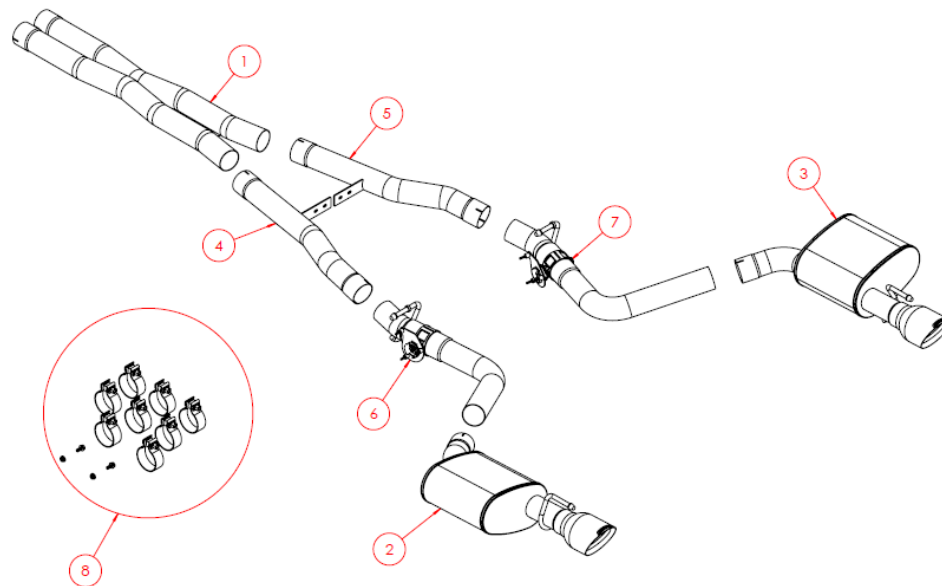

21072(BLK) Bill of Materials

- | | | | |
|----|---|----|---|
| 1. | 17CH4321 – X-PIPE ASSEMBLY CHARGER | 5. | 18LC4030 – TUNNEL PIPE ASSEMBLY PASS |
| 2. | 18LC2031 – REAR MUFFLER ASSEMBLY DRV (BLK) | 6. | 18LC4057 – VALVED AXLE PIPE ASSEMBLY DRV |
| 3. | 18LC2032 – REAR MUFFLER ASSEMBLY PASS (BLK) | 7. | 18LC4058 – VALVED AXLE PIPE ASSEMBLY PASS |
| 4. | 18LC4029 – TUNNEL PIPE ASSEMBLY DRV | 8. | 18LC7027 – HARDWARE KIT |

Factory Exhaust System Removal:

1. **Charger model ONLY** – Challenger model skip to step 2.
Using a 3/8" drive ratchet and a 13mm deep socket, remove the eight nuts holding up the front and rear chassis stiffening plates and remove the front and rear plates from the vehicle. **(Fig. A)**
2. Locate the driver and passenger side active valve modules located near the tunnel muffler exhaust hangers just in front of the rear differential. Disconnect both modules by pushing the tab on the top of the connector plugs and sliding the connector plugs upwards. **(Fig. B)**

NOTE: Do not start the vehicle or turn on the accessory power once the valves are unplugged, as this will trigger a check engine light.

3. Using grommet pullers or a similar device, remove the driver and passenger side tunnel muffler hangers from their corresponding hanger grommets. **(Fig. C)**

NOTE: The use of a soap and water solution may aid in the removal of hanger grommets.

4. Using a 3/8" drive ratchet and 15mm deep socket, loosen the driver and passenger side clamps at the cat-back connection point. **(Fig. D)**
5. Using a 3/8" ratchet, 13mm short socket, swivel adapter, and long extension, unbolt both the driver and passenger side front (if present) and rear hanger grommet assemblies from the vehicle chassis. Use jack stands

or a similar device to support the front and rear of the exhaust while unbolting the grommet assemblies. The exhaust is heavy and will no longer be supported once the grommet assemblies are unbolted. **(Fig. E & F)**

NOTE: Depending on your vehicle year, your stock system may not have front rear muffler hangers.

6. The stock exhaust can now be removed by sliding the system rearward to clear the overlapping pipe connection at the cat-back connection point; then lower the remaining portion of the stock exhaust system. **(Fig. G)**
7. Using grommet pullers or a similar device, remove the front (if present) and rear hanger grommet assemblies from the rear driver and passenger side mufflers. **(Fig. H & I)** Make note of the hanger grommet assemblies' orientation as they will be installed in the same position on the CORSA Performance exhaust system. Remove the ground wire from the rear passenger exhaust hanger. **(Fig. J)**
8. Remove the active valve modules from the stock exhaust using an 8mm socket and 1/4" ratchet. **(Fig. K)** Set aside the valve modules and the mounting hardware to be reused during the installation of the CORSA Performance exhaust system. This concludes the stock exhaust removal process.

REMOVAL PICTURES ON NEXT PAGE 

Factory Exhaust System Removal Pictures:



Fig. A



Fig. B



Fig. C



Fig. D



Fig. E



Fig. F

Factory Exhaust System Removal Pictures:



Fig. G

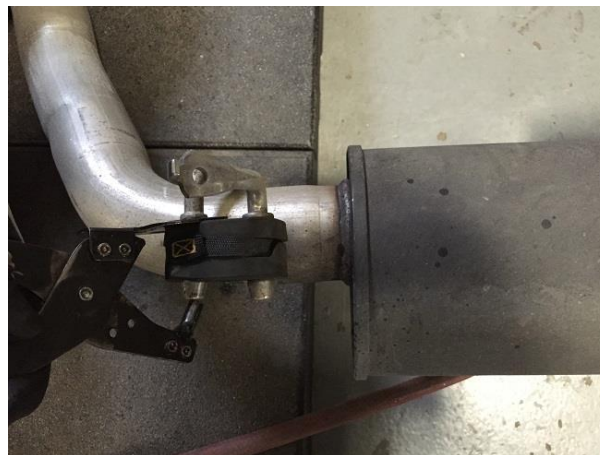

Fig. H



Fig. I

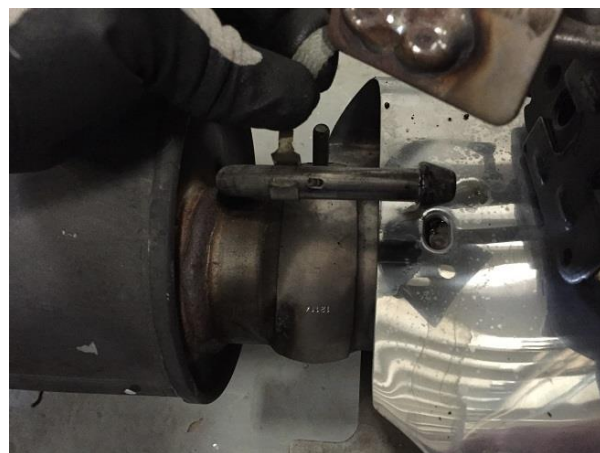

Fig. J

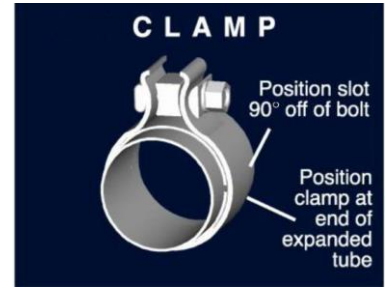

Fig. K

Installation of CORSA Exhaust System:

NOTE: Apply the anti-seize lubricant (supplied) to the threads **ONLY** of all the clamps and flange bolts. Failure to follow this procedure can cause nuts to seize on clamps and potentially destroy threads. After applying anti-seize lubricant, be sure to thoroughly clean your hands, as lubricant will tarnish stainless steel. All clamps should be tightened using a properly calibrated Torque Wrench. Using an air impact gun will damage the clamp and reduce its ability to effectively seal the joint. It may also cause the joint to separate, thereby causing damage to your exhaust system and to your vehicle.

NOTE: Align all clamps so that the center of the clamp bolt is 90 degrees from the notch in the pipe. (See Fig. CLAMP)



1. Remove all exhaust system components from the shipping boxes, including clamps and hardware.
2. Locate the x-pipe assembly and two 2.75" clamps. Install the clamps on the expanded inlet side of the x-pipe assembly so that the bolts are horizontal with the nuts towards the outside of the vehicle, with the x-pipe cross braces towards the bottom, slide the assembly over the stock exhaust pipes at the cat-back connection point. **(Fig. L)** Position the x-pipe assembly so that it is parallel with the ground and centered in the tunnel cavity; snug the clamps using a 15mm deep socket and ratchet. **(Fig. M)**
3. Next, locate the driver side tunnel muffler assembly and one 2.75" clamp. Install the clamp on the expanded inlet side of the tunnel muffler assembly as shown in Fig. P. Slide the tunnel muffler assembly over the driver side x-pipe outlet. **(Fig. N)** Position the brace so that it is parallel with the ground. After the driver side tunnel muffler has been installed, locate the passenger side tunnel muffler assembly and one 2.75" clamp. Install the clamp on the expanded inlet side of the tunnel muffler assembly as shown in Fig. P. Slide the tunnel muffler assembly over the passenger side x-pipe outlet with the brace parallel with the ground. **(Fig. O)**

NOTE: It's important to install the driver side tunnel muffler assembly first as the brace is offset further forward than on the passenger side to compensate for overlap.

NOTE: The driver and passenger side clamps will touch when not tightened. The clamps will pull in as they are tightened creating adequate clearance. **(Fig. Q)**

4. Locate the stainless steel nuts and bolts in the hardware kit. Install and snug one of the two bolts through the slotted hole in the brace. With the second slot exposed, position the two braces so that the slots are aligned and tighten the nut and bolt. **(Fig. P)** Insert the second nut and bolt through the open slot and tighten the fasteners to 15 Ft-lbs. With the braces aligned and the bolts tightened, snug the clamps at the driver and passenger side tunnel muffler inlet connection points. **(Fig. Q)**

INSTALLATION INSTRUCTIONS CONTINUED ON NEXT PAGE



5. Locate the passenger side valved axle pipe assembly, and the valve module and mounting hardware set aside in step 8 of the removal process. Align the valve module with the mounting studs on the valve assembly as shown. **(Fig. R)**

IMPORTANT NOTE: Rotate the actuator bracket at the top of the valve assembly until the slots in the bracket align with the spring on the valve module as shown **(Fig. R)**, then seat the valve module against the valve assembly. Secure using an 8mm socket and ¼" ratchet. **(Fig. S)**

6. Repeat step 5 for the driver side valved axle pipe assembly.
7. Locate a 2.75" clamp. Install the clamp on the expanded outlet end of the passenger side tunnel pipe outlet. Position the clamp so that the bolt is vertical with the nut towards the ground and the bolt towards the inside of the vehicle. Next, insert the passenger side valved axle pipe hanger into the corresponding passenger side tunnel hanger grommet. **(Fig. T)** Then, slide the axle pipe assembly into the expanded end of the tunnel pipe outlet. **(Fig. U)** Rotate the axle pipe assembly so that the hanger is parallel with the ground and the hanger grommet is swung forward. Using a 15mm deep socket and ratchet, snug the clamp.

NOTE: The active valve module should be facing the center or driver side of the vehicle **(Fig. T)**

8. Locate a 2.75" clamp. Install the clamp on the expanded outlet end of the driver side tunnel pipe outlet. Position the clamp so that the bolt is vertical with the nut towards the ground and the bolt towards the inside of the vehicle. Next, insert the driver side valved axle pipe hanger into the corresponding driver side tunnel hanger grommet. Then, slide the axle pipe assembly into the expanded end of the tunnel pipe outlet. Rotate the axle pipe assembly so that the hanger is parallel with the ground and the hanger grommet is swung forward. Using a 15mm deep socket and ratchet, snug the clamp.

NOTE: The active valve module should be facing the outside or driver side of the vehicle.

9. Locate the passenger side rear muffler, a 2.75" clamp, the corresponding passenger hanger grommet assemblies removed from the stock exhaust removal process, and the two 13mm bolts for the hanger grommet assemblies. If present, install the front hanger grommet onto the front muffler hanger in the same position as removed from the stock exhaust. **(Fig. V)** Next, install the rear hanger grommet onto the rear muffler hanger, again, in the same position as removed from the stock exhaust. **(Fig. W, X)**
10. Install the clamp on the expanded end of the rear muffler inlet pipe. Position the clamp so that the bolt is vertical with the nut towards the ground and the bolt towards the front of the vehicle. Slide the expanded end of the muffler inlet pipe over the passenger side axle pipe. **(Fig. Y)** Using a 13mm short socket, swivel adapter, 3/8" drive extension, and ratchet install the front (if present) and rear hanger grommet assemblies reusing the stock bolts. **(Fig. Z & AA)**

INSTALLATION INSTRUCTIONS CONTINUED ON NEXT PAGE 

11. On the passenger side only, clip the ground wire from the hanger grommet assembly onto the rear muffler hanger. **(Fig. BB)** Using a 15mm deep socket and ratchet, snug the clamp. **(Fig. CC)**
12. Repeat step #12 for the driver side of the vehicle.
13. Connect both the passenger and driver side active valve modules.
14. **Charger model ONLY**
Locate the two chassis brackets and the hardware removed from step #1 of the stock exhaust removal process. Re-install the plates using a 3/8" drive ratchet and 13mm socket **(Fig. DD)** Torque to factory recommended value.
15. Check that the clearance to the suspension mounts are adequate on both sides. Make sure that the x-pipe is level and not rotated to one side, this will ease tip adjustment. Check clearance between the driver side axle pipe and the spare tire well.
16. Adjust the system accordingly, including the rear muffler depth and rotation, so that the exhaust tip outlets are centered in the bumper exhaust cutouts. **(Fig. EE or FF)** Check clearance between the system components and chassis. Confirm the passenger side axle pipe does not interfere with the heat insulated wires protruding from the spare tire well. At this time, tighten all clamps to 45ft-lbs using the torque wrench and 15mm socket. This concludes the CORSA Performance exhaust installation.

NOTE: Slightly loosening the rear muffler hanger assemblies from the vehicle chassis with allow side to side adjustment of the tips. Hold the tip centered in the valance cut out while a helper tightens the hanger grommet assemblies.

NOTE: During cold weather start-ups, you may experience an exhaust sound that is deeper and louder in tone than usual. This is temporary and will diminish to normal levels once your engine has reached its normal operating temperature.

NOTE: Immediately following the installation of your exhaust system, you may experience a trace of smoke after initial start-up. DO NOT be alarmed. The smoke is caused by the burning of a small amount of forming oil residue used in the manufacturing process.

INSTALLATION PICTURES ON NEXT PAGE



CORSA Installation Pictures



Fig. L



Fig. M



Fig. N



Fig. O



Fig. P



Fig. Q

CORSA Installation Pictures

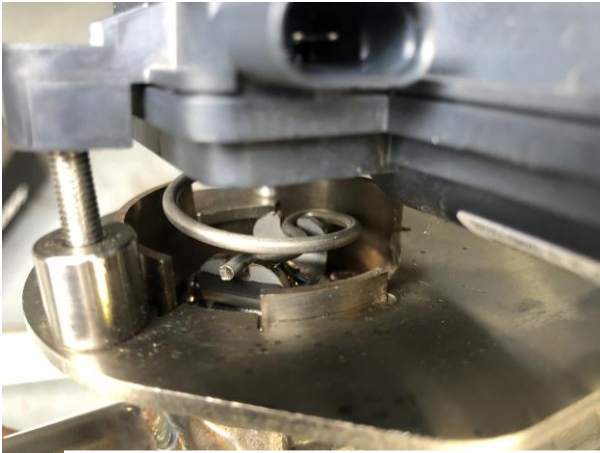

Fig. R



Fig. S



Fig. T



Fig. U



Fig. V



Fig. W

CORSA Installation Pictures



Fig. X



Fig. Y



Fig. Z



Fig. AA



Fig. BB



Fig. CC

CORSA Installation Pictures



Fig. DD



Fig. EE



Fig. FF