

15-18 FORD MUSTANG GT

CORSA[®]
PERFORMANCE



IMPORTANT! INSTALLATION INSTRUCTIONS

Please Forward All Information to Consumer

Be sure to review the enclosed instructions prior to beginning the installation process.



NEVER work on a hot exhaust system.
Allow time for the vehicle to cool.

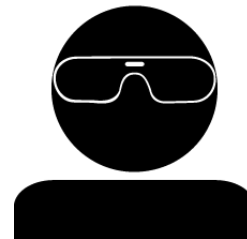

Always wear eye protection
when working under a vehicle.

INSTALL DIFFICULTY 

RECOMMENDED TOOLS & SUPPLIES

- 3/8" Drive Ratchet
 - 3/8" Drive 15mm Deep Socket
 - Torque Wrench
 - Short Extension (3")
-

2015-17: Fits Premium Package ONLY, Requires Roush Quad Tip Rear Valance Modification

2018+: Fits vehicles without Active Valves

Fits to CORSA Exhaust Systems ONLY

2015-2018 FORD MUSTANG GT 5.0L V8

Single 4.5" or Quad 4.0" Clamp on Tip Kit Assembly

Part #: 14333, 14333BLK, 14346, 14346BLK, 21038, 21038BLK



Please take time to read and understand these installation instructions.

CORSA recommends that the installation of this system be performed by a qualified service center or professional installer who has the necessary equipment, tools, and experienced personnel. However, if you decide to perform this installation yourself, the use of an additional person may be required.

WARNING: Never work on a hot exhaust system. Allow time for the vehicle to cool. Always wear eye protection when working under a vehicle.

CORSA Performance makes no representation or warranty, expressed or implied that its downpipe or header products and or components there-in comply with federal, state or local emission levels, noise levels, or safety standards or that any of their parts conform with the racing vehicles exemption, unless otherwise noted. The purchaser assumes all responsibility for such use and compliance.

This warranty does not extend to damaged or defect in the finish of a product or to any product, that in the opinion of CORSA Performance, has been misused, damaged by accident or negligence, altered or modified in any way, faulty installation or installed contrary to CORSA installation instructions, or repaired by an unauthorized service facility.

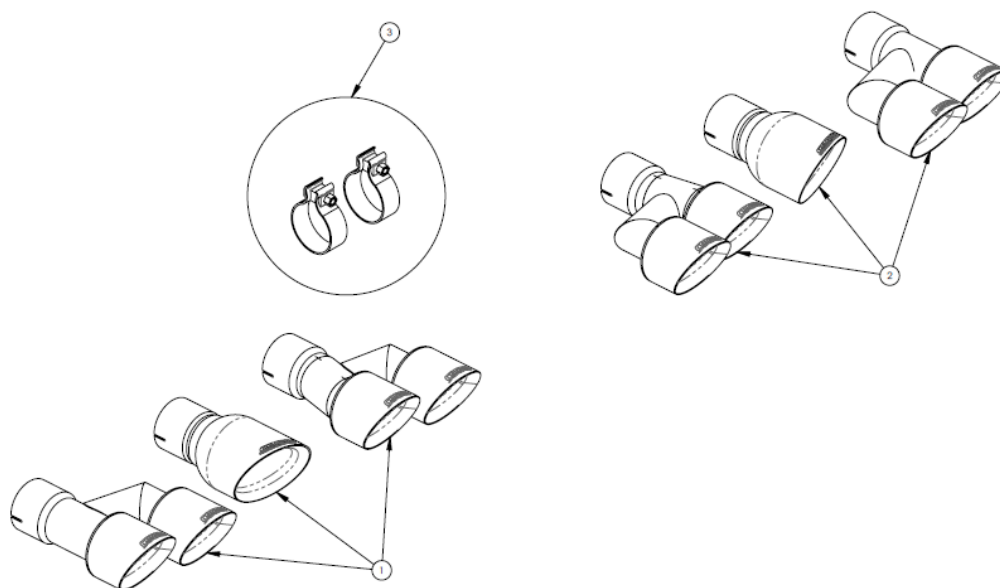

BILL OF MATERIALS

1.	15-17 Driver Single 4.5" Tip Assembly (20MU3010) 15-17 Roush Driver Quad 4.0" Tip Assembly (20MU3016) 18+ Driver Quad 4.0" Tip Assembly (20MU3022)	2.	15-17 Passenger Single 4.5" Tip Assembly (20MU3011) 15-17 Roush Passenger Quad 4.0" Tip Assembly (20MU3017) 18+ Passenger Quad 4.0" Tip Assembly (20MU3023)
3.	Hardware Kit (34GR7010)		

2015-17: Fits Premium Package ONLY, Requires Roush Quad Tip Rear Valance Modification

2018+: Fits vehicles without Active Valves

Fits to CORSA Exhaust Systems ONLY

2015-2018 FORD MUSTANG GT 5.0L V8

Single 4.5" or Quad 4.0" Clamp on Tip Kit Assembly

Part #: 14333, 14333BLK, 14346, 14346BLK, 21038, 21038BLK

CORSA[®]
PERFORMANCE

CAUTION: Never work on a hot exhaust system. Allow the vehicle to cool for at least an hour and a half. Always wear eye protection when working under a vehicle. It is recommended to use cotton gloves in order to protect stainless steel surface of the header from permanent grease and oil stains.

REMOVAL INSTRUCTIONS

FACTORY EXHAUST



1. Loosen the two clamp bolts at the inlet of the current CORSA driver and passenger tip assemblies using a 15mm socket and a 3/8" ratchet, and a short extension.



2. CAREFULLY remove the tip assembly from the mufflers to free it from the vehicle.
NOTE: Penetrating oil may help with removal process. Push up/down on the tip to open the notches, this will make it easier to remove the tip assembly.

3. Store the tip assembly in a safe location. CORSA recommends wrapping the tip assembly in foam or something soft and non-abrasive that will keep it from getting scratched or dented.

This concludes the removal of the factory exhaust.

WARNING! DO NOT SKIP THIS STEP!

Apply the anti-seize lubricant (*supplied*) to the threads **ONLY** of all the clamps and flange bolts. Failure to follow this procedure can cause nuts to seize on clamps and potentially destroy threads.

After applying anti-seize lubricant, be sure to **thoroughly** clean your hands, as lubricant will tarnish stainless steel.

All clamps should be tightened using a properly calibrated Torque Wrench. Using an air impact gun will damage the clamp and reduce its ability to effectively seal the joint. It may also cause the joint to separate, thereby causing damage to your exhaust system and to your vehicle.

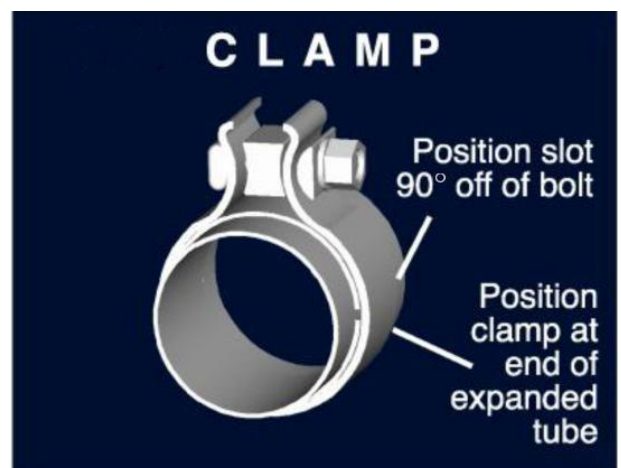

NOTE: Align all clamps so that the center of the clamp bolt is 90 degrees from the notch in the pipe.

2015-2018 FORD MUSTANG GT 5.0L V8

Single 4.5" or Quad 4.0" Clamp on Tip Kit Assembly

Part #: 14333, 14333BLK, 14346, 14346BLK, 21038, 21038BLK

CORSA[®]
PERFORMANCE

INSTALLATION INSTRUCTIONS

CORSA EXHAUST



1. CAREFULLY insert the tip assembly into the driver side muffler outlet pipe and snug the clamp using a 15mm socket, 3/8" driver ratchet and 3" extension.

2. Repeat on passenger side.



3. Adjust the position and depth of the tip assemblies until it is centered in the cutout, and has an equal amount of reveal on each side, then tighten the clamps using a 15mm socket and 3/8" ratchet. Torque the clamps to 45ft-lb using a torque wrench and 15mm socket, ensuring that the tips are still in the desired position.

NOTE: Depending on your current system alignment, small adjustments may need to be made at the x-pipe and rear muffler connection points to fully align and center the quad tip assemblies.

WARNING: DO NOT over-tighten the clamps on the tip assembly, as this will make future removal of the tip assembly much more difficult.

NOTE: During cold weather start-ups, you may experience an exhaust sound that is deeper and louder in tone than usual. This is temporary and will diminish to normal levels once your engine has reached its normal operating temperature.

NOTE: Immediately following the installation of your exhaust system, you may experience a trace of smoke after initial start-up. DO NOT be alarmed. The smoke is caused by the burning of a small amount of forming oil residue used in the manufacturing process.

NOTE: It is strongly suggested that all clamps be checked and tightened after road testing the vehicle once the system has cooled.