



IMPORTANT! INSTALLATION INSTRUCTIONS

Please Forward All Information to Consumer

Be sure to review the enclosed instructions prior to beginning the installation process.



NEVER work on a hot exhaust system.
Allow time for the vehicle to cool.

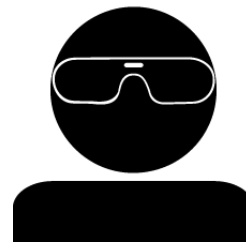

**Always wear eye protection
when working under a vehicle.**

INSTALL DIFFICULTY 

RECOMMENDED TOOLS & SUPPLIES

- 15mm Socket or Wrench
- 17mm Socket or Wrench
- Penetrating Lubricant Spray
- 3/8" Drive Torque Wrench
- 16mm Socket or Wrench
- Soap and Water Solution
- Grommet Puller or Similar Device
- 3/8" Drive Ratchet

Please take time to read and understand these installation instructions.

CORSA recommends that the installation of this system be performed by a qualified service center or professional installer who has the necessary equipment, tools, and experienced personnel. However, if you decide to perform this installation yourself, the use of an additional person may be required.

WARNING: Never work on a hot exhaust system. Allow time for the vehicle to cool. Always wear eye protection when working under a vehicle.

CORSA Performance makes no representation or warranty, expressed or implied that its downpipe or header products and or components there-in comply with federal, state or local emission levels, noise levels, or safety standards or that any of their parts conform with the racing vehicles exemption, unless otherwise noted. The purchaser assumes all responsibility for such use and compliance.

This warranty does not extend to damaged or defect in the finish of a product or to any product, that in the opinion of CORSA Performance, has been misused, damaged by accident or negligence, altered or modified in any way, faulty installation or installed contrary to CORSA installation instructions, or repaired by an unauthorized service facility.

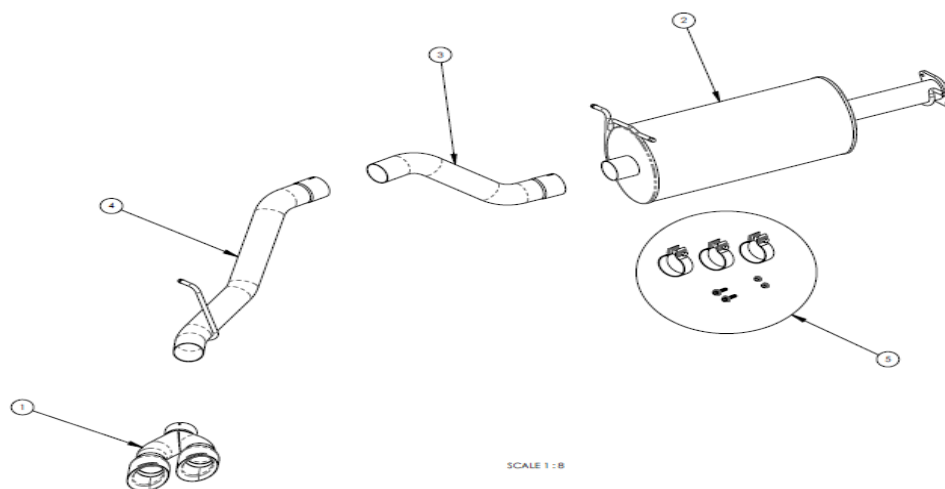

BILL OF MATERIALS

1.	16TA3000 (Tips)	2.	18DR2033 (Truck Muffler)
3.	18DR4161 (Front Tailpipe)	4.	18DR4162 (Rear Asm Tailpipe)
5.	18DR7071 (Hardware Kit)		

CAUTION: Never work on a hot exhaust system. Allow the vehicle to cool for at least an hour and a half. Always wear eye protection when working under a vehicle. It is recommended to use cotton gloves in order to protect stainless steel surfaces from permanent grease and oil stains.

REMOVAL INSTRUCTIONS

FACTORY EXHAUST

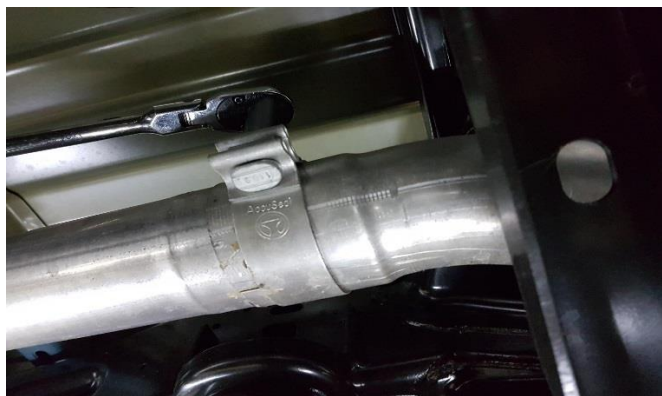

1. Loosen rear tailpipe clamp using a 15mm socket or wrench.



2. Remove rear tailpipe hanger using a Grommet Puller or Similar Device.

NOTE: The use of soap and water solution may aid in the removal and installation of hanger grommets.



3. Carefully remove the rear tailpipe from the vehicle and place it aside.

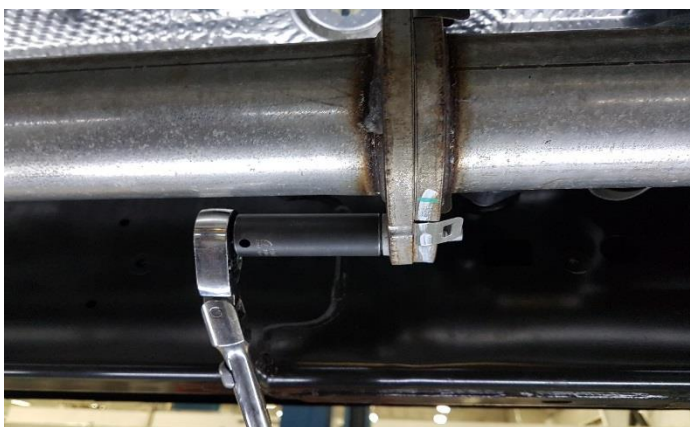

4. Loosen and remove the two muffer flange bolts that secure the muffer inlet flange using a 16mm socket or a wrench.

Continued on Next Page . . .

REMOVAL INSTRUCTIONS

FACTORY EXHAUST



- 5.** Remove both of the hangers from the grommets at the back of the muffer using a Grommet Puller or Similar Device.

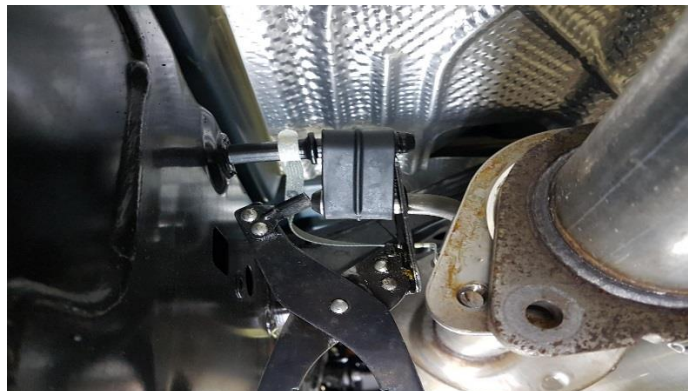

- 6.** Remove the hanger from the front of the muffer using a Grommet puller or similar device.



- 7.** Carefully guide the factory muffer and the front tailpipe assembly towards the front of the vehicle and down to remove the system completely from the vehicle.



- 8.** Remove the factory gasket from the muffer and save it to reuse it for the Corsa System.

Step 8 completes the factory removal of your system.

WARNING! DO NOT SKIP THIS STEP!

Apply the anti-seize lubricant (*supplied*) to the threads **ONLY** of all the clamps and flange bolts. Failure to follow this procedure can cause nuts to seize on clamps and potentially destroy threads.

After applying anti-seize lubricant, be sure to **thoroughly** clean your hands, as lubricant will tarnish stainless steel.

All clamps should be tightened using a properly calibrated Torque Wrench. Using an air impact gun will damage the clamp and reduce its ability to effectively seal the joint. It may also cause the joint to separate, thereby causing damage to your exhaust system and to your vehicle.

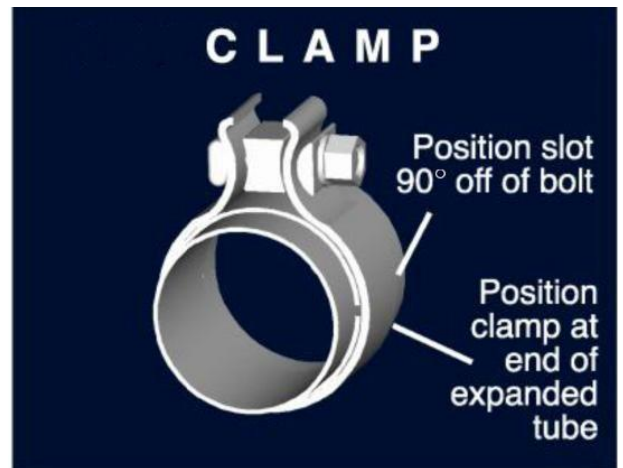

NOTE: Align all clamps so that the center of the clamp bolt is 90 degrees from the notch in the pipe.

INSTALLATION INSTRUCTIONS

CORSA EXHAUST



1. Place the gasket that was taken off from the factory exhaust system and place it on the mid pipe flange.



2. Line up the muffler as shown in the picture. Align the flange to the mating flange of the mid pipe.

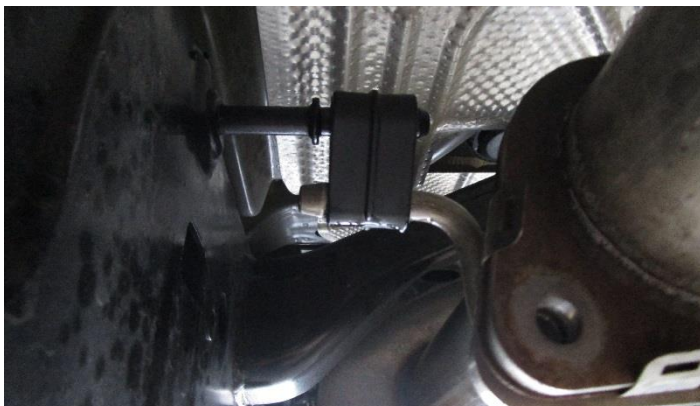

3. Place the front muffler hanger in the factory grommet.



4. Place the rear muffler hangers in the factory grommets.

Continued on Next Page . . .

INSTALLATION INSTRUCTIONS

CORSA EXHAUST



- 5.** Using a 17mm socket or wrench for the bolt, and a 15mm socket or wrench for the nut, secure the flange connection with the supplied hardware.

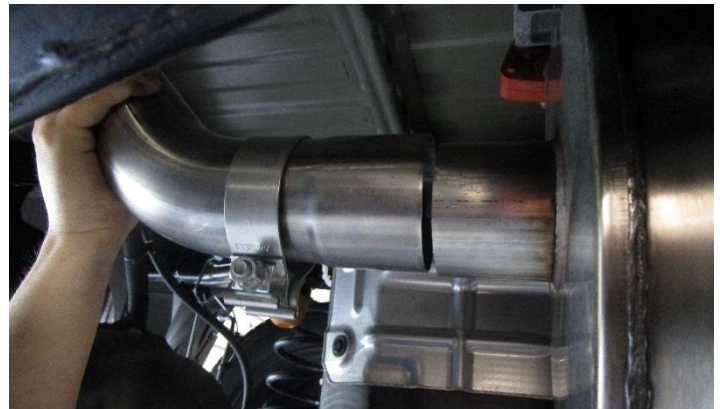

- 6.** Install a 3" clamp to the inlet of the front tailpipe as shown then insert the front tailpipe on the outlet of the muffler as shown.



- 7.** Secure the clamp using a 15mm socket or a wrench. **DO NOT** fully tighten at this time.



- 8.** Install a 3" clamp to the inlet of the rear tailpipe as shown then insert the rear tailpipe on the outlet of the front tailpipe as shown.



- 9.** Secure the clamp using a 15mm socket or a wrench. **DO NOT** fully tighten at this time.



- 10.** Insert the rear tailpipe hanger into the factory grommet.
NOTE: The use of soap and water solution will make installing hangers on the grommets easier.

Continued on Next Page . . .

INSTALLATION INSTRUCTIONS

CORSA EXHAUST

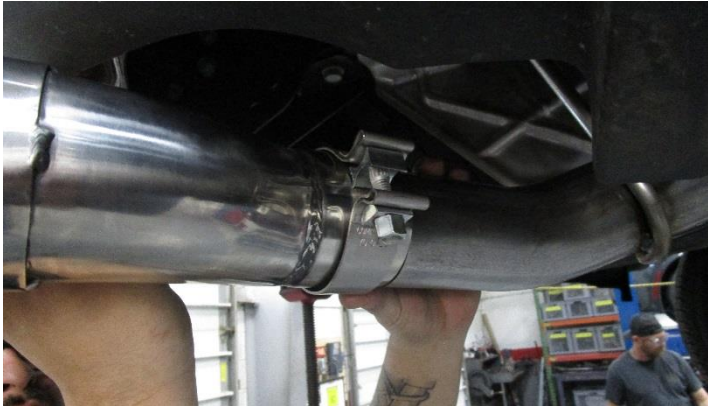

11. Place a 3" clamp into the inlet of the tip and install the tip into the rear tailpipe. Adjust the length and rotation of the tips per your preference.



12. Using a 15mm socket or a wrench, snug the tip clamp to leave room for adjustment.



13. Visually inspect the exhaust system for clearances, tip alignment, clamp orientation and position and make necessary adjustments at the flanges and the slip joints.

14. Starting at the front of the vehicle, tighten all the clamps to 45 ft/lbs and the flange hardware to 35 ft/lbs.

STEP 14 completes the installation of your Corsa Exhaust system.

NOTE: During cold weather start-ups, you may experience an exhaust sound that is deeper and louder in tone than usual. This is temporary and will diminish to normal levels once your engine has reached its normal operating temperature.

NOTE: Immediately following the installation of your exhaust system, you may experience a trace of smoke after initial start-up. DO NOT be alarmed. The smoke is caused by the burning of a small amount of forming oil residue used in the manufacturing process.

NOTE: It is strongly suggested that all clamps be checked and tightened after road testing the vehicle once the system has cooled.