

Please take time to read and understand these installation instructions.

CORSA recommends that the installation of this system be performed by a qualified service center or professional muffler installer who has the necessary equipment, tools and experienced personnel. However, if you decide to perform this install, the use of a hoist and an additional person will be required.

CAUTION: Never work on a hot exhaust system. Allow time for the vehicle to cool. Always wear eye protection when working under a vehicle.

Recommended Tools:

- 3/8" drive ratchet
- 3/8" drive torque wrench
- 3/8" drive 15mm deep socket
- Grommet pullers
- Chain cutter or similar device
- Deburring tool such as a file
- Ruler or tape measure
- Soap and water solution
- Safety glasses

Please confirm that all parts are present before beginning the factory exhaust system removal and CORSA exhaust system installation.

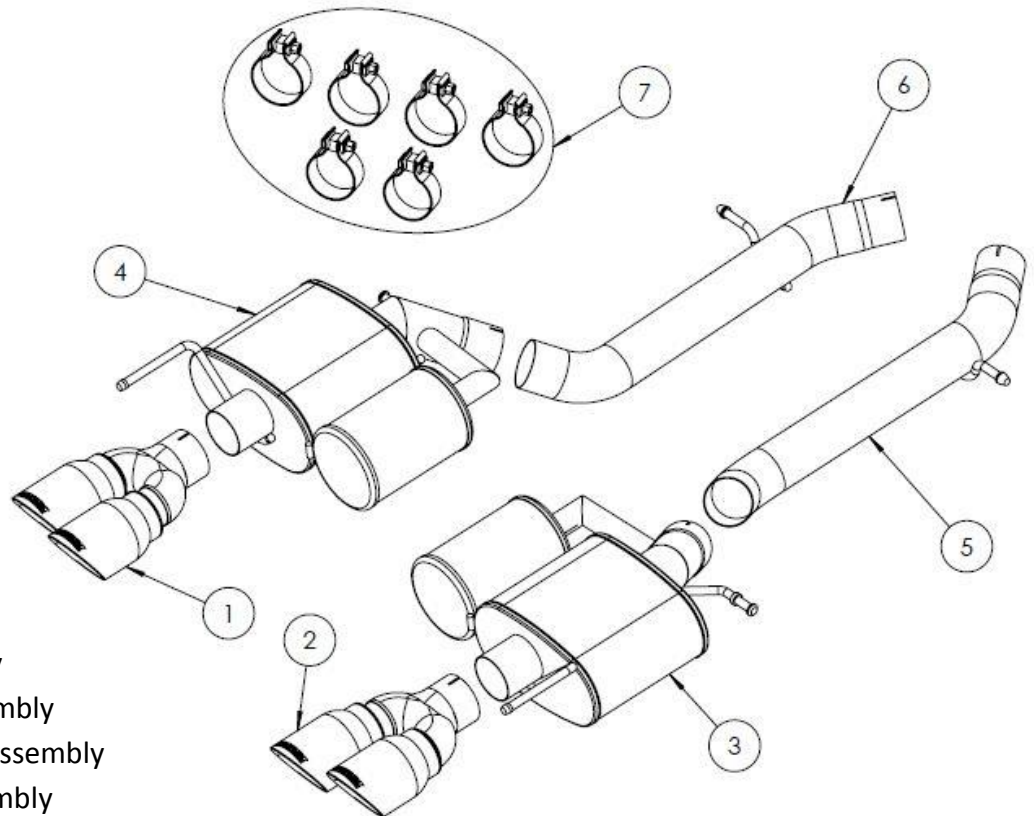

Bill of Materials

1. 13MV3007 – Driver tip assembly
2. 13MV3008 – Passenger tip assembly
3. 15AT2027 – Passenger muffler assembly
4. 15AT2028 – Driver muffler assembly
5. 15AT4053 – Passenger axle pipe assembly
6. 15AT4054 – Driver axle pipe assembly
7. 20MU7036 – Hardware kit

Factory Exhaust System Removal:

1. Begin at the rear of the vehicle near the exhaust tips. Gently open the grey retaining clip on the exhaust valve electrical connector – the clip slides back towards the wires. Remove the harness connector from the exhaust valve body. **(Fig. A & B)**
2. Locate the X crossover on the factory exhaust. To the rear of the X section, immediately after the first bend and on the driver's side of the vehicle, measure from the edge of the bend rearward 4.75" using a ruler or tape measure. **(Fig. C)** Compare the measurement to **(Fig. D)**, where the X crossover is toward the right of the picture. The line labeled "TANGENT" is the measurement start point at the end of the bend.
3. On the passenger's side of the vehicle, measure 2.50" rearward from the bend nearest the X crossover. **(Fig. E)** Compare your measurement to **(Fig. F)** where the left side of the image is the outlet of the X crossover.
4. Confirm all measurements – **measure twice, cut once!**
5. Using a chain style pipe cutter or similar device, cut the factory exhaust on the measured lines. Be careful as the cut ends of the pipe are sharp. Deburr or round the edges with a file or similar tool.
6. Using grommet pullers or a similar device, remove the front hangers. **(Fig. G)** Repeat for the middle hangers **(Fig. H)** just before the rear mufflers.
Note – Support the muffler inlet pipes with a jack stand or similar device as the only hangers supporting the muffler will be the rear hangers near the tips!
Note – Spraying a soap and water solution may aid in removal of hangers from rubber grommets.
7. Lower the front of the muffler slightly and gently tug toward the front of the vehicle to free the muffler from the rear-most hangers in the vehicle. Take care when removing the muffler as to not damage the rear hanger mounts, bumper, or cause personal injury as the muffler can be heavy and suddenly come free from the hangers. **(Fig. J)**
8. Remove the muffler assembly from beneath the vehicle. This concludes the factory exhaust removal.

REMOVAL PICTURES ON NEXT PAGE 

Factory Exhaust Removal Pictures:



Fig. A



Fig. B



Fig. C



Fig. D



Fig. E



Fig. F

REMOVAL PICTURES CONTINUED ON NEXT PAGE 

Factory Exhaust Removal Pictures Continued:



Fig. G



Fig. H

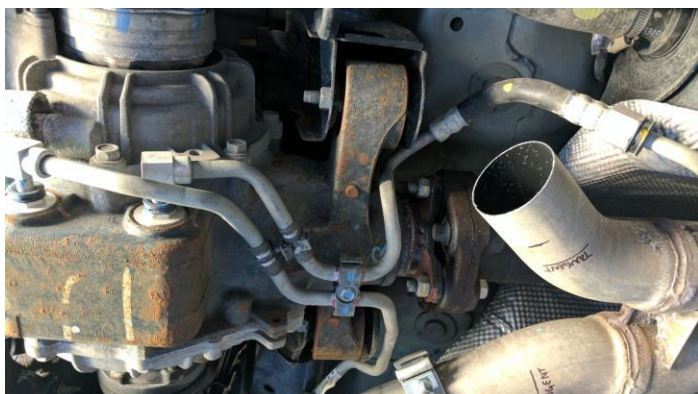

Fig. J

INSTALLATION CONTINUED ON NEXT PAGE



Installation of CORSA Exhaust System:

NOTE: Apply the anti-seize lubricant (supplied) to the threads **ONLY** of all the clamps and flange bolts. Failure to follow this procedure can cause nuts to seize on clamps and potentially destroy threads. After applying anti-seize lubricant, be sure to thoroughly clean your hands, as lubricant will tarnish stainless steel. All clamps should be tightened using a properly calibrated Torque Wrench. Using an air impact gun will damage the clamp and reduce its ability to effectively seal the joint. It may also cause the joint to separate, thereby causing damage to your exhaust system and to your vehicle.

NOTE: Align all clamps so that the center of the clamp bolt is 90 degrees from the notch in the pipe. (See Fig. CLAMP)

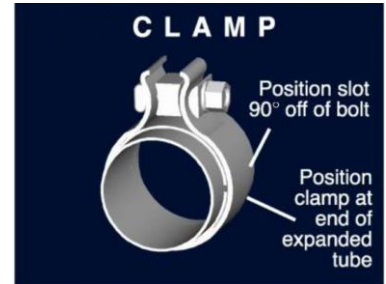

1. Remove all exhaust system components from the shipping boxes, including clamps and hardware.
2. Locate one of the 2.75" clamps and the passenger side axle pipe. Slip the clamp over the smaller end of the pipe. Orient the clamp such that the nut is toward the ground and the bolt is toward the inside of the vehicle. **(Fig. K)** Insert the hanger into the rubber grommet **(Fig. L)** followed by sliding the Corsa axle pipe over the cut end of the factory exhaust. **(Fig. M)** Using the 15mm deep socket and ratchet, snug the clamp only enough to hold it in place, but loose enough to allow adjustments later. **(Fig. N)**

Note: The use of a soap and water solution may aid in working with hangers and grommets.

3. Repeat Step #2 on the driver's side of the vehicle.
4. Locate one of the 3.00" clamps and the passenger's side rear muffler assembly. Slide the clamp onto the muffler as shown in **(Fig. P)**. Slide the rear hanger into the rubber grommet **(Fig. Q & R)** followed by the front hanger **(Fig. S & T)** before slipping the inlet onto the axle pipe **(Fig. U)**. Snug the clamp using the 15mm socket and ratchet just enough to hold it in place while still allowing adjustment. **(Fig. V)**
5. Repeat Step #4 on the driver's side of the vehicle.
6. Locate another 3.00" clamp and the passenger's side tip assembly. Slip the clamp over the inlet end with the bolt nearest the longer tip and as shown in **(Fig. W)**. Slide the assembly over the outlet of the muffler and snug with the 15mm socket and ratchet. Adjust depth and rotation of the tip assembly to position it within the valence cutout properly.
7. Repeat Step #6 on the driver's side of the vehicle.
8. Re-align the system as necessary. Refer to **(Fig. X & Y)** to ensure hangers are aligned properly in their grommets. They should be parallel to the ground. Check all clearances between exhaust, chassis, and suspension components. At this time, tighten all clamps to 45-ft-lbs using a torque wrench and 15mm socket. This concludes the installation of your CORSA Performance exhaust system.

INSTALLATION INSTRUCTIONS CONTINUED ON NEXT PAGE 

NOTE: During cold weather start-ups, you may experience an exhaust sound that is deeper and louder in tone than usual. This is temporary and will diminish to normal levels once your engine has reached its normal operating temperature.

NOTE: Immediately following the installation of your exhaust system, you may experience a trace of smoke after initial start-up. DO NOT be alarmed. The smoke is caused by the burning of a small amount of forming oil residue used in the manufacturing process.

INSTALLATION PICTURES ON NEXT PAGE 

CORSA Exhaust Installation Pictures:



Fig. K



Fig. L



Fig. M



Fig. N



Fig. P



Fig. Q

INSTALLATION PICTURES CONTINUED ON NEXT PAGE 

CORSA Exhaust Installation Pictures:

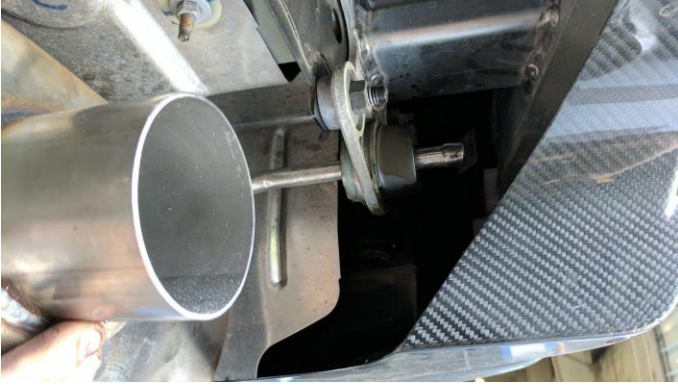

Fig. R



Fig. S



Fig. T



Fig. U



Fig. V



Fig. W

INSTALLATION PICTURES CONTINUED ON NEXT PAGE



CORSA Exhaust Installation Pictures:



Fig. X



Fig. Y