

Please take time to read and understand these installation instructions.

CORSA recommends that the installation of this system be performed by a qualified service center or professional muffler installer who has the necessary equipment, tools and experienced personnel. However, if you decide to perform this install, the use of a hoist and an additional person will be required.

CAUTION: Never work on a hot exhaust system. Allow time for the vehicle to cool. Always wear eye protection when working under a vehicle.

Recommended Tools:

- 3/8" drive ratchet
- 3/8" drive torque wrench
- 3/8" drive 13mm socket
- 3/8" drive 15mm deep socket
- 15mm wrench
- Grommet pullers
- Soap and water solution
- Penetrating lubricant spray
- Safety glasses

Please confirm that all parts are present before beginning the factory exhaust system removal and CORSA exhaust system installation.

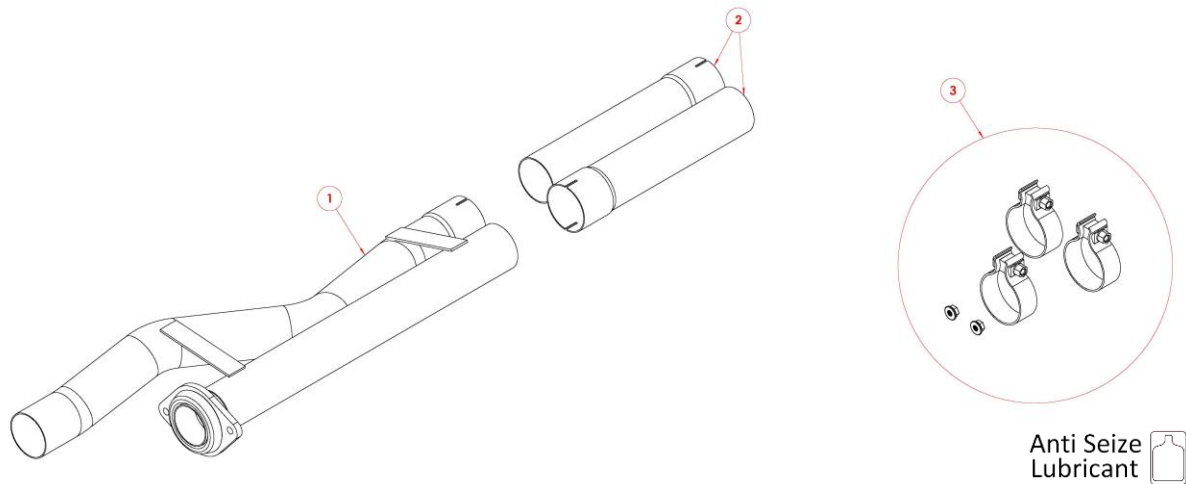

Bill of Materials

1. 20FF4170 – X-PIPE ASSEMBLY
2. 20FF4175 – X-PIPE EXTENSION PIPE (145" WB ONLY)
3. 20FF7076 – HARDWARE

Factory Exhaust System Removal:

1. Loosen the passenger side clamp and driver side sleeve clamp at the front resonator to Cat-Back exhaust connection points. **(Fig. A & B)** Using a flat head screw driver pry open the spring clip on the sleeve clamp up over the locating tab on the exhaust piping. **(Fig. C)** Slide the stock Cat-Back exhaust system rearward.

NOTE: If installing the CORSA Cat-Back exhaust system, follow the stock Cat-Back exhaust removal instructions provided with your CORSA exhaust system at this time.

NOTE: Spraying the exhaust hangers and hanger grommet with a soap and water solution may aid in sliding the exhaust system rearward.

2. Remove both bolts connecting the driver side downpipe flange to the resonator using a 13mm socket and ratchet. **(Fig. D)**
3. Loosen the down pipe to resonator passenger side sleeve clamp using a 15mm socket and ratchet. **(Fig. E)** Using a flat head screw driving pry up the spring clip on the sleeve clamp up over the locating tab on the resonator pipe.
4. The resonator is now free and can be removed from the vehicle. **(Fig. F)**

REMOVAL PICTURES ON NEXT PAGE



Factory Resonator Removal Pictures:

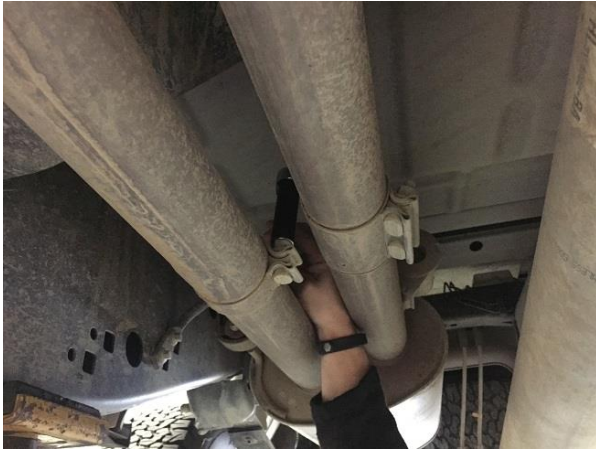

Fig. A



Fig. B



Fig. C



Fig. D



Fig. E

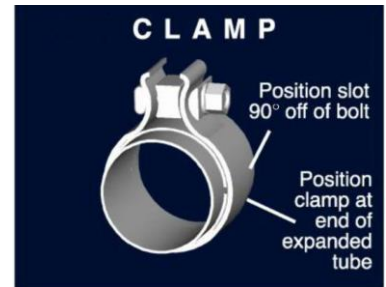

Fig. F

Installation of CORSA Exhaust System:

NOTE: Apply the anti-seize lubricant (supplied) to the threads **ONLY** of all the clamps and flange bolts. Failure to follow this procedure can cause nuts to seize on clamps and potentially destroy threads. After applying anti-seize lubricant, be sure to thoroughly clean your hands, as lubricant will tarnish stainless steel. All clamps should be tightened using a properly calibrated Torque Wrench. Using an air impact gun will damage the clamp and reduce its ability to effectively seal the joint. It may also cause the joint to separate, thereby causing damage to your exhaust system and to your vehicle.

NOTE: Align all clamps so that the center of the clamp bolt is 90 degrees from the notch in the pipe. (See Fig. CLAMP)



1. Remove all exhaust system components from the shipping boxes, including clamps and hardware.
2. Install the stock 2.5" sleeve clamp onto the passenger side inlet end of the X-Pipe assembly. Align the machined gasket of the X-pipe assembly to the factory flange on the vehicle along with the sleeve clamp and the passenger side downpipe outlet. **(Fig. G)** Slide the floating flange to the front of the assembly. Locate the bolts removed during step #2 of the factory resonator removal instructions along with the supplied 10mm nut. Using 13mm socket and ratchet along with a 15mm wrench, tighten the floating flange to the driver side downpipe flange. **(Fig. H)** Confirm the passenger sleeve clamp is located within the tab on the downpipe outlet and snug the sleeve clamp. **(Fig. I)**

145" WB only. 133" WB trucks continue to step #4.

3. Locate two 2 3/4" clamps along with the two extension pipes. Install one clamp on the expanded end of the X-pipe outlet so that the bolt is vertical with the nut towards the ground and the bolt is towards the outside of the vehicle. Slide the non-expanded end of the extension pipe into the expanded end of the X-pipe outlet and snug the clamp using a 15mm socket and ratchet. **(Fig. J)** Install the other clamp on the expanded end of the X-pipe extension pipe and slide the expanded end of the pipe over the non-expanded end of the X-pipe outlet. Position the clamp so that the bolt is vertical with the nut towards the ground and the bolt is towards the inside of the vehicle. Snug the clamp using a 15mm socket and ratchet. **(Fig. K)**

INSTALLATION INSTRUCTIONS CONTINUED ON NEXT PAGE



4. Locate the remaining 2 ¾" clamp. Install the clamp on the expanded passenger X-pipe outlet pipe so that the bolt is vertical with the nut towards the ground and the bolt facing the outside of the vehicle. Slide the stock sleeve clamp over the non-expanded outlet end of the X-pipe outlet on the driver side. (Fig. L)

If installing the CORSA performance Cat-Back exhaust, follow the CORSA installation instructions provided with your Cat-Back exhaust system. If re-installing the stock Cat-Back system proceed to step #5.

5. Slide the stock Cat-Back exhaust system forward while aligning the stock sleeve clamp between the X-pipe outlet and the driver side muffler inlet pipe; and the passenger side muffler inlet pipe with the expanded X-pipe outlet. Using a 15mm deep socket and ratchet, snug the sleeve clamp on the driver side and the 2 ¾" clamp on the passenger side.
6. Re-align the system as necessary. Check all clearances between exhaust, chassis, and suspension components. Confirm all hangers are properly fitted to their corresponding hanger grommets. At this time, tighten all clamps to 45-ft-lbs using a torque wrench and 15mm socket. This concludes the installation of your CORSA Performance resonator delete system.

NOTE: During cold weather start-ups, you may experience an exhaust sound that is deeper and louder in tone than usual. This is temporary and will diminish to normal levels once your engine has reached its normal operating temperature.

NOTE: Immediately following the installation of your exhaust system, you may experience a trace of smoke after initial start-up. DO NOT be alarmed. The smoke is caused by the burning of a small amount of forming oil residue used in the manufacturing process.

INSTALLATION PICTURES ON NEXT PAGE 

CORSA Installation Pictures



Fig. G



Fig. H



Fig. I



Fig. J



Fig. K



Fig. L