



IMPORTANT WARRANTY & INSTALLATION
INSTRUCTIONS ATTACHED

*Please Forward All Attached Information to Consumer
Warranty Not Valid Unless Returned to CORSA Exhaust*



Please take time to read and understand these installation instructions.

CORSA recommends that the installation of this system be performed by a qualified service center or professional muffler installer who has the necessary equipment, tools and experienced personnel. However, if you decide to perform this install, the use of a hoist and an additional person will be required.

NOTE: The installation of this Corsa Performance Exhaust system requires cutting and clamping onto the factory system. Ensure measurements and cut locations are correct before cutting the factory exhaust system!

CAUTION: Never work on a hot exhaust system. Allow time for the vehicle to cool. Always wear eye protection when working under a vehicle.

Recommended Tools:

- 3/8" drive ratchet
- 3/8" drive 15mm deep socket
- Grommet pullers
- Soap and water solution
- Torque Wrench
- Chain cutters
- File or deburring tool
- Safety glasses

Please confirm that all parts are present before beginning the factory exhaust system removal and CORSA exhaust system installation.

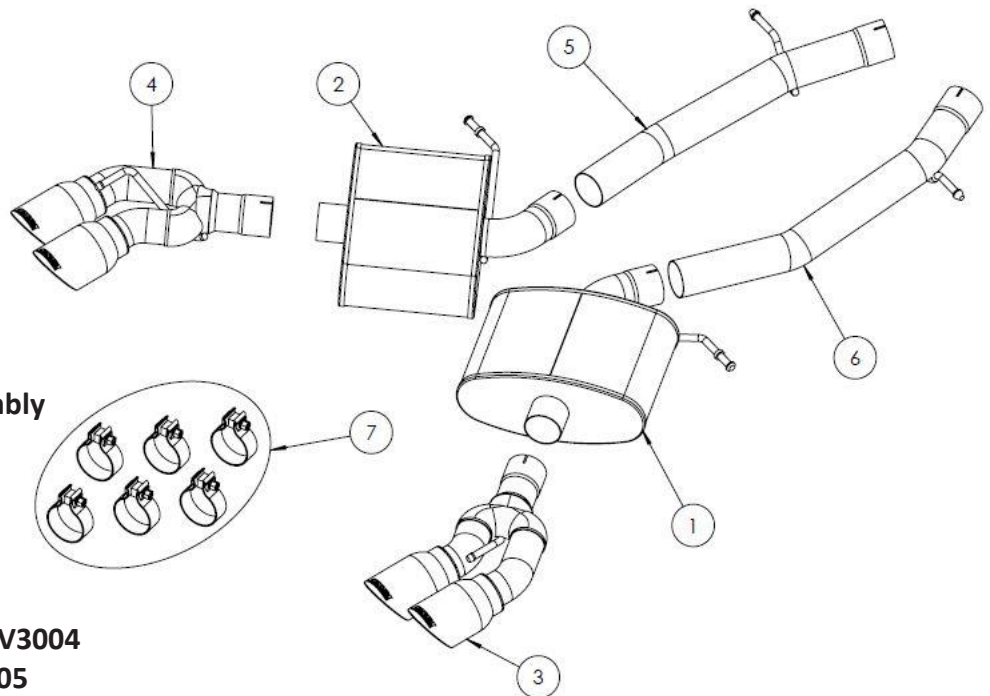

1. Passenger Rear Muffler Assembly
 - a. 15CV2098 – Xtreme
 - b. 15CV2102 – Sport
2. Driver Rear Muffler Assembly
 - a. 15CV2099 – Xtreme
 - b. 15CV2103 – Sport
3. Passenger Tip Assembly – 15CV3004
4. Driver Tip Assembly – 15CV3005
5. Driver Axle Pipe Assembly – 15CV4069
6. Passenger Axle Pipe Assembly – 15CV4070
7. Hardware Kit – 17CH7008

Factory Exhaust System Removal:

1. Beginning at the rear of the vehicle near the tips, locate the electrical connectors for the exhaust valves on each side of the vehicle. **(Fig. A)** Open the small, grey retainer by gently pulling backwards slightly. Once the small clip has been opened, disconnect the wire from the valve. This feature is not retained on the Corsa Performance Exhaust system, so the electrical connector can be taped up or otherwise sealed from the environment and secured out of the way behind the bumper/valence. Repeat this step on the opposite side of the vehicle.
2. On the driver's side of the vehicle, locate the exhaust hanger nearest the differential. Measure from the edge of the hanger forward on the vehicle, along the exhaust pipe 5.4 inches and make a mark. **(Fig. B)**
3. On the passenger's side of the vehicle, locate the hanger nearest the rear differential. Again, from the edge of the hanger measuring forward on the vehicle along the exhaust pipe, make a mark at 5.0 inches. **(Fig. C)**
4. After ensuring the marked locations are correct on both sides, cut the exhaust pipes on the marks using a chain cutter or other suitable device. **(Fig. D)**
5. Using a grommet puller or similar device and beginning near the cut locations, remove the factory rubber grommets from the vehicle chassis on both sides of the vehicle. **(Fig. E)** The use of a soap and water solution may aid in removing exhaust hangers from the rubber grommets.

NOTE: Using jack stands or some other appropriate prop device(s), support the cut ends of the factory exhaust system before removing any more rubber grommets.

6. Remove the factory muffler hangers from the grommets using grommet pullers or a similar device. **(Fig. F)** The use of a soap and water solution may aid in removing exhaust hangers from the rubber grommets.

NOTE: After these secondary hangers are removed, the exhaust will only be supported by the rear hangers near the exhaust tips and the jack stands or supports from Step #5. Take care with the factory exhaust system as to not injure yourself or damage the vehicle.

7. At the cut location, lower the rear portion of the exhaust slightly to gain clearance between the rear pipes and the factory front section of the exhaust. **(Fig. G)** With the help of another person, support the rear exhaust section at both ends. From the front part of the section near the cut points, gently pull the exhaust forward until the rear hangers near the tips are removed from the rubber grommets. Carefully lower the exhaust system from the vehicle. The use of a soap and water solution may aid in the removal of hanger grommets. At this time, using a file or similar device, deburr the remaining pipe on the vehicle.
8. With the factory exhaust on the ground, remove the rubber grommets near the cut location using grommet pullers or a similar device. **(Fig. H)** Reinstall these rubber grommets on the vehicle with the larger end mounted to the chassis of the vehicle. **(Fig. J)** This concludes the removal of the factory exhaust system.

REMOVAL PICTURES ON NEXT PAGE 

Factory Exhaust System Removal Pictures:



Fig. A



Fig. B



Fig. C



Fig. D

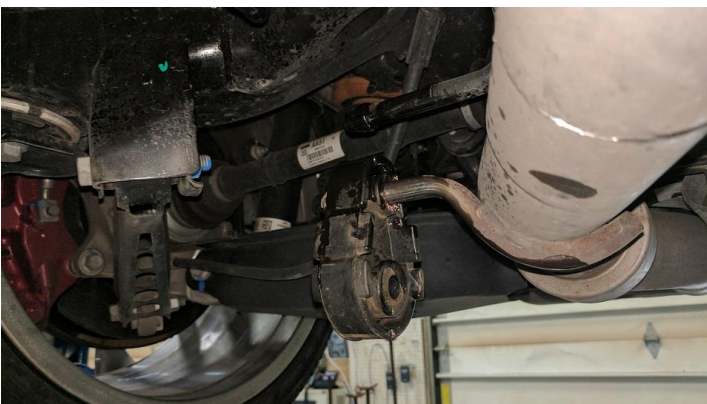

Fig. E



Fig. F

REMOVAL PICTURES CONTINUED ON NEXT PAGE 

Factory Exhaust System Removal Pictures:



Fig. G



Fig. H

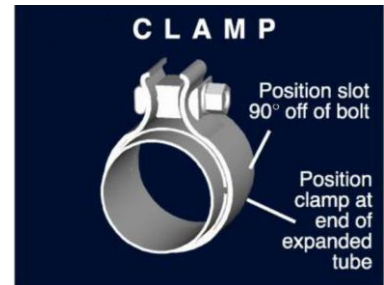

Fig. J

Installation of CORSA Exhaust System:

NOTE: Apply the anti-seize lubricant (supplied) to the threads **ONLY** of all the clamps and flange bolts. Failure to follow this procedure can cause nuts to seize on clamps and potentially destroy threads. After applying anti-seize lubricant, be sure to thoroughly clean your hands, as lubricant will tarnish stainless steel. All clamps should be tightened using a properly calibrated Torque Wrench. Using an air impact gun will damage the clamp and reduce its ability to effectively seal the joint. It may also cause the joint to separate, thereby causing damage to your exhaust system and to your vehicle.

NOTE: Align all clamps so that the center of the clamp bolt is 90 degrees from the notch in the pipe. (See Fig. CLAMP)



1. Remove all exhaust system components from the shipping boxes, including clamps and hardware.
2. Locate one of the 2.75" clamps from the hardware kit. Slip the clamp over the cut end of the passenger front exhaust section with the bolt towards the outside of the vehicle and the nut down. **(Fig. K)** Insert the passenger's side axle pipe assembly into the rubber grommet **(Fig. L)** and slide the expanded end over the cut portion of the factory exhaust. **(Fig. M)** Snug the clamp using a 15mm deep socket and ratchet.
3. Next, locate the driver axle pipe muffler assembly and another 2.75" clamp. Repeat Step #2 on the driver's side of the vehicle
4. Locate the passenger's side tip assembly and another 2.75" clamp. Insert the passenger's side tip hanger into rubber grommet. **(Fig. N)** Slide the clamp over the expanded end of the tip assembly with the bolt toward the outside of the vehicle and the nut down. **(Fig. P)**
5. Repeat Step #4 on the driver's side of the vehicle, using the driver's side tip assembly and another 2.75" clamp.
6. Locate the passenger's side muffler assembly and another 2.75" clamp. Slide the clamp over the outlet of the axle pipe, again with the bolt towards the outside of the vehicle and the nut facing down. **(Fig. Q)** Insert the rear muffler hanger through the rubber grommet **(Fig. R)**, followed by sliding the expansion over the axle pipe **(Fig. S)** and the tip over the outlet of the muffler. Snug the both clamps using the 15mm deep socket and ratchet.
7. Repeat Step #6 on the driver's side of the vehicle with the remaining muffler and the last clamp.

INSTALLATION INSTRUCTIONS CONTINUED ON NEXT PAGE



8. Adjust the system accordingly, including pipe overlaps, pipe, muffler, and tip rotations so that the tips are centered within the bumper cut outs. **(Fig. T)** Check clearance between system components and the chassis. Confirm there is space between the driver's side tip and the trunk floor pan and heat shield. At this time, tighten all clamps to 45ft-lbs using the torque wrench and 15mm deep socket. This concludes the Corsa Performance Exhaust installation.

NOTE: During cold weather start-ups, you may experience an exhaust sound that is deeper and louder in tone than usual. This is temporary and will diminish to normal levels once your engine has reached its normal operating temperature.

NOTE: Immediately following the installation of your exhaust system, you may experience a trace of smoke after initial start-up. DO NOT be alarmed. The smoke is caused by the burning of a small amount of forming oil residue used in the manufacturing process.

INSTALLATION PICTURES ON NEXT PAGE 

Corsa Performance Exhaust Installation Pictures:



Fig. K



Fig. L



Fig. M



Fig. N



Fig. P



Fig. Q

INSTALLATION PICTURES CONTINUED ON NEXT PAGE



Corsa Performance Exhaust Installation Pictures:



Fig. R



Fig. S



Fig. T