



IMPORTANT WARRANTY & INSTALLATION INSTRUCTIONS ATTACHED

*Please Forward All Attached Information to Consumer
Warranty Not Valid Unless Returned to CORSA Exhaust*



Please take time to read and understand these installation instructions.

CORSA recommends that installation of this system be performed by a qualified service center or professional muffler installer who has the necessary equipment, tools and experienced personnel. However, if you decide to perform this install, the use of a hoist and an additional person will be required.

CAUTION: Never work on a hot exhaust system. Allow time for the vehicle to cool. Always wear eye protection when working under a vehicle.

Please confirm that all parts are present before beginning the factory exhaust system removal and CORSA exhaust system installation.

Recommended Tools:

Safety glasses, Torque wrench, 15mm socket or wrench, 13mm socket and an extension, 18mm socket or wrench

PN 14316 Bill of Materials

- 1 Driver Rear Muffler - 20MU2024
- 2 Passenger Rear Muffler - 20MU2025
- 3 Hardware Kit - 20MU7013
- 4 Anti-Seize Lubricant Packet

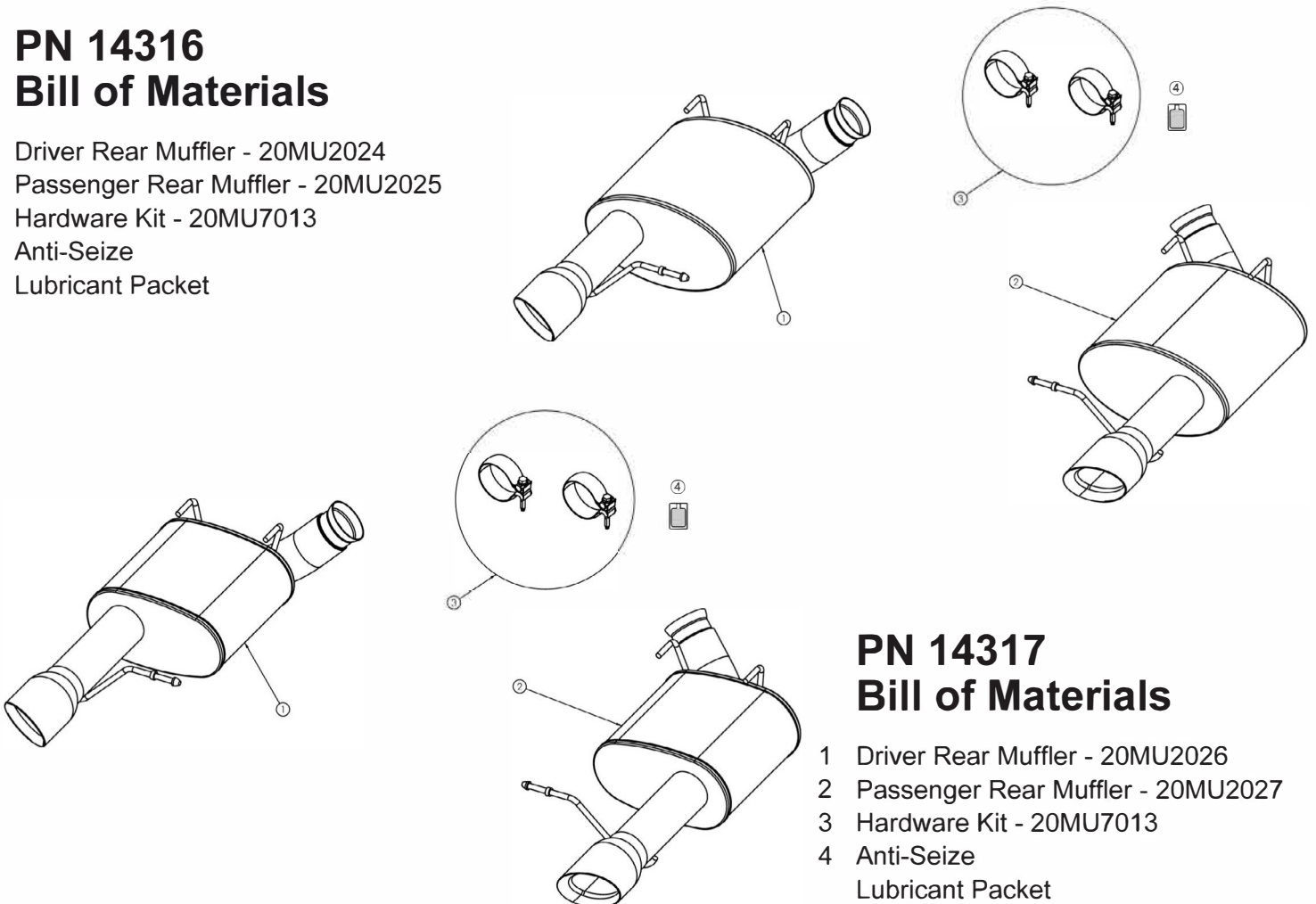

PN 14317 Bill of Materials

- 1 Driver Rear Muffler - 20MU2026
- 2 Passenger Rear Muffler - 20MU2027
- 3 Hardware Kit - 20MU7013
- 4 Anti-Seize Lubricant Packet

PN 14319
Bill of Materials

- 1 Driver Rear Muffler - 20MU2038
- 2 Passenger Rear Muffler - 20MU2039
- 3 Hardware Kit - 20MU7016
- 4 Anti-Seize Lubricant Packet

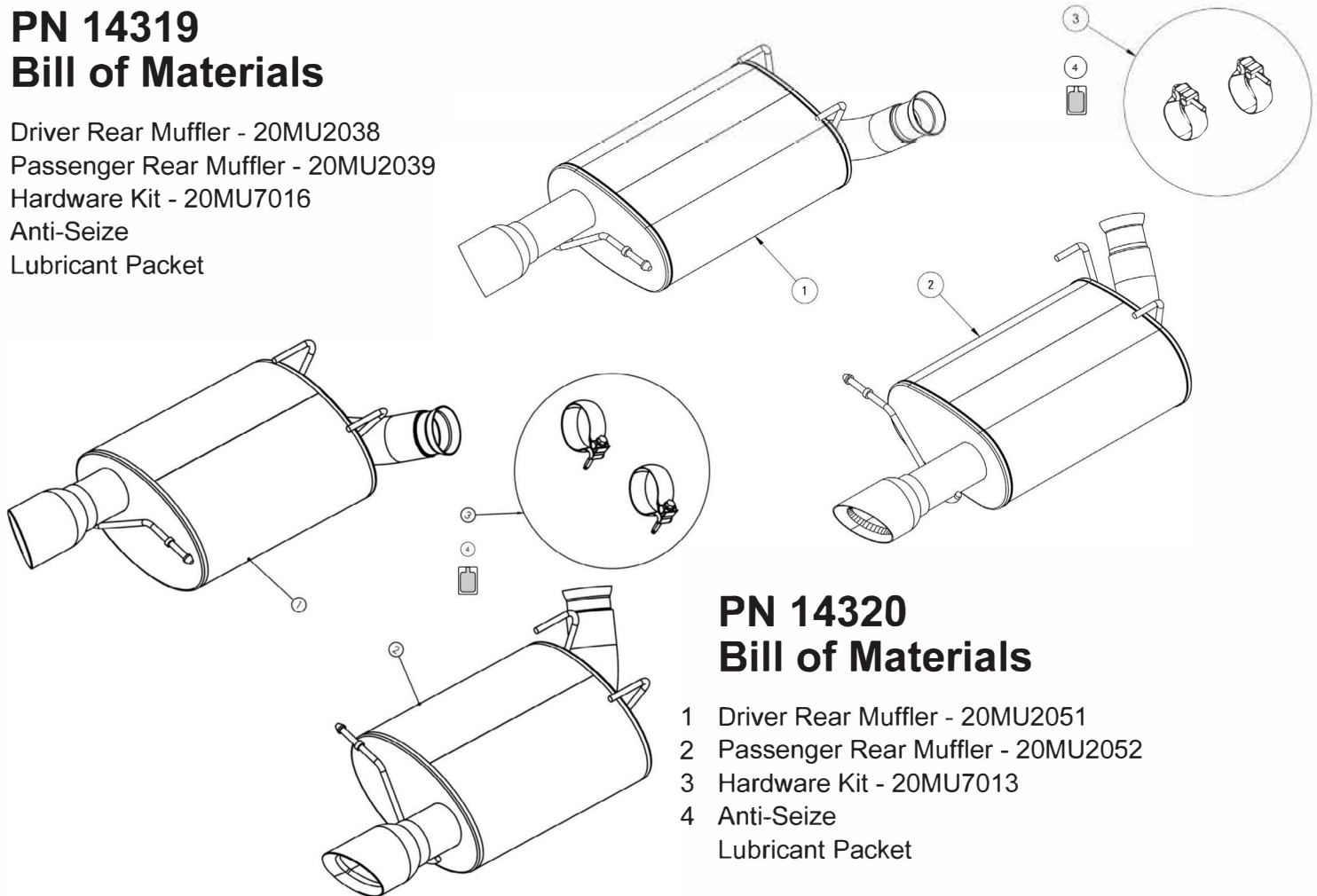

PN 14320
Bill of Materials

- 1 Driver Rear Muffler - 20MU2051
- 2 Passenger Rear Muffler - 20MU2052
- 3 Hardware Kit - 20MU7013
- 4 Anti-Seize Lubricant Packet

Stock Exhaust Removal:

1. Using a 13mm socket or wrench, loosen the clamps before the passenger side and driver side mufflers (See Fig. A).

2. Using a 15mm socket or wrench, loosen the clamps after the h-pipe assembly (See Fig. B).

NOTE: If installing a Corsa XO-pipe (PN: 14318)*, follow the instructions included in that kit and resume to step #3 after XO-pipe install is completed. * For V8 ONLY



Fig. A



Fig. B

3. Using a 15mm socket or wrench, remove the 2 bolts on the driver side of the panhard bar (See Fig. C) and then loosen the bolt on the passenger side end with a 18mm socket or wrench, only enough so that the bar drops freely (See Fig. D). Dropping this bar down will allow the driver side muffler to be removed with less difficulty.



Fig. C

4. Using a grommet puller or similar device, remove the rearmost hanger from the driver side (See Fig. E).

NOTE: Using a soapy water solution on all grommet holes will make the job easier.

5. Pull the axle pipe from the clamp joint (See Fig. F), and while holding the axle pipe out of the way, push the muffler towards the front of the car to remove from two front hangers (See Fig. G).



Fig. D

6. Repeat steps 4&5 on passenger side.



Fig. E



Fig. F

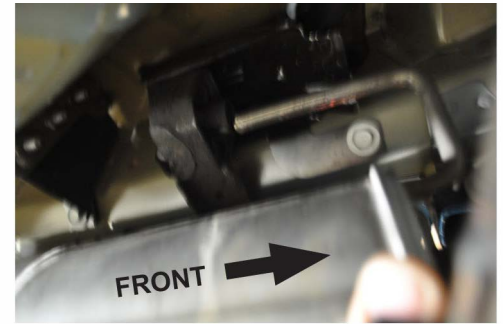

Fig. G

Installation of CORSA Exhaust System:

1. Remove all exhaust components from the shipping cartons, including clamps. **NOTE:** There are two 70mm spherical clamps for the V8 or two 60mm spherical clamps for the V6 supplied.

NOTE: Apply the anti-seize lubricant (supplied) to the threads **ONLY** of all the clamps and flange bolts. Failure to follow this procedure can cause nuts to seize on clamps and potentially destroy threads. After applying anti-seize lubricant, be sure to thoroughly clean hands as lubricant will tarnish stainless steel.

CONTINUE TO NEXT PAGE

2. Locate the passenger side muffler assembly and one spherical clamp. Align the clamp so that it is accessible when installed as shown (See Fig. H).
3. Install front 2 hangers into the grommets (See Fig. I), and slide muffler towards the rear of the car. **NOTE:** Use caution not to hit tip on metal brace near tip bumper opening (See Fig. J).
4. Install rearmost hanger into the rear grommet (See Fig. K).
5. With clamp in place, align muffler inlet flare to mating axle pipe (See Fig. L), and snug clamp with 13mm socket or wrench (See Fig. H).
6. Repeat steps 2-5 on driver side.
7. Re-install the 2 bolts through the panhard bar with a 15mm socket (See Fig. C) and tighten nut on passenger side with 18mm socket or wrench (See Fig. D).
8. Check clearance around axle pipes over axle and tighten 15mm bolts on clamp after h-pipe assembly to 45 lbs-ft. (See Fig. B).
9. Align tips in bumper opening, and while holding in place, tighten spherical clamps to 21 lbs-ft. (See Fig. H). Adjustments can be made by loosening any of the clamp joints and adjusting the rotation or depth.
10. It is **STRONGLY SUGGESTED** that all clamps be checked and re-tightened (if necessary) to the recommended torque after initial road testing of the vehicle, as thermal cycling has occurred on the system. Please wait until the system has fully cooled to perform this step.

NOTE: During cold weather start-ups, you may experience an exhaust sound that is deeper and louder in tone than usual. This is temporary and will diminish to normal levels once your engine has reached its normal operating temperature.

NOTE: Immediately following the installation of your exhaust system, you may experience a trace of smoke after initial start-up. DO NOT be alarmed. The smoke is caused by the burning of a small amount of forming oil residue used in the manufacturing process.



Fig. H

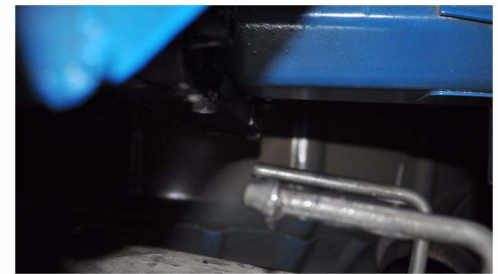

Fig. I



Fig. J



Fig. K

