

# BMW E36 3-SERIES

## Exhaust System Installation

1992-'99 E36, 328 i/is, 325 i/is, 1995-'99 E36 M3 **PN 14552 & PN 14553**

Rear Exit Sport Exhaust System  
w/ Twin 3.0" Pro-Series Tips

**CORSA**<sup>®</sup>  
PERFORMANCE EXHAUSTS

**TOOLS NEEDED:** Safety glasses, two 13mm wrenches or two 1/2" wrenches and 1/2" socket

**PARTS LIST:** (1) Muffler and tip assembly, (4) 8mm-55mm Hex Head Bolts, (4) 8mm nuts

### Exhaust System Removal:

1. Using two 1/2" wrenches, remove the four flange bolts (See Fig A & B).
2. Carefully remove the seal ring and save (See Fig. C). The ring will be used later during the installation of the CORSA system.
3. Remove the nuts located at the rear muffler section, (See Fig. D & E) using a 1/2" socket.
4. Slide the muffler assembly back and then downward to fully remove the factory system. (See Fig. F & G). Continue to Step 5 on page 2.



FIG. A



FIG. B



FIG. C



FIG. D



FIG. E



FIG. F



FIG. G

- Next, remove the factory grommets using a 1/2" socket (See Fig. H & I).

**NOTE:** It is important to inspect these grommets for excessive wear or cracks. If your factory grommets are worn out, do not use them when installing the CORSA system. Worn out grommets will cause the exhaust system to hang too low and move excessively under normal operation. **The BMW part number for the grommet is 18201401797.**

## CORSA Exhaust System Installation:

- Remove the exhaust system assembly from the shipping carton, including the hardware kit (See Fig. J).
- Install the existing or new rubber grommets to the rear muffler hangers. The hole in the grommet favors one side. Be sure to mount the grommet to the hanger so that the hole is favoring the front of the vehicle and is on the outboard side of the hanger. (See Fig. K, L & M).
- When installing the CORSA system, be sure to use the outer most bolt set at the rear muffler location (See Fig. N).
- Locate the four bolts and nuts that are supplied with your CORSA exhaust system (See Fig. O).



FIG. H



FIG. I



FIG. J



FIG. K



FIG. L



FIG. M



FIG. N



FIG. O

5. Slide the CORSA exhaust system over the passenger side pipe and leave the system loose at this time **(See Fig. P & Q)**.
6. Place the rubber grommet mounting holes through the rear bolts that are favoring the passenger side and tighten the nuts using a 1/2" socket. **(See Fig. R & S)**.
7. Repeat step 6 on the driver side mounting holes.
8. Locate the seal ring removed earlier and place between the passenger side head pipe and flange **(See Fig. T & U)**.
9. Slide the flanges forward and install all four flange bolts at this time using two 1/2" wrenches **(See Fig. V)**. Tighten to factory specification.

#### Adjustment Section:

- This is a direct bolt-on system so the amount of adjustment for this system is minimal.
- The tips will line up centered in the valance opening **(See Fig. W & X)**.
- If the center pipes are offset too much to one side, they can be repositioned by loosening the flange bolts at the manifold exit, then re-tightening at the desired location.



FIG. P



FIG. Q



FIG. R



FIG. S



FIG. T



FIG. U



FIG. V



FIG. W



FIG. X

**NOTE:** During cold weather start-ups, you may experience an exhaust sound that is deeper and louder in tone than usual. This is temporary and will diminish to normal levels once your engine has reached its normal operating temperature.

**NOTE:** Immediately following the installation of your CORSA exhaust system, you may experience a trace of smoke after initial start-up. DO NOT be alarmed. The smoke is caused by the burning of a small amount of forming oil residue used in the manufacturing process.

**CORSA**<sup>®</sup>  
PERFORMANCE EXHAUSTS



1992-99  
BMW E36 M3, 328 i/is, 325 i/is models  
Exhaust System  
PN 14552

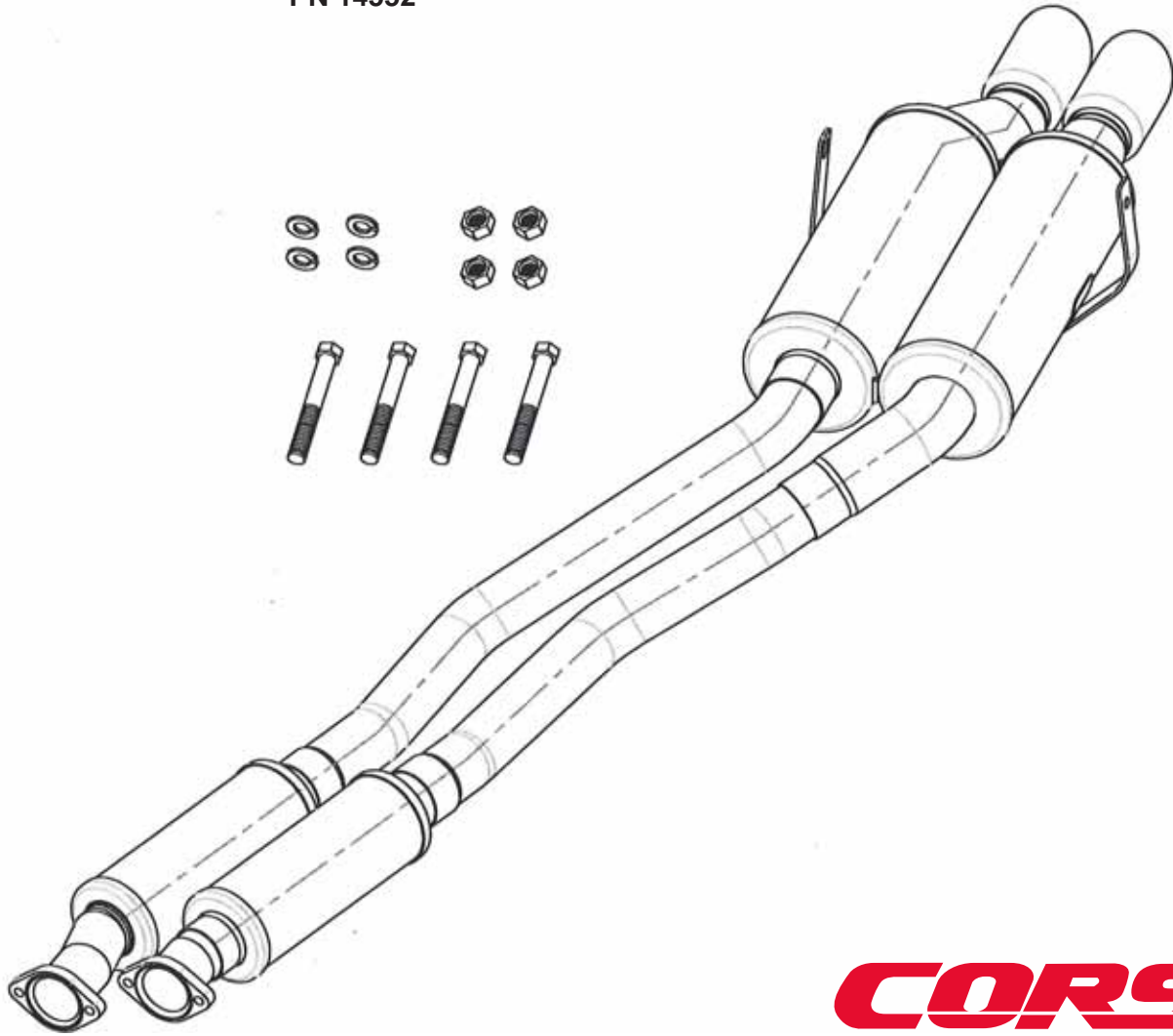

**CORSA**<sup>®</sup>  
PERFORMANCE EXHAUSTS