

CORVETTE C6

Exhaust System Installation

2005-08 Corvette C6

CORSA[®]
PERFORMANCE EXHAUSTS

Recommended Tools:

- 13 mm Socket
- 15 mm Socket
- 18 mm Socket
- 15 mm Open End Wrench
- Torque Wrench
(20-100 ft.-lb.)
- Drive extensions for Ratchet
(MINIMUM OF 17 INCHES)
- Safety Glasses
- Soapy Water

Additional Tools for Auto Transmission Cars Only:

- Large Flat-head
Screwdriver
- Rubber Mallet
- Needle Nose Pliers



PARTS LIST

SPORT SYSTEM (PN 14160) (PN 14169):

- (1) Driver Side Over-the-Axle Pipe (16CS4003)
- (1) Passenger Side Over-the-Axle Pipe (16CS4002)
- (1) Driver Side Muffler Assembly (16CS2064) (16CS2067)
- (1) Passenger Side Muffler Assembly (16CS2065) (16CS2068)
- Hardware Kit (18VP7031):
 - (2) Torca Clamps 2.5"
 - (1) Package Anti-Seize

MANUAL TOURING SYSTEM (PN 14161) (PN 14170): (SPORT + CONVERSION KIT)

- (1) Driver Side Over-the-Axle Pipe (16CS4003)
- (1) Passenger Over-the-Axle Pipe (16CS4002)
- (1) Driver Side Muffler Assembly (16CS2064) (16CS2067)
- (1) Passenger Side Muffler Assembly (16CS2065) (16CS2068)
- (2) Tunnel Muffler Assemblies (16CS2006)
- (1) H-Pipe Assembly (16CS4007)

Hardware Kit (18VP7031):

- (4) Torca Clamps 2.5"
- (1) Package Anti-Seize

Hardware Kit (16CS7003):

- (2) Torca Clamps 2.5"
- (1) Package Anti-Seize

AUTOMATIC TOURING SYSTEM (PN 14168): (SPORT + CONVERSION KIT)

- (1) Driver Side Over-the-Axle Pipe (16CS4003)
- (1) Passenger Over-the-Axle Pipe (16CS4002)
- (1) Driver Side Muffler Assembly (16CS2067)
- (1) Passenger Side Muffler Assembly (16CS2068)
- (2) Tunnel Muffler Assemblies (16CS2006)
- (1) H-Pipe Assembly (16CS4111)

Hardware Kit (16CS7004):

- (4) Torca Clamps 2.5"
- (1) Package Anti-Seize

Hardware Kit (18VP7031):

- (2) Torca Clamps 2.5"
- (1) Package Anti-Seize

MANUAL CONVERSION KIT (PN 14162):

- (2) Tunnel Muffler Assemblies (16CS2006)
- (1) H-Pipe Assembly (16CS4007)

Hardware Kit (16CS7004):

- (4) Torca Clamps 2.5"
- (1) Package Anti-Seize

AUTOMATIC CONVERSION KIT (PN 14159):

- (2) Tunnel Muffler Assemblies (16CS2006)
- (1) H-Pipe Assembly (16CS4111)

Hardware Kit (16CS7004):

- (4) Torca Clamps 2.5"
- (1) Package Anti-Seize

3.5" XTREME SYSTEM (PN 14469):

- (1) Driver Side Over-the-Axle Pipe (16CS4003)
- (1) Passenger Side Over-the-Axle Pipe (16CS4002)
- (1) Driver Side Muffler Assembly (16CS2054)
- (1) Passenger Side Muffler Assembly (16CS2053)

Hardware Kit (18VP7031):

- (2) Torca Clamps 2.5"
- (1) Package Anti-Seize

4.0" XTREME SYSTEM (PN 14960):

- (1) Driver Side Over-the-Axle Pipe (16CS4003)
- (1) Passenger Side Over-the-Axle Pipe (16CS4002)
- (1) Driver Side Muffler Assembly (16CS2071)
- (1) Passenger Side Muffler Assembly (16CS2070)

Hardware Kit (18VP7031):

- (2) Torca Clamps 2.5"
- (1) Package Anti-Seize

CAUTION: Prior to installation, be sure your vehicle is parked on a level surface, and the exhaust system is cool. For safety purposes and ease of installation, we urge you to take your vehicle to a qualified service center or muffler installer that employs the use of a lift.

INSTALLATION NOTE: Be sure to apply the provided anti-seize lubricant to all bolts, fasteners and clamps. A pouch is included with the hardware kit. Apply the supplied anti-seize lubricant to the threads **ONLY** of all TORCA band clamps. Failure to follow this procedure can cause the nuts to seize on clamps and potentially damage threads. **WARNING:** Be sure to thoroughly clean hands after use. Anti-seize lubricant will tarnish stainless steel parts.

All Torca clamps should be tightened using a properly calibrated Torque Wrench. Using an air impact gun will damage the clamp and reduce its ability to effectively seal the joint. It may also cause the joint to separate thereby causing damage to your exhaust system and your vehicle.

Exhaust Removal:

EXHAUST REMOVAL

Your C6 must be raised high enough to remove the one-piece stock muffler and over-axle pipe assemblies. A safe vehicle hoist is strongly recommended for this task.

NOTE: Be sure to save all nuts. These will be used to install your CORSA Performance exhaust system.

1. Using a 15 mm socket or wrench, remove the four front flange nuts (See Fig. A).
2. Using a 13 mm socket or wrench, remove the H-Pipe hanger nuts (See Fig. B).
3. Using a 15 mm socket or wrench, loosen the clamps connecting the H-Pipe to the Rear Muffler Assembly (See Fig. C).
4. Slide the flanges off the bolts (See Fig. D).
5. Remove the H-Pipe assembly.
6. Using an 18 mm socket and a 15 mm open end wrench, remove the rear stabilizer bar mounting nuts (See Fig. E). Both sides.
7. Use an 18 mm socket to remove the upper stabilizer bar mounting bolts (See Fig. F).
8. Swing the stabilizer bar down, away from the rear cradle.



FIG. A



FIG. B



FIG. C



FIG. D



FIG. E



FIG. F

9. On the Passenger side, cut tailpipe 3-4" after H-pipe joint (See Fig. G).
[2005 AUTOMATIC TRANSMISSION ONLY]
10. Slide the rear muffler hangers out of the rubber isolators, using soapy water to aid in removal if needed. (See Fig. H).
11. Carefully slide the Driver side muffler out of the vehicle.
12. Carefully slide the Passenger side muffler out of the vehicle (See Fig. I).
13. Reinstall the stabilizer bar using the factory nuts and bolts. Tighten the bolts and nuts to factory specifications.
14. If installing a CORSA Performance C6 SPORT exhaust system, reinstall the factory crossover at this point. Tighten the flange nuts and the crossover hanger nuts to factory specifications.



FIG. G



FIG. H



FIG. I

CORSA Performance SPORT EXHAUST INSTALLATION:



1. Remove all exhaust system components from the shipping carton, including clamps. **NOTE: There are two 2.5-inch clamps supplied.**
2. Locate the Driver side (16CS4003) and Passenger side (16CS4002) axle pipes (See Fig. L & M).
3. Slide both Driver and Passenger axle pipes into position from the rear (See Fig. N).
4. Insert the axle pipes into the H-Pipe outlets and snug fit the clamps (See Fig. O). **Note: If using the factory H-Pipe, axle pipe will not bottom-out in the expansion. This is as designed.**
5. Locate the Passenger side muffler (16CS2065, 16CS2068 or 16CS2053). Slide one Torca clamp onto muffler inlet (See Fig. AB).
6. Slide the muffler hanger into the factory rubber isolators (See Fig. Y).
7. Carefully align the muffler inlet to the axle pipe.
8. Slide the axle pipe into the muffler inlet expansion and snug fit the Torca clamp using the 17-inch extensions and a 15 mm socket (See Fig. W). **NOTE: All the muffler clamps should point towards the center of the vehicle when installed.**



FIG. L



FIG. M



FIG. N



FIG. O



FIG. AB



FIG. Y



FIG. W

9. Repeat steps 6 to 9 above for the Driver side muffler (16CS2064, 16CS2067 or 16CS2054).
10. Adjust the entire system as necessary to achieve the desired tips location and clearance to all driveline components.
11. Starting from the front of the vehicle, tighten all Torca clamps to **45 ft.-lb.**
12. It is **MANDATORY** that all clamps and fasteners be checked and re-tightened (if necessary) after a road test. Make sure the system has cooled prior to touching any exhaust components.

NOTE: During cold weather start-ups, you may experience an exhaust sound that is deeper and louder in tone than usual. This is temporary and will diminish to normal levels once your engine has reached its normal operating temperature.



NOTE: Immediately following the installation of your CORSA exhaust system, you may experience a trace of smoke after initial start-up. DO NOT be alarmed. The smoke is caused by the burning of a small amount of forming oil residue used in the manufacturing process.



CONVERSION KIT INSTALLATION

CORSA Performance SPORT to TOURING CONVERSION KIT INSTALLATION:

NOTE: Be sure to save all nuts. These will be used to install your CORSA Performance exhaust system.

1. Using a 15 mm socket or wrench, remove the four front flange nuts (**See Fig. A**).
2. Using a 13 mm socket or wrench, remove the H-Pipe hanger nuts (**See Fig. B**).
3. Using a 15 mm socket or wrench, loosen the clamps connecting the H-Pipe to the Rear Muffler Assembly (**See Fig. C**).
4. Slide the flanges off the bolts (**See Fig. D**).



FIG. A



FIG. B



FIG. C



FIG. D

5. Remove the H-Pipe assembly.
6. Remove all Conversion Kit components from the shipping carton.
NOTE: There are four 2.5-inch clamps supplied.
7. Locate one of the tunnel mufflers (16CS2006) (See Fig. P).
8. Slide the flange over the flange bolts and snug tighten the nuts using a 15 mm open end wrench (See Fig. Q). The inlet of the muffler should be towards the center of the vehicle.
9. Repeat step 8 for the other tunnel muffler.
10. Locate the H-Pipe assembly and the four Torca clamps (16CS4007 or 16CS4111).
11. Snug fit the clamps onto the inlet and outlet ends of the H-Pipe assembly (See Fig. R).
12. Slide the H-Pipe assembly onto the tunnel mufflers and tighten both clamps to **45 ft.-lb.** (See Fig. S)
13. Tighten the flange nuts to factory specifications.
14. Insert each axle pipe into the corresponding H-Pipe outlet and tighten both clamps to **45 ft.-lb.**
15. Using a 13 mm socket or wrench, install the H-Pipe hanger nuts. Tighten to factory specifications (See Fig. T).
16. It is **MANDATORY** that all clamps and fasteners be checked and re-tightened (if necessary) after a road test. Make sure the system has cooled prior to touching any exhaust components.



FIG. P



FIG. Q



FIG. R



FIG. S



FIG. T

NOTE: During cold weather start-ups, you may experience an exhaust sound that is deeper and louder in tone than usual. This is temporary and will diminish to normal levels once your engine has reached its normal operating temperature.

NOTE: Immediately following the installation of your CORSA exhaust system, you may experience a trace of smoke after initial start-up. DO NOT be alarmed. The smoke is caused by the burning of a small amount of forming oil residue used in the manufacturing process.



SPORT & XTREME

2005-08 Corvette C6

- PN 14160
- PN 14169
- PN 14469
- PN 14960

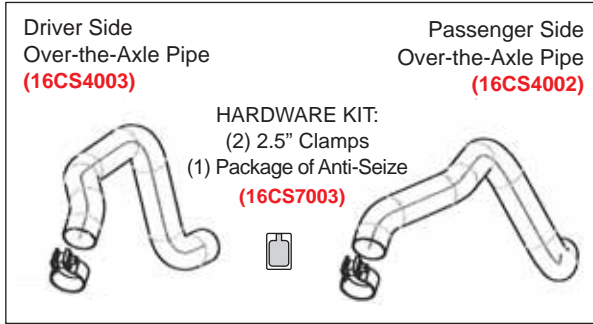

SINGLE SPORT
4.0" Pro-Series Tips
 PN 14160

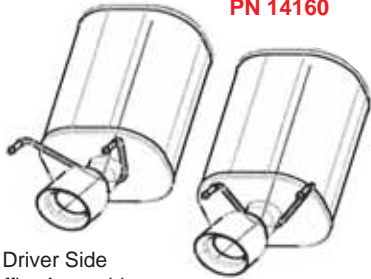

Driver Side Muffler Assembly (16CS2064)

Passenger Side Muffler Assembly (16CS2065)

+
Muffler Assembly

Muffler Assembly Options

QUAD SPORT
Twin 3.5" Pro-Series Tips
 PN 14169

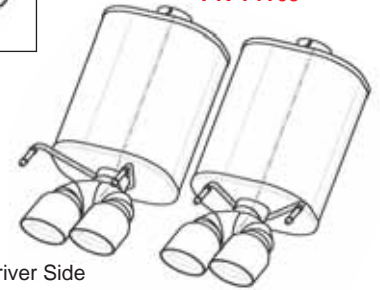

Driver Side Muffler Assembly (16CS2067)

Passenger Side Muffler Assembly (16CS2068)

QUAD XTREME
Twin 3.5" Pro-Series Tips
 PN 14469

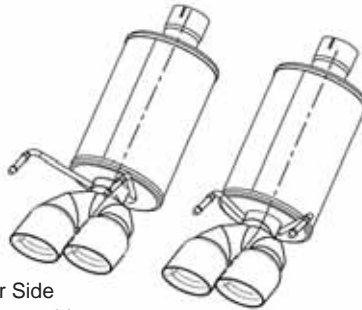

Driver Side Muffler Assembly (16CS2054)

Passenger Side Muffler Assembly (16CS2053)

QUAD XTREME
Twin 4.0" Pro-Series Tips
 PN 14960



Driver Side Muffler Assembly (16CS2071)

Passenger Side Muffler Assembly (16CS2070)



TOURING

2005-08 Corvette C6
 PN 14161, PN 14170, PN 14168

≡ Sport Exhaust System + Conversion Kit

CONVERSION KIT

2005-08 Corvette C6

- PN 14162
- PN 14159

HARDWARE KIT:
 (4) 2.5" Clamps
 (1) Package of Anti-Seize (16CS7004)

