

Please take time to read and understand these installation instructions.

We recommend that the installation of this system be performed by a qualified service center or professional muffler installer who has the necessary equipment, tools and experienced personnel. However, if you decide to perform this install, the use of a hoist and an additional person will be required.

**CAUTION:** Never work on a hot exhaust system. Allow time for the vehicle to cool. Always wear eye protection when working under a vehicle.

**Recommended Tools:**

- Torque Wrench
- 12mm, 14mm & 155mm Socket & Ratchet
- Safety glasses
- Soapy Water
- Grommet Pullers

Please confirm that all parts are present before beginning the exhaust system removal and CORSA Exhaust System installation.

**Bill of Materials:**

- 1 – Head Pipe Assembly (25TU4036)
- 2 – Sport Muffler (25TU2000)
- 3 – Front Tailpipe Assembly (24TU4017)
- 4 – Rear Tailpipe Assembly (24TU4035)
- 5 – Side Swept 4.0" Pro-Series Lip Assembly (16TA3000)
- 6 – Hardware Kit (25TU7020)
- 7 – Packet Anti-Seize Lubricant

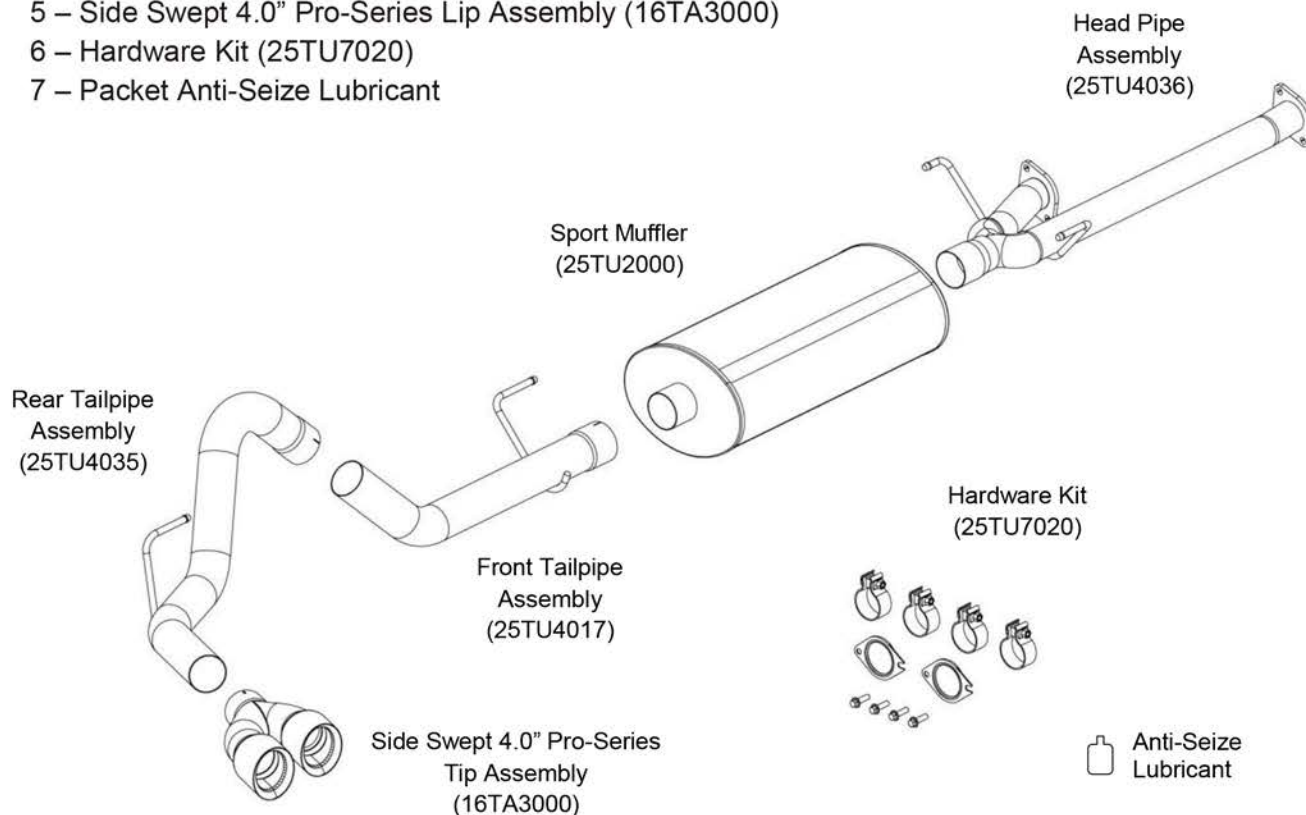

## Removal of Stock Axle Pipe Section:

1. Remove the V-band clamp bolt and clamp located just behind the muffler outlet using a 12mm socket. You do not need to reuse the V-band clamp. **(See Fig. A)**
2. Remove the tailpipe hanger from the rubber grommet using grommet pullers or similar device. Then remove the tailpipe by lifting it up off of the muffler outlet pipe and sliding it back and over the rear axle. **(See Figs. B & C)**  
NOTE: Using a soapy water solution on all grommet holes will make the job easier.
3. Remove the driver and passenger front pipes and muffler by removing the (4) flange bolts after the catalytic converters using a 14mm socket. Save the nuts, you will need to reuse them. **(See Fig. D)**
4. Remove the muffler hangers from the rubber grommets using grommet pullers or similar device and remove the front pipes and muffler assembly. This completes the removal of the stock system. **(See Fig. E, F & G)**



FIG. A



FIG. B



FIG. C



FIG. D



FIG. E



FIG. F



FIG. G



## Installation of CORSA Exhaust System:

**NOTE:** Apply the anti-seize lubricant (supplied) to the threads **ONLY** of all the clamps and flange bolts. Failure to follow this procedure can cause nuts to seize on clamps and potentially destroy threads. After applying anti-seize lubricant, be sure to thoroughly clean hands as lubricant will tarnish stainless steel.

**NOTE:** Align all clamps so that the center of the clamp bolt is 90 degrees from the notch in the pipe (See Fig. H, CLAMP, to the right.)

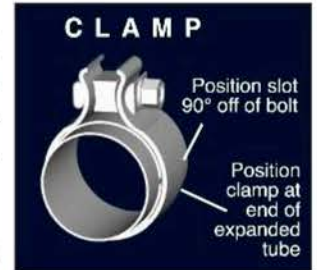

FIG. H

All clamps should be tightened using a properly calibrated Torque Wrench. Using an air impact gun will damage the clamp and reduce its ability to effectively seal the joint. It may also cause the joint to separate thereby causing damage to your exhaust system and your vehicle.

1. Locate the CORSA head pipe assembly. Place the hangers into the factory rubber grommets and then align the head pipe flanges to the factory flanges. Install the supplied flange bolts into both flanges and through the supplied flange gasket bolt holes, ensuring proper flange alignment, using a 14mm socket. Tighten the bolts to  $35 \pm 5$  lbs.-ft. using a torque wrench. (See Fig. I, J & K)
2. Locate the CORSA muffler and slide a supplied 3" Torca clamp over the inlet of the CORSA muffler. Make sure the drain hole on the muffler is facing towards the floor. (See Fig. L) Slide the muffler onto the head pipe assembly and pre-tighten the clamp.
3. Locate the CORSA front tailpipe assembly and slide a supplied 3" Torca clamp over the inlet of the CORSA muffler. Make sure the drain hole on the muffler is facing towards the floor. (See Fig. M & N) Slide the muffler onto the head pipe assembly and pre-tighten the clamp.



FIG. I



FIG. J



FIG. K



FIG. L



FIG. M



FIG. N

Continue to Step 4 on next page...

4. Locate the CORSA rear tailpipe assembly and slide a supplied 3" Torca clamp over the inlet. Slide the tailpipe over the axle and onto the front tailpipe exit. Place the hanger into the factory rubber grommet and pre-tighten the clamp. (See Fig. O, P & Q)
5. Locate the CORSA tip assembly and slide a supplied 3" Torca clamp over the inlet end. Slide the tip assembly onto the tailpipe and adjust the angle and location of the tip to your liking and pre-tighten the clamp. (See Fig. R, S & T)
6. Start from the front of the CORSA exhaust system and tighten all clamps to 45 lbs.-ft. using a torque wrench. This completes the installation of the CORSA exhaust system.

**NOTE: It is strongly recommended that all clamps be checked and tightened after road testing the vehicle. Allow the exhaust system to cool before working on it.**



FIG. O



FIG. P



FIG. Q



FIG. R



FIG. S



FIG. T