

Please take time to read and understand these installation instructions.

CORSA recommends that installation of this system be performed by a qualified service center or professional muffler installer who has the necessary equipment, tools and experienced personnel. However, if you decide to perform this install, the use of a hoist and an additional person will be required.

CAUTION: Never work on a hot exhaust system. Allow time for the vehicle to cool. Always wear eye protection when working under a vehicle.

Please confirm that all parts are present before beginning the factory exhaust system removal and CORSA exhaust system installation.

Recommended Tools:

- Tape measure
- Black marking pen
- 13mm, 15mm socket and ratchet
- Chain style pipe cutter
- Grommet pullers
- Soapy water
- Safety glasses
- Torque Wrench

SPORT PN 14904

143.5" Wheel Base
 Sport PN
 Touring PN

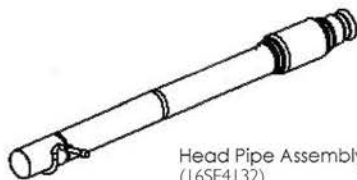

TOURING MUFFLER 14671
 SPORT MUFFLER 14637

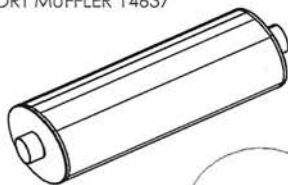

Hardware Kit
 (20FF7026)

Anti-Seize
 Lubricant

133.5" Wheel Base
 Sport PN 14900
 Touring PN 14901

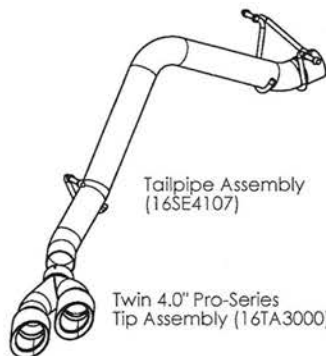

TOURING MUFFLER 14671
 SPORT MUFFLER 14637

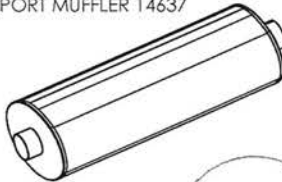

Hardware Kit
 (20FF7026)

Anti-Seize
 Lubricant

Head Pipe Assembly
(16SE4138)

SPORT PN 14900

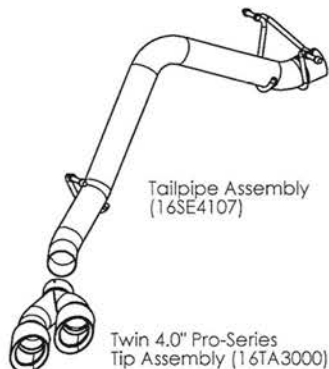

SPORT PN 14925

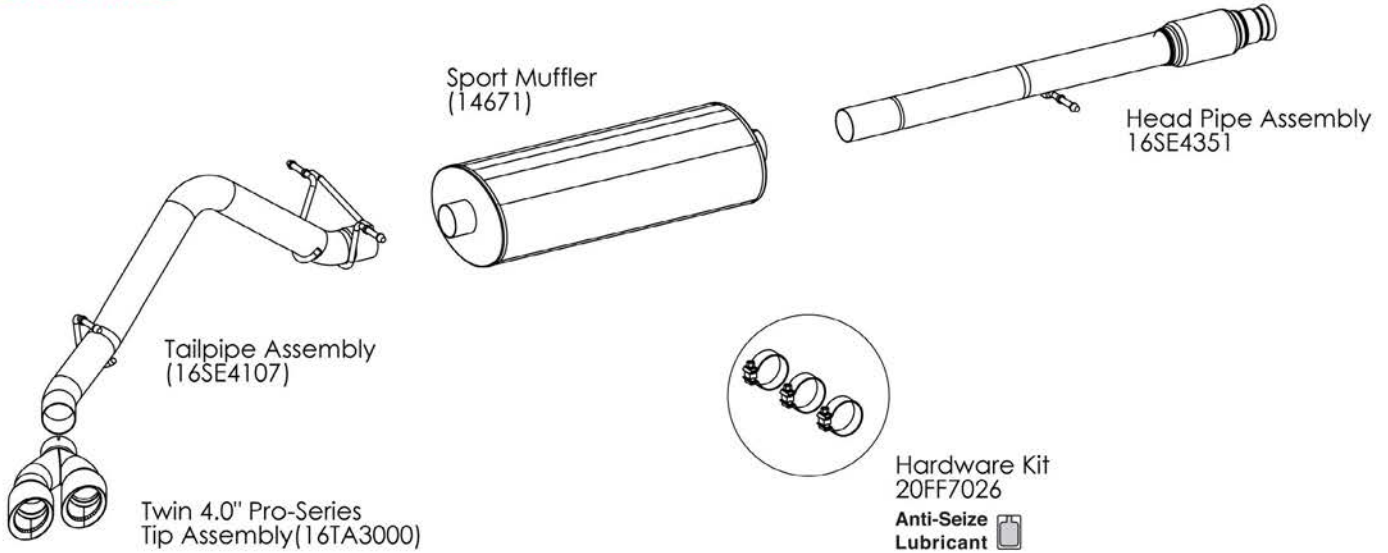

SPORT PN 14920 / TOURING PN 14922

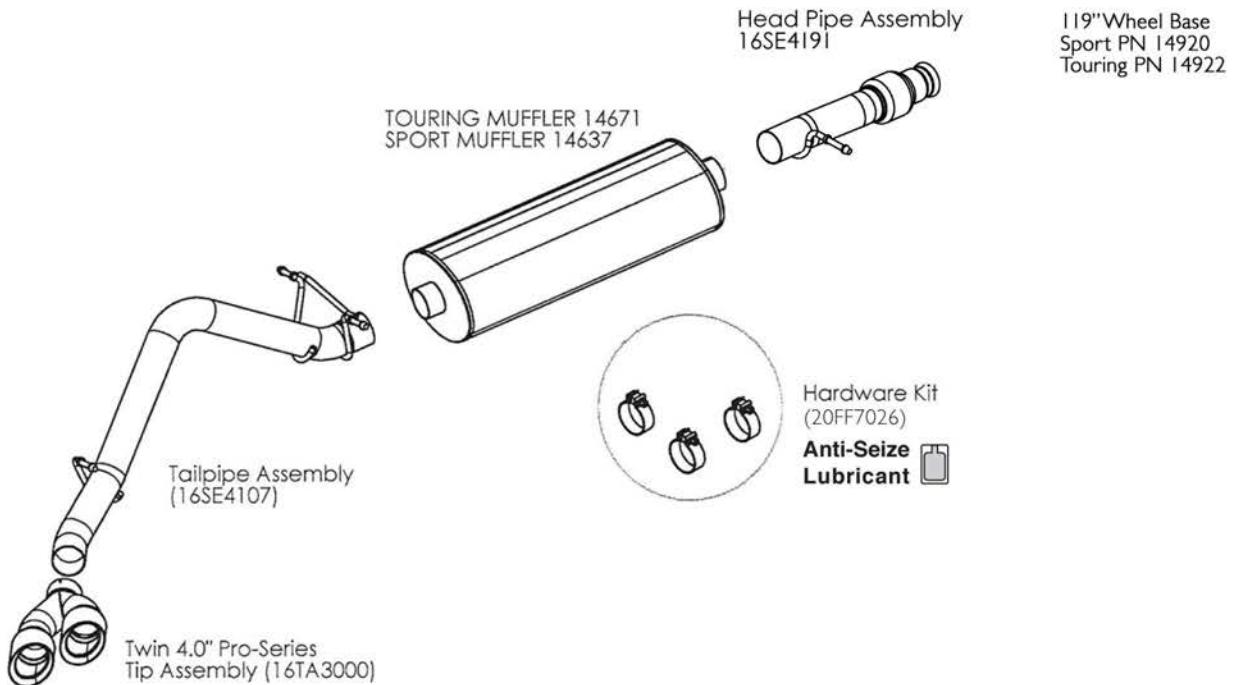

Removal of Stock System:

- 1) Scribe a line 12" from the front face of the stock muffler. **(See Fig. A)**
- 2) Place a chain style cutter around the exhaust pipe at the scribe line location and cut the exhaust pipe. **(See Fig. B)**
- 3) Remove the grommets from the tailpipe hangers at the muffler exit, the spare tire and finally ahead of the muffler, using grommet pullers or similar device. **(See Fig's C, D & E)**
Note: Using a soapy solution on the grommet hole will make the job easier.
- 4) Use a 13mm socket to loosen spherical clamp and remove factory headpipe. **(See Fig. F)**
- 5) Remove the muffler and rear tailpipe section from the vehicle by lifting the tailpipe over the rear axle and forwards toward the front of the vehicle. **(See Fig's G & H)** This completes the removal of the stock system.



FIG. A



FIG. B



FIG. C



FIG. D



FIG. E



FIG. F



FIG. G



FIG. H

Installation of CORSA Exhaust System:

NOTE: Apply the anti-seize lubricant (supplied) to the threads **ONLY** of all the clamps and flange bolts. Failure to follow this procedure can cause nuts to seize on clamps and potentially destroy threads. After applying anti-seize lubricant, be sure to thoroughly clean hands as lubricant will tarnish stainless steel. All clamps should be tightened using a properly calibrated Torque Wrench. Using an air impact gun will damage the clamp and reduce its ability to effectively seal the joint. It may also cause the joint to separate thereby causing damage to your exhaust system and your vehicle.

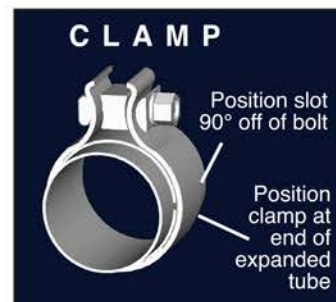

- 1) Locate the CORSA Head Pipe assembly and slide the spherical joint onto the factory pipe. Reuse the factory spherical clamp and loosely snug the spherical joint. Insert the hanger into the factory grommet. **(See Fig. H)**

Note: Using a soapy solution on the grommet hole will make the job easier.

- 2) Slide a supplied 3" TORCA clamp over the inlet of the CORSA muffler. Make sure the weep hole is facing down then slide the muffler onto the Head Pipe and pre-tighten the clamp. **(See Fig's I, J & K)**



FIG. H



FIG. I



FIG. J



FIG. K

- 3) Slide a supplied 3" TORCA clamp over the inlet of the CORSA Tailpipe. From the rear of the vehicle slide the pipe over the axle while holding the rear differential vent hose out of the way. Insert the pipe over the muffler exit and place the hangers into the factory grommets. Pre-tighten the clamp. **(See Fig's L, M, N & O)**
Note: Using a soapy solution on the grommet hole will make the job easier.
- 4) Slide a 3" TORCA clamp over the tip assembly and place the tip onto the end of the tailpipe. Pre-tighten the clamp at this time. **(See Fig's P & Q)**
- 5) Adjust all CORSA components to attain clearance to surrounding parts. Starting from the front of the CORSA exhaust system tighten all spherical clamps to **21 ft.-lbs.** and TORCA clamps to **45 ft.-lbs** using a torque wrench.
- 6) **It is strongly suggested that all clamps be checked and tightened after road testing the vehicle once the system has cooled.**



FIG. L



FIG. M



FIG. N



FIG. O



FIG. P



FIG. Q