



Exhaust System Installation
Cat-Back Exhaust System
2011-13 Dodge Avenger/Chrysler 200 V6
Dual Rear Exit w/ Pro-Series 4.0" Tips
PN 14413

Please take time to read and understand these installation instructions.

CORSA recommends that installation of this system be performed by a qualified service center or professional muffler installer who has the necessary equipment, tools and experienced personnel. However, if you decide to perform this install, the use of a hoist and an additional person will be required.

CAUTION: Never work on a hot exhaust system. Allow time for the vehicle to cool. Always wear eye protection when working under a vehicle.

Please confirm that all parts are present before beginning the factory exhaust system removal and CORSA exhaust system installation.

Bill of Materials:

- 1- Tunnel Muffler Assembly (17JS2000)
- 2- Intermediate Pipe Assembly (17JS4004)
- 3- Driver Rear Muffler Assembly (17JS2002)
- 4- Passenger Rear Muffler Assembly (17JS2006)
- 5- Tip Assembly (17JS3001)
- 6- Hardware Kit (15CV7000)

- Safety Glasses
- 15mm Socket
- 3/8" Ratchet
- Torque Wrench
- Grommet Pullers
- Soap & Water Solution

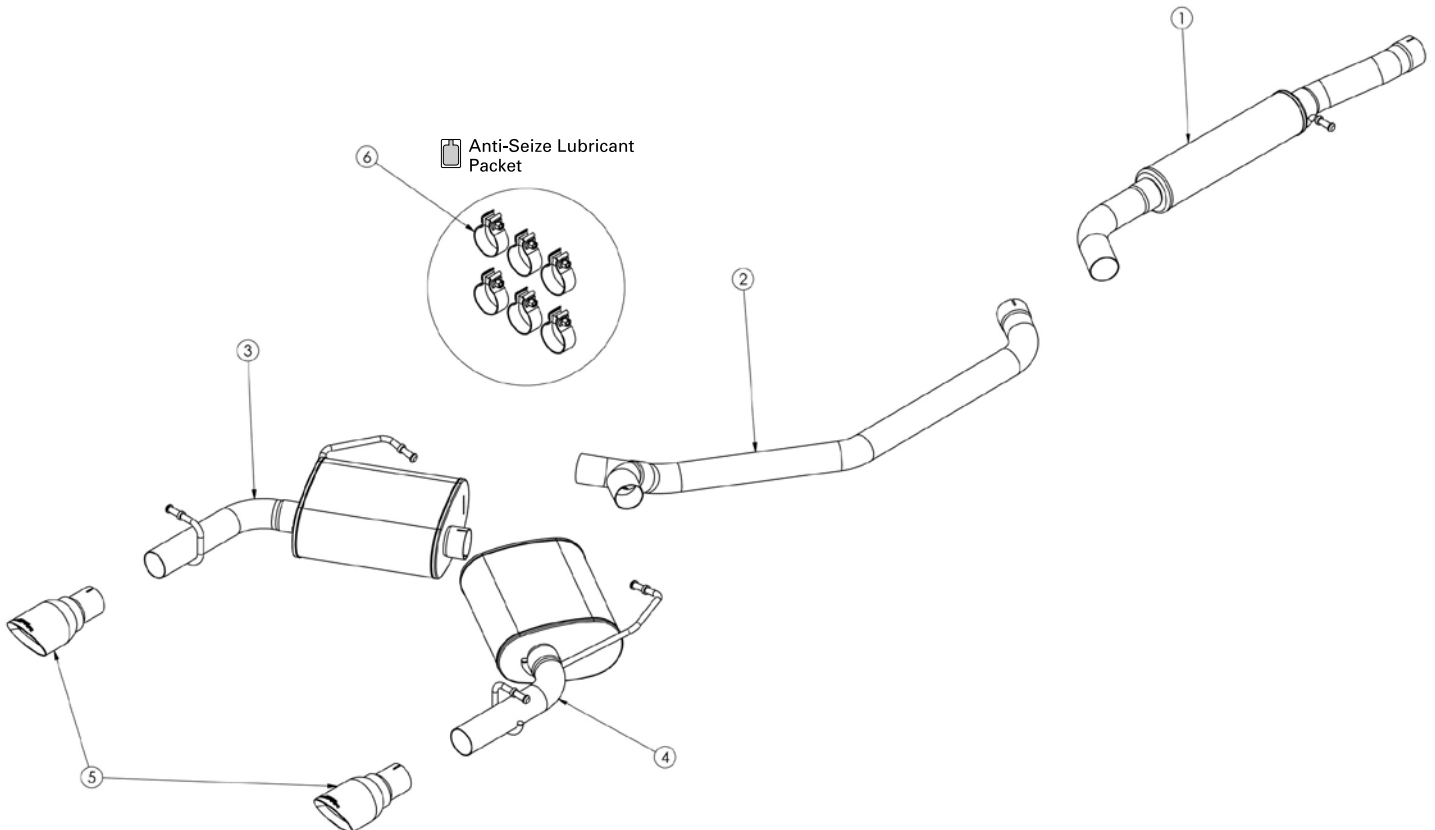

Removal of Stock System:

1. Using a 15mm socket and ratchet, loosen the clamp near the front of the factory catback section **(See Fig. A)**.
2. Begin to remove the hangers from the factory grommets. Grommet pullers and a soapy water solution will aid in this process. Also, use jackstands or the help of another person to support the exhaust system before removing all hangers to prevent injury and/or damage to the rear fascia **(See Fig. B, C, D, E, F)**.
3. After removing all hangers from the factory grommets, pull the factory catback towards the rear of the car to remove from the factory headpipe **(See Fig. G)**.
4. The removal of the stock exhaust is now complete **(See Fig. H)**.



Fig. A



Fig. B



Fig. C



Fig. D



Fig. E



Fig. F



Fig. G



Fig. H

Installation of CORSA Exhaust System:

NOTE: Apply the anti-seize lubricant (supplied) to the threads **ONLY** of all the clamps and flange bolts. Failure to follow this procedure can cause nuts to seize on clamps and potentially destroy threads. After applying anti-seize lubricant, be sure to thoroughly clean hands as lubricant will tarnish stainless steel.

NOTE: Align all clamps so that the center of the clamp bolt is 90 degrees from the notch in the pipe (See clamp figure to the right).

All clamps should be tightened using a properly calibrated Torque Wrench. Using an air impact gun will damage the clamp and reduce its ability to effectively seal the joint. It may also cause the joint to separate thereby causing damage to your exhaust system and your vehicle.

1. Locate the CORSA tunnel muffler assembly and a supplied 2.5" clamp (See Fig. I).
2. Slide the clamp over the expanded end of the tunnel muffler assembly oriented as shown. Then slide the expanded end of the tunnel muffler over the factory headpipe. Insert the tunnel muffler hanger into the factory grommet. Loosely snug the clamp at this time (See Fig. J, K, L).
3. Locate the CORSA intermediate pipe and a supplied 2.5" clamp (See Fig. M).
4. Slide the clamp over the expanded side of the intermediate pipe and slide the expanded end of the intermediate pipe over the tunnel muffler outlet pipe. Use a jackstand to support the middle or rear of the intermediate pipe. The middle section of the intermediate pipe should be level and the outlets centered on the vehicle. Loosely snug the clamp at this time (See Fig. N, O).

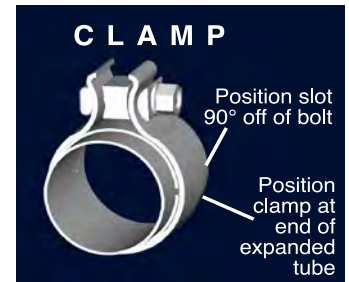

Fig. I



Fig. J



Fig. K



Fig. L



Fig. M



Fig. N



Fig. O

5. Locate the CORSA driver side rear muffler and a supplied 2.5" clamp. Slide the clamp over the expanded muffler inlet pipe and slide the muffler inlet onto the intermediate pipe outlet. Insert the hangers into the factory grommets. Support the muffler so that the muffler outlet pipe is level and loosely snug the clamp at this time **(See Fig. P, Q, R, S).**

6. Locate the CORSA tip assembly and a supplied 2.5" clamp. Slide the clamp over the tip inlet pipe and slide the tip onto the muffler outlet pipe. Check tip alignment and loosely snug the clamp at this time **(See Fig. T, U).**

7. Repeat steps #6 and #7 for the passenger side.

8. Make any necessary and final adjustments for proper clearances and tip alignments. Starting from the front of the exhaust system, tighten all clamps to 45 ft-lbs **(See Fig. V).**

9. It is **STRONGLY SUGGESTED** that all clamps be checked and tightened if necessary after road testing the vehicle and only after system has cooled.



NOTE:
Drain
hole in
mufflers
should
face down.



Fig. P



Fig. Q



Fig. R



Fig. S



Fig. T



Fig. U



Fig. V

NOTE: During cold weather start-ups, you may experience an exhaust sound that is deeper and louder in tone than usual. This is temporary and will diminish to normal levels once your engine has reached its normal operating temperature.

NOTE: Immediately following the installation of your CORSA exhaust system, you may experience a trace of smoke after initial start-up. **DO NOT** be alarmed. The smoke is caused by the burning of a small amount of forming oil residue used in the manufacturing process.