

**Please take time to read and understand these installation instructions.**

CORSA recommends that installation of this system be performed by a qualified service center or professional muffler installer who has the necessary equipment, tools and experienced personnel. However, if you decide to perform this install, the use of a hoist and an additional person will be required.

**CAUTION:** Never work on a hot exhaust system. Allow time for the vehicle to cool. Always wear eye protection when working under a vehicle.

Please confirm that all parts are present before beginning the factory exhaust system removal and CORSA exhaust system installation.

PN14172 & PN 14164

Bill of Materials:

- Driver Side Rear Muffler Assembly  
Single Pro-Series Tips  
PN14172 (16CS2037)  
PN14164 (16CS2047)
- Passenger Side Rear Muffler Assembly  
Single Pro-Series Tips  
PN14172 (16CS2036)  
PN14164 (16CS2046)
- Driver Side Over the Axle Pipe  
(16CS4021)
- Passenger Side Over the Axle Pipe  
(16CS4020)
- (2) 3" Clamps
- (1) Anti-seize Lube Pouch
- (2) Vacuum Caps

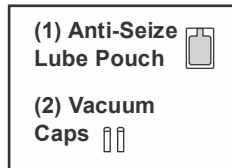

- Recommended Tools:
- Safety Glasses
  - 13mm Socket
  - 15mm Wrench
  - 15mm Socket
  - 18mm Socket
  - Grommet Pullers
  - 3/8" Ratchet
  - 12" Ratchet Extension
  - Torque Wrench
  - Saw or Chain-Style Pipe Cutter

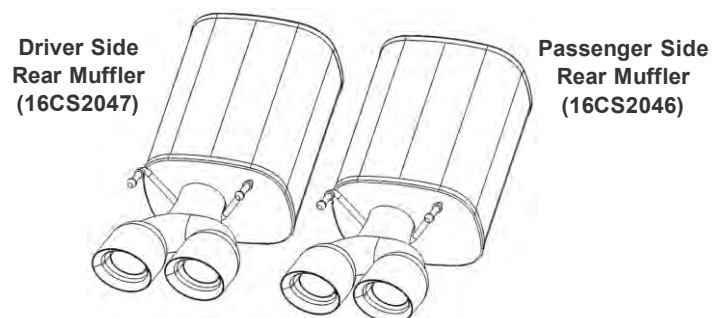
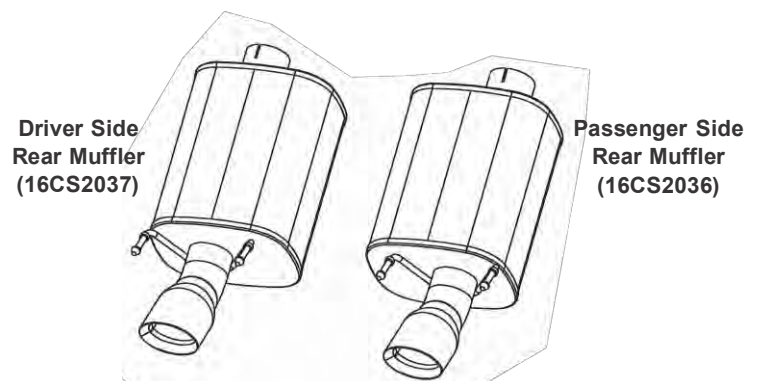
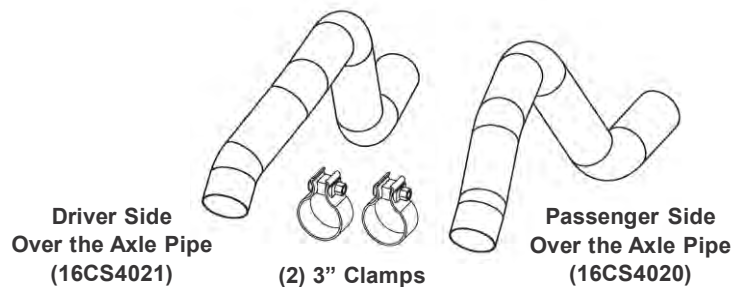

PN14173  
 (2006-2011)

Bill of Materials:

- X-Pipe Assembly  
 (16CS4028)
- (2) 3" Clamps
- (1) Anti-seize  
 Lube Pouch

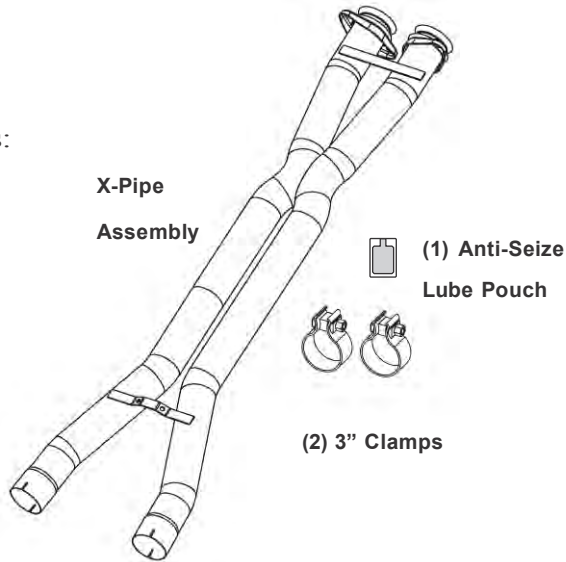

PN14331  
 (2012-13)

Bill of Materials:

- XO-Pipe Assembly  
 (16CS4140)
- (1) Anti-seize  
 Lube Pouch
- (4) Bolts
- (4) Nuts
- (2) 3" Clamps

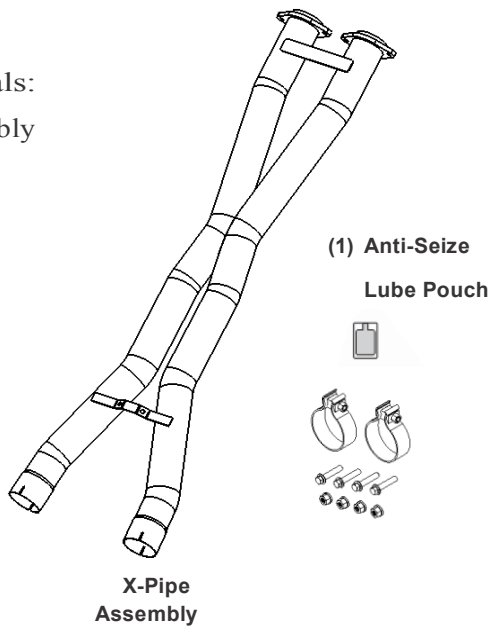

### Factory Exhaust System Removal:

1. Unbolt the rear sway bar brackets from the rear cross member using an 18mm socket on the top and bottom bolts. A 15mm wrench will be needed to hold the lower bolt from turning while the nut is removed. **(See Fig. A). Do not remove lower bolt from suspension.**

**NOTE:** All factory nuts and bolts will be reused to install your CORSA system, do not discard.

2. Pull the sway bar towards the rear of the car to clear the studs and rotate it down on the end links. This will give the necessary clearance to remove the stock mufflers. **(See Fig. B)**

**NOTE:** Due to a mid-year change by Chevrolet, vehicles delivered later in the 2006 model year and beyond MAY NOT need to make the cut mentioned in Step 3. After completing Steps 4-10, the stock system may be removed in one piece by rotating the rear muffler to gain clearance as needed; the cut will make removal of the stock system easier, but is not required.

3. The passenger side pipe needs to be cut to remove the stock system. Measure 2.75" to the rear from the clamp on the exit end of the factory H-pipe and mark the pipe at this distance. Using a chain style pipe cutter, cut the pipe along the mark. **(See Fig. C)**
4. Loosen both driver and passenger clamps at rear of stock H-pipe using a 15mm socket. **(See Fig. D)**
5. Remove both nuts that hold the H-pipe hanger using a 13mm socket. An extension may be needed to access these nuts. **(See Fig. E)**



FIG. A



FIG. B



FIG. C

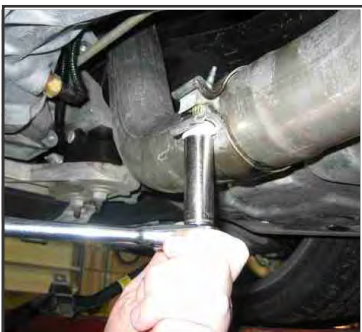

FIG. D



FIG. E

6. Remove the 4 nuts and bolts (4 nuts only on 2012-13 model years) attaching the inlet of the factory H-pipe to the flanges downstream of the catalytic converters using a 15mm socket.  
(See Fig. F-1 (2006-2011) or Fig. F-2 (2012-13))
7. Slide the now loose flanges on the H-pipe towards the rear of the car until they clear the studs and pull the entire H-pipe assembly out of the car. The driver side pipe, leading to the muffler, should slide from the clamp that was loosened in step 4. (See Fig. G & H)  
**NOTE: Push H-pipe towards rear to avoid damaging donut gasket.**
8. Locate the vacuum lines attached to the outlet side of each muffler, near the tips. Detach line from each muffler. No tools are required. (See Fig. I)
9. Starting with the passenger side, remove the rear mufflers from the two rubber grommets holding each muffler in place. Use soapy water to facilitate removal. (See Fig. J)
10. The muffler is now free and should be removed from the car by pulling the muffler down while the attached pipe goes over the axle. (See Fig. K & L)
11. Repeat steps 9&10 for the driver side.
12. Remove the soft rubber end from vacuum line if it did not stay attached to the muffler assembly. (See Fig. I)



FIG. F-1



FIG. F-2



FIG. G



FIG. H

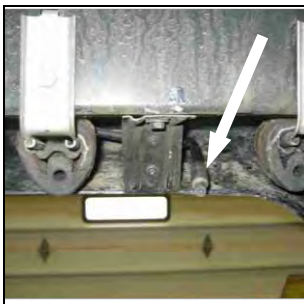

FIG. I



FIG. J



FIG. K



FIG. L

FOR TECHNICAL ASSISTANCE, PLEASE CALL: (800) 486-0999.

## CORSA Exhaust System Installation:

**NOTE:** Apply the anti-seize lubricant (supplied) to the threads **ONLY** of all the clamps and flange bolts. Failure to follow this procedure can cause nuts to seize on clamps and potentially destroy threads. After applying anti-seize lubricant, be sure to thoroughly clean hands as lubricant will tarnish stainless steel.

All clamps should be tightened using a properly calibrated Torque Wrench. Using an air impact gun will damage the clamp and reduce its ability to effectively seal the joint. It may also cause the joint to separate thereby causing damage to your exhaust system and your vehicle.

1. Hand tighten the front of the CORSA X-pipe (or stock H-pipe if reusing) to the flanges using the bolts and/or nuts as removed in step 6 of removal process.

(See Fig. M-1(2006-2011) Fig. M-2(2012-13))

2. Fully tighten the nuts to the spring loaded hanger bolts after sliding the bolt through the hanger hole. (See Fig. N)



FIG M-1



FIG M-2

**Skip Step 3 if reusing stock H-PIPE.**

3. Place supplied TORCA clamp over the expanded end of X-pipe. Make sure the orientation is correct (See Fig. O).
4. Slide the passenger side axle pipe labeled 16CS4020 into the expansion. Do not tighten clamp at this time. (See Fig. P) Repeat on the driver side using axle pipe labeled 16CS4021.
5. Before installing the rear mufflers, cap both vacuum lines in the rear bumper with the supplied rubber caps.
6. Starting on the driver side, push the rear hangers on the muffler into the rubber grommets. (See Fig. Q)

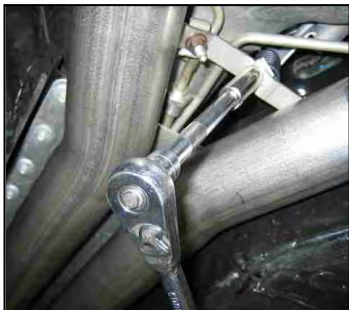

FIG. N

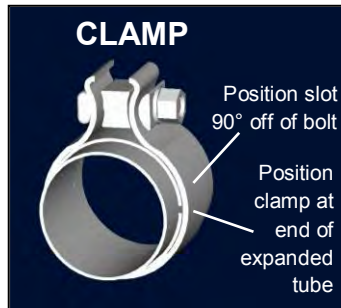

FIG. O



FIG. P

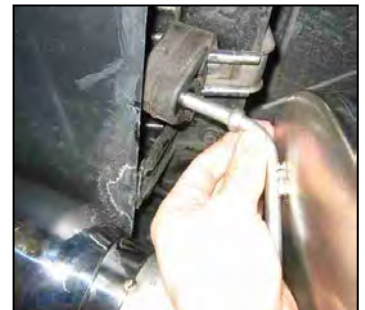
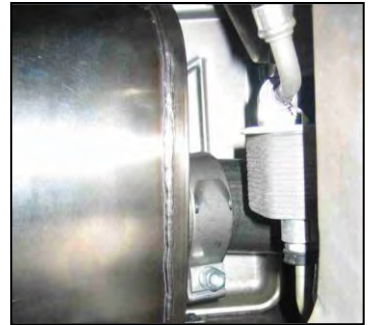

FIG. Q

7. Place TORCA clamp on inlet side of driver side muffler in the correct orientation and with the bolt to the outside of the car. Tighten the clamp so it has a light snug fit on the muffler, just enough to prevent spinning during assembly. **(See Fig. R)**
8. Align the muffler inlet with the axle pipe and slide the pipe into the expanded muffler inlet. **(See Fig. S)**
9. At this point, the axle pipe is free to rotate and should be adjusted so it does not come in contact with the frame rail to the outside or the transmission lines to the inside. After the pipe is centered and free of obstructions, continue to next step.
10. Locate the hole in the rear suspension cross member and slide a 15mm socket and extension through the hole. Stay to the front of the hard line leading to the transmission cooler and tighten the clamp on the inlet side of the muffler. **(See Fig. T & U)**  
**NOTE: Slide muffler front to rear to gain access to the clamp.**
11. Check to make sure the tip is oriented correctly and then tighten the axle pipe joint at the XO-pipe clamp. Rotational and depth adjustments can be made at this joint before tightening. **(See Fig. V)**
12. Repeat steps 7-12 for the passenger side.
13. Adjust the grommets on the rear hangers so that they are centered between the control shoulders. The grommets have the ability to slide front to rear. **(See Fig. W)**



**FIG. R**



**FIG. S**



**FIG. T**



**FIG. U**

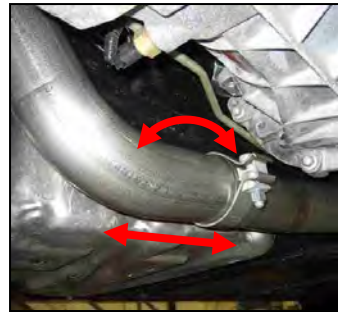

**FIG. V**



**FIG. W**

14. Reinstall the rear sway bar by tightening the top bolt and lower nut on each side with a 18mm socket and use a 15mm wrench to prevent the lower bolt from turning. **(See Fig. X)**
15. Use a torque wrench and tighten all the fasteners to the appropriate settings. The front flange and TORCA clamps should be tightened to **45 ft/lb** and the rear sway bar brackets to **49 ft/lb (UPPER)** and **70 ft/lb (LOWER)**.
16. It is strongly suggested that all clamps be checked and tightened after road testing the vehicle once the system has cooled.
17. **OPTIONAL:** Remove the fuse marked spare in fuse box under the passenger floor mat. This will disable the vacuum to the rear muffler that is no longer needed. **(See Fig. Y)**



FIG. X



FIG. Y