



## INSTALLATION INSTRUCTIONS

P/N: C2408

### 1979-93 MUSTANG BUMPSTEER ADJUSTER KIT

#### PARTS LIST

<u>QTY.</u>	<u>PART NO.</u>	<u>DESCRIPTION</u>
1	C2418200	BUMPSTEER SHIM KIT
2	C2408120	TAPERED STUD MUSTANG
2	C2408130	TIE ROD LINK 79-93 MUSTANG ANODIZED
2	C6010001	5/8-18 LH THREAD X 5/8 ID ROD END
2	0710109	5/8-18 LH THREAD JAM NUT
2	0710012	5/8-18 NYLOCK NUT
2	0708008	1/2-20 NYLOCK NUT
2	0808001	1/2 INCH FLAT WASHER

#### **This kit has the following outstanding features:**

- ❑ The tapered stud is precision machined to match the original equipment steering arm taper.
- ❑ Made from high strength 4140 material.
- ❑ Heat Treated for uniform molecular matrix.
- ❑ Does not require additional work of drilling of the steering arms.
- ❑ Wide range of adjustment.
- ❑ Tie rod links have Left Hand and Right Hand threads for easier toe adjustments.
- ❑ Less amount of installation time over the bolt style kits.

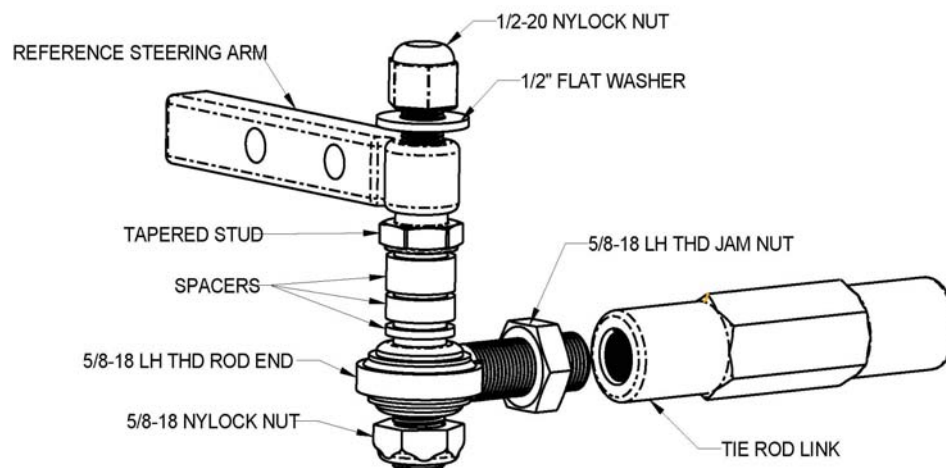

## **Bumpsteer Definition**

Bumpsteer is the toe-in change that occurs as the front suspension travels through its vertical movement. The vertical movement comes from; cornering causing body roll, braking and nose diving or hitting bumps in the road. The problem is a matter of geometry. As the front suspension goes through its vertical travel, there are a couple of arcs that are defined. One arc is the radius defined by the lower ball joint as it pivots around its chassis mount. Another arc is the one made by the outer tire rod end that is attached to the steering arm. It is pivoting off the rack and pinion ball joints. When a vehicle has its front suspension lowered, it effectively changes the factory geometry causing these two arcs to work against each other. Any differences in these pivot locations will result in bumpsteer which is a sudden change in toe-in during vertical suspension travel. Once for example you hit a "bump" the car "steers" somewhere other than where it was intended to go. The result is a car that darts from one side to the other, without any driver input into the steering. As the car goes faster, the effect becomes more violent.

This kit is designed to correct the inherent weaknesses in the factory front suspension effectively eliminating "bumpsteer."

Competition Engineering has developed this kit to correct bumpsteer, which allows you to shim the outer tie rod away from its steering arm mount to equal out the arc of travel with the lower control arm. We have also included a precision rod end and billet aluminum link to replace the failure prone factory tie rods and split sleeves.

**NOTE: RE-ALIGNMENT AND TOE-IN ADJUSTMENT IS MANDATORY AFTER INSTALLATION!**

## **INSTALLATION**

1. Raise and support the front of the vehicle with jack stands so you can work underneath it comfortably and safely.
2. Loosen the jam nut that locks the outer tie rod to the inner tie rod. Loosen just enough so the nut does not make contact with the outer tie rod. (Take care not to move this nut from this set position.)
3. Remove the cotter pin and nut holding the outer tie rod to the steering arm. Remove tie rod end from steering arm.
4. Hold the inner tie rod with a wrench to prevent it from spinning and un-thread the outer tie-rod until it comes off completely.
5. Thread the new aluminum tie-rod link from the bumpsteer kit onto the inner tie-rod until it contacts the jam nut.
6. Thread the new Left Hand Threaded Nut onto the new rod end and then thread the rod end, a minimum of 1 inch into the tie rod link. As close as possible match the length of the original outer tier rod that was removed earlier to the newly installed length.
7. Install the tapered end of the new tapered stud into the steering arm and install the 1/2" flat washer and 1/2" Nylock nut. Torque the nut to 40 ft lbs.
8. Repeat steps 2 thru 7 on the other side of the car.

9. The next steps are a process of trial and error. The primary intention is for the tie rods to be parallel with the lower control arms. Add equal thickness spacers to each straight portion of the installed tapered studs. Install the rod-end and lightly tighten the rod-end in place with the 5/8" Nylock jam nut.
10. Remove the vehicle from the jack stands and on level ground determine if more or less spacers are needed to make the tie rod parallel to the lower control arm.
11. Upon achieving the tie-rods parallel to the lower control arm, tighten and torque the 5/8" Nylock nuts of the bottom of the tapered studs to 50 ft-lbs. Tighten the jam nuts of each side of the tie rod links, on the passenger and driver side.
12. Bring the car to an alignment shop and align it according to the following instructions.

### **ALIGNMENT INSTRUCTIONS**

1. Set the car on an alignment rack (with moveable tables for the front wheels) and set the toe. You may also check your own toe settings by using Competition Engineering's Toe Plates P/N: C9600.
2. Next, compress the suspension a minimum of 1 inch. (This can be done with a come-along attached to the floor or alignment rack. Try to pull the car down evenly.) Measure the ride height with the suspension compressed and record this number. You will need to compress the suspension to this same height again later. Read the amount of toe at the new compressed height and again at normal ride height. Compare the two readings. **The object is to have the smallest possible change in toe between the at-rest and compressed suspension height.**
3. Record the spacers used each time. Rearrange the spacers and repeat step 2 from above. This is basically a process of trial and error until you achieve the smallest possible toe change. **It is important** to compress the suspension to the same height each time so an accurate toe reading will be recorded. **It is important** to make sure you compare the "at rest" and "compressed" readings to find the toe change each time you try a different arrangement of spacers. Do not directly compare the compressed toe recordings, because the at rest toe will change when the spacers are rearranged. It is the toe change in regards to the suspension movement you are trying to **minimize**. It is rare to achieve absolute zero toe change. We recommend arranging the spacers so that the car toe is out slightly when the suspension is compressed instead of toe inward.
4. Once you have the spacers arranged in their optimum position, reset the toe to the desired setting and check all fasteners to be secure.

We thank you for purchasing quality **MOROSO PERFORMANCE PRODUCTS**.