



## **INSTALLATION INSTRUCTIONS** **C2096 & C2100 SLIDE-A-LINK**

The Slide-A-Link by Competition Engineering is designed for use in Stock Eliminator and Bracket Racing vehicles. The rigid front mount assembly clamps around the leaf spring creating a positive displacement point for torque transmitted from the rear axle through the unique sliding link, cushioned by the urethane shock pad. Free travel and pre-load adjustments are made quick and easily on the vehicle by rotating the pre-load adjustment screw. Installation requires no welding or modification to the chassis or rear axle housing.

### **PARTS LIST**

- |                              |                              |
|------------------------------|------------------------------|
| 2) Rear Tube Assembly        | 2) Urethane Shock Pads       |
| 2) Slide Tube Assembly       | 2) Spring Clamp U-Bolts      |
| 4) 7/16"-14 Nylock Nuts      | 2) Front Spring Eye Bracket  |
| 2) Spring Pad                | 2) Pre-Load Adjustment Screw |
| 2) Aluminum Spring Bushing   | 4) U-Bolt                    |
| 2) 3/4"-16 Spherical Rod End | 2) Solid Rod End             |
| 2) Spring Eye Bushing Sleeve | 4) Rod End Spacer            |
| 2) 1-1/8"-12 Jam Nut         | 2) 5/8"-18x3" Bolt           |
| 8) 1/2"20 Locknut            | 4) 3/4"-16 Jam Nut           |
| 8) Washer                    | 2) 5/8"-18 Locknut           |
| 2) 3/4"-16x2-1/2" Bolt       | 2) 3/4"-16 Locknut           |
| 8) 1/2"-20 Unplated Nut      |                              |

Before beginning, this installation read the instruction sheet thoroughly.

### **INSTALLATION**

1. Raise the vehicle and support it on the frame with jack stands. Lower the rear housing so that the leaf springs are not supporting the chassis. Support the housing in place with jack stands and remove the rear tires.
2. With the weight of the housing supported, remove the leaf springs from the vehicle.
3. Un-bolt the front spring hangers and press out the stock bushings. You will need to do this in a hydraulic press. Press in the supplied aluminum Spring Eye Bushings. Make sure that there is an equal amount of bushing showing on each side of the spring eye. (See Fig. 1)
4. Lube the Spring Eye Bushing Sleeve with anti-seize paste and slide it into the Spring Eye Bushing.
5. Re-install the front spring hangers over the spring eye. Slide the supplied Front Spring Eye Bracket between the front hanger and the Spring Eye Bushing. The clamp end of the bracket should face away from the spring eye. (See Fig. 2)

6. Install the Spring Clamp U-bolt onto the front spring assembly using the 7/16"-14 Nylock nuts and tighten to 15 ft-lbs.
7. Mount the springs back into the vehicle. We recommend replacing the factory nut clips in the frame. These are available at most spring shops or the dealer.
8. Position the rear axle housing in place and install the supplied lower spring pad bracket. Use the U-bolts, washers and the 1/2" locknuts. Install the supplied 1/2"-20 unplated nuts onto the u-bolts before sliding them over the axle tube. Torque the locknuts to 70 ft-lbs. Tighten the unplated nuts against the axle bracket.
9. Install your shocks to the lower spring pad bracket.
10. Sliding Tube assembly procedure:
  - a. Install the solid rod end with jam nut into the front sliding tube (smaller diameter tube). Lube the threads with anti-seize. Make sure the rod end is threaded into the tube a minimum of 1". Tighten the jam nut securely.
  - b. Assemble the adjusting screw into the Rear Tube Assembly (larger diameter tube) so that it is threaded in approximately 2". Use anti-seize on the threads.
  - c. Thread the 1-1/8" jam nut onto the adjusting screw and tighten the jam nut.
  - d. Install the 3/4" jam nut onto the spherical rod end and thread it into the end of the adjusting screw. Use anti-seize on the threads. Make sure that the rod end threads into the adjusting screw a minimum of 1".
  - e. Hold the tube assembly at the welded nut with a wrench and tighten the 3/4" jam nut. At this time, loosen the 1-1/8" jam nut for adjustment later.
  - f. Lube the sliding tube with wheel bearing grease; slip the Urethane Shock Pad onto the sliding tube.
  - g. Slip the sliding tube into the Rear Tube Assembly. (see diagram)
11. Install the link assembly by mounting the solid rod end into the front spring eye bracket. Bolt it in place with the supplied 5/8"-18x3" bolt and rod end spacers lubed with anti-seize and a 5/8" locknut. Hand tighten at this time.
12. While holding the rear spherical rod end in one hand, rotate the rear tube assembly until the rod end lines up with the holes in the rear spring pad bracket. Slip a 3/4"x2-1/2" bolt through the holes. Install a 3/4" locknut and tighten to 75 ft-lbs.
13. Rotate the rear tube so that there is a 1/2" gap between the Urethane Shock Pad and the tube stop.
14. Tighten the front 5/8" bolt so that the nut just touches the bracket plus 1/2 a turn more. **DO NOT OVERTIGHTEN THE BOLT! THIS WILL CAUSE SUSPENSION BINDING!**
15. Check that all bolts are tightened correctly. Make sure that the 1-1/8" jam nut is loose and a 1/2" gap remains between the Urethane Shock Pads and one of the tube stops **BEFORE** lowering the vehicle to the ground.
16. Lower the vehicle to the ground.
17. Check for adequate Urethane Shock Pad gap. If you cannot rotate the rear tube by hand until a gap is present, raise one side of the vehicle at a time by the frame and rotate the tube. Repeat this process until a gap appears with the vehicle resting on all four wheels.

## **ADJUSTMENTS AND TUNING TIPS**

ALL ADJUSTMENTS MUST BE MADE WITH THE VEHICLE IN RACE READY CONDITION. THIS INCLUDES FUEL IN TANK, TIRE PRESSURE CORRECT AND DRIVER ON BOARD UNLESS OTHERWISE NOTED.

### Adjustments with corner scales

To get you started, you should add one turn of pre-load to both sides of the suspension without the driver on board.

- If you have access to scales that are capable of weighing all four corners of a vehicle, (most circle track chassis shops have these) you can more accurately set your pre-load. With the driver seated
- in the vehicle, add or remove preload on one side so that the weights of the rear tires are equal. Pre-load should not exceed four turns.

NOTE: A LARGE VARIATION OF PRE-LOAD FROM SIDE TO SIDE WILL CAUSE THE VEHICLE TO LAUNCH ERRATICALLY.

#### Adjustments without corner scales

1. With the vehicle on LEVEL ground, roll it back and forth in a straight line at least five feet. This is very important on vehicles equipped with a spool but is necessary for all types of limited slip differential vehicles.
2. Block the front and back of one of your front tires to prevent movement.
3. Rotate the driver's side rear tube until the tube stops makes contact with the urethane shock pad. Rotate the tube one additional turn to apply pre-load to the system.
4. Tighten the 1-1/8" jam nut while holding the welded nut on the rear tube with a wrench.
5. On the passenger side, rotate the rear tube until contact is made between the urethane shock pad and the tube stops. Rotate the rear tube an additional 1-1/2" turns. The extra 1/2 a turn helps to compensate for the driver's weight.
6. Tighten the 1-1/8" jam nut while holding the welded nut on the rear tube with a wrench.
7. Make one pass on the system, re-check all hardware, and repeat the pre-load adjustment procedure if necessary.

As with any racing component, continual inspection of the Slide-A-Link traction system is recommended. Re-lube the sliding parts every race to ensure proper operation.

#### Adjustments for Street Use

1. With the vehicle on LEVEL ground, roll it back and forth in a straight line at least five feet. This is very important on vehicles equipped with all types of limited slip differentials.
2. Block the front and back of one of your front tires to prevent movement.
3. Rotate the rear tubes until contact is made with the urethane shock pads and both tube stops.
4. Rotate the rear tubes in the opposite direction until a 1/4" gap is present between the urethane shock pads and the tube stop.
5. Tighten the 1-1/8" jam nut while holding the welded nut on the rear tube with a wrench.

For best performance at the racetrack, follow the race adjustment procedure. Return to the street settings before returning the vehicle to street use.

**C2100INST  
REV B  
(120299)**

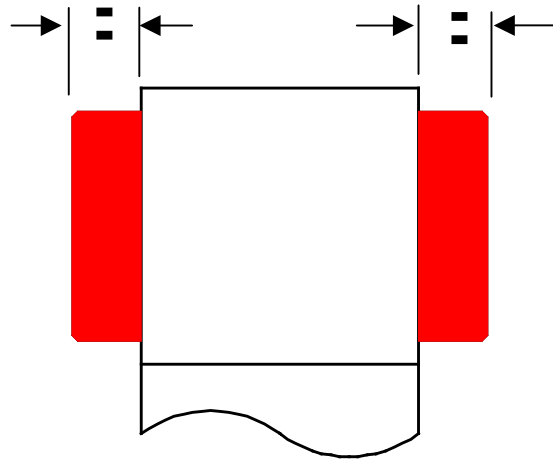

**FIGURE #1**

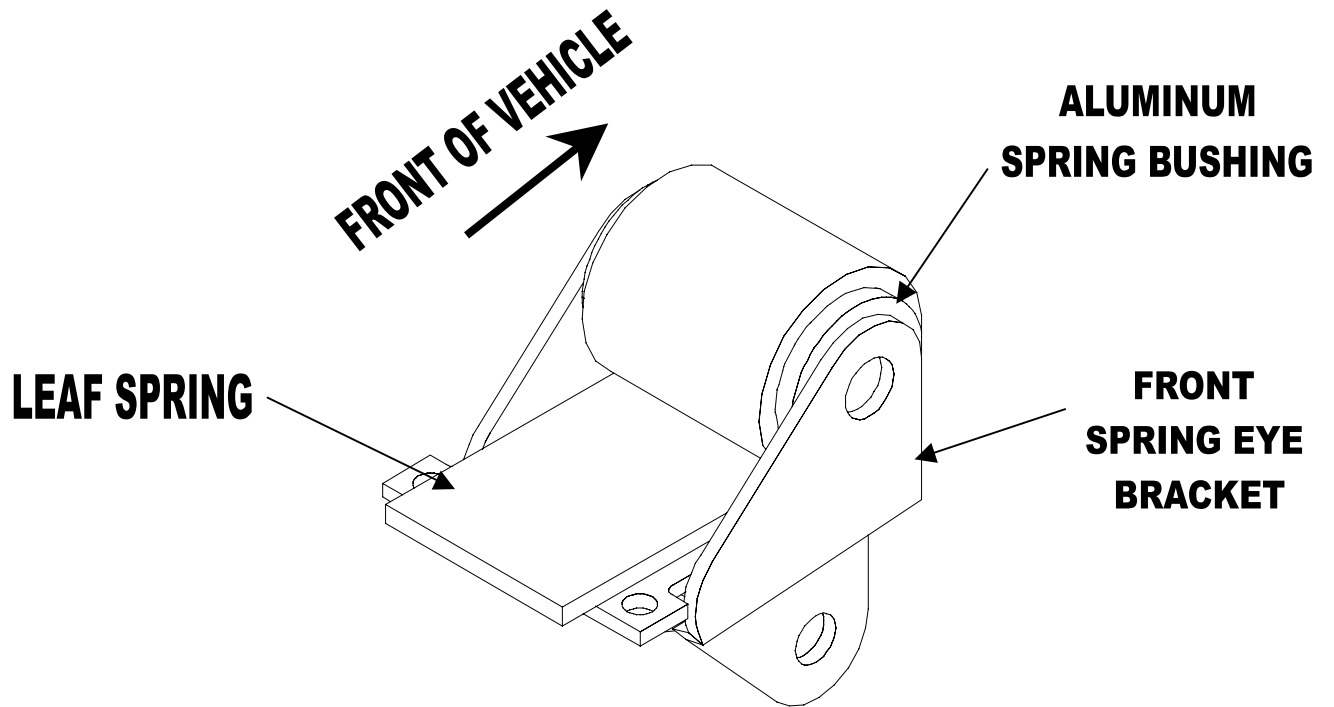

**FIGURE #2**

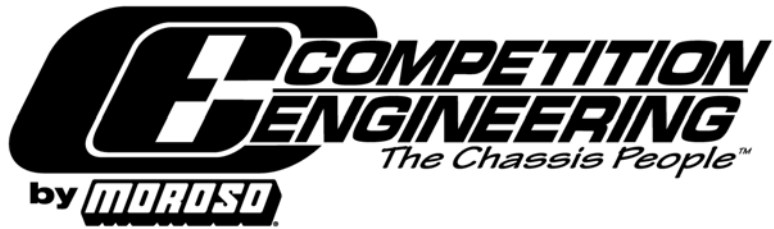

P/N C2199



Competition Engineering's New Slide-A-Link Wrenches (part # C2199) are manufactured from billet aluminum with large grip handles and are black anodized for corrosion resistance. This set includes two wrenches of the correct size to fit Competition Engineering Slide-A-Link adjustment nuts and can fit under your vehicle for easy adjustments in the staging lanes.

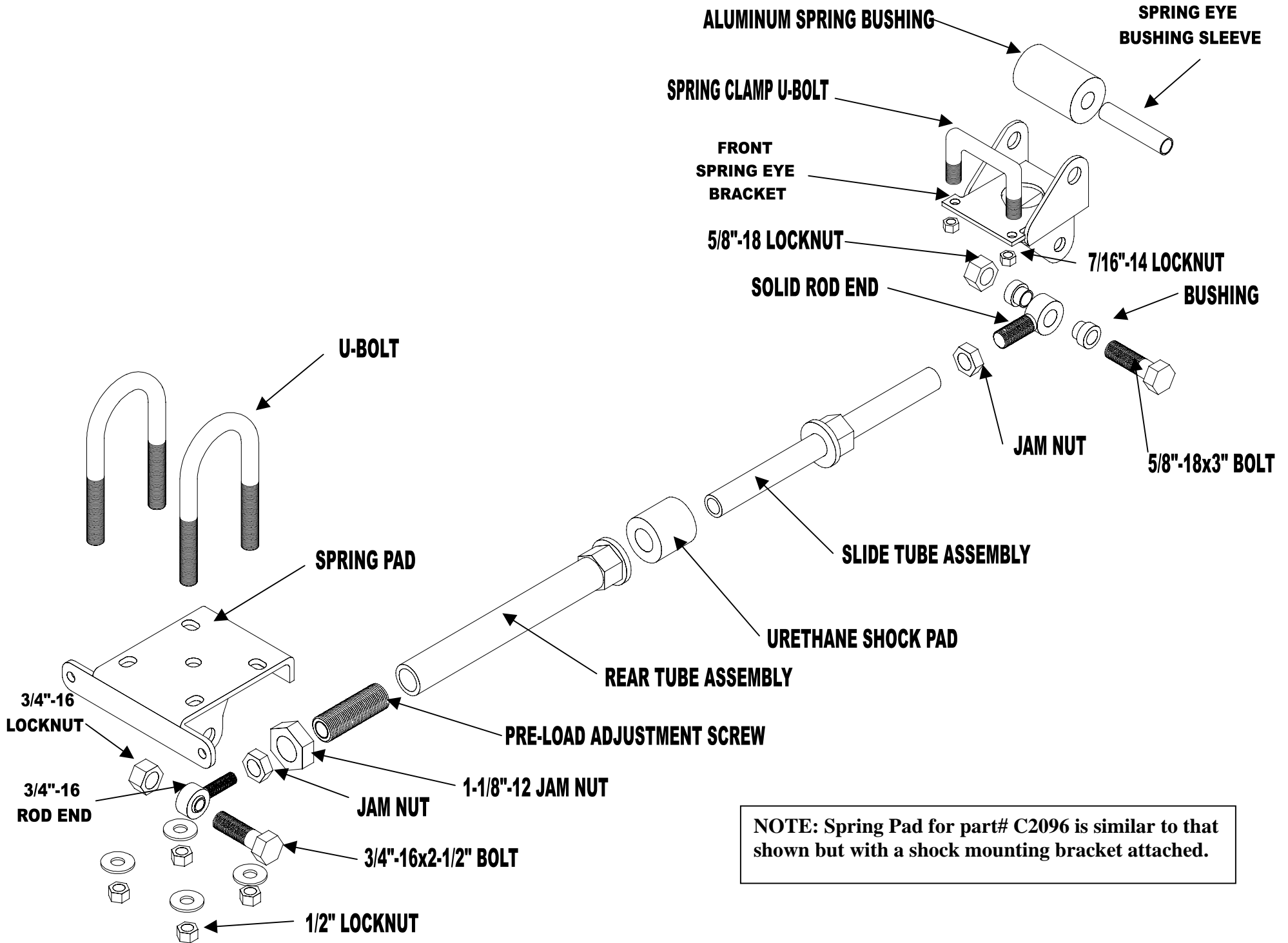

**NOTE: Spring Pad for part# C2096 is similar to that shown but with a shock mounting bracket attached.**