



INSTALLATION INSTRUCTIONS UNIVERSAL WELDED 4-LINK FRAME KIT

PARTS LIST

- | | |
|---|------------------------------|
| 1) Welded Subframe | 4) 4-Link Tubes |
| 4) 4-Link Axle Brackets | 1) Driveshaft Loop |
| 1) Coil-Over Spring Kit | 1) Bolt-On Diagonal Link Kit |
| 1) Lower Shock Mount Kit* | 4) 3/4"-16 Locknuts |
| 8) 3/4"-16 Bolts | 8) 3/4"-16 Locknuts |
| 2) 5/16"-18 x 1-3/4" Bolts | 2) 5/16"-18 Locknuts |
| Magnum Series Shocks or Coil Spring Mount Kit | |

* Magnum Series Shock equipped Frame Kits only.

Read all instructions completely before beginning the installation. The following suggestions will help to ensure a quality installation.

- All welding should be done using either the MIG or TIG process. A welding machine rated at 130 amps or higher should be used to ensure adequate weld penetration. All of the supplied components are made from mild steel unless otherwise noted.
- Select a clean, flat and level work area where the vehicle can remain undisturbed until final completion. The car cannot be moved once the rear frame and floor pan has been taken out.
- Trial fit all of the components several times, checking and re-checking all dimensions.
- Tack weld everything and double-check all your measurements before final welding.
- These instructions are only a guide to a correct installation. Certain applications may differ (Full Frame vs. Unibody, etc.) but the basic concepts used in chassis construction remain the same.
- Keep a fire extinguisher handy at all times during the construction process. Cutting torches, grinders and welding sparks can spark fires at any time.
- Cover all windows and gauges with cardboard to protect them from grinder sparks.
- **This kit requires the installation of at least an 8-Point Roll Bar. We highly recommend that a 10-Point Roll Cage be installed. Both 8-Point and 10-Point kits are available from Competition Engineering.**

TABLE OF CONTENTS

- I. Tool List
- II. Disassembly and Set-up
- III. Subframe Installation
- IV. Axle Bracket Installation
- V. Lower Shock Mount Installation
- VI. Housing Installation and Set-up
- VII. Diagonal Link Set-up
- VIII. Final Welding
- IX. Shock Assembly
- X. Final Assembly
- XI. Adjustments and Tuning Tips
- XI. Build Sheet
- XII. Diagrams

I. TOOL LIST

- Power Reciprocating Saw to remove floor pan and cut subframe to length.
- Body Grinder with coarse wheel to remove paint and rust.
- MIG or TIG welder with 130 amp minimum rating.
- Protective Face Shield for grinding and welding.
- Sheetmetal Shears to modify or remove interior panels.
- Tape Measure, Plumb Bob, Angle Finder, 3ft Level, Chalkline, Framing Square & Marking Pen.
- 4 Jack Stands and Floor Jack to support vehicle
- Cutting Torch to modify full framed chassis.

For a professional looking installation we highly recommend the following materials and tools:

- Thin cardboard to cover the windows. This protects the glass from welding and grinder sparks.
- Plasma Cutter for cleaner cuts when removing sheetmetal and frame components.

II. DISASSEMBLY AND SET-UP

1. Before beginning the installation, you must choose a place to work on the vehicle where it will not be disturbed until it is completed. The chosen area should be level, clean and preferably a solid surface, such as concrete.
2. At this time, remove all components that will be in the way of the removal and installation process. Items such as seats, carpet, wiring, door panels, gas tank, rear bumper and the deck lid should be taken off.
3. Take time now to cover all exposed glass with cardboard and tape. Also cover any gauges or radios to prevent damage from sparks.
4. Measure the wheelbase of the vehicle from the front spindle centerline to the rear axle centerline. Make sure that the front wheels are pointing straightforward. Mark this information down on the supplied build sheet at the back of this booklet.
5. Determine the desired ride height of the rear of the car. Measure from the floor to the bottom of the rearmost portion of the rocker box. Mark this dimension on the build sheet.
NOTE: Check your sanctioning body's guidelines concerning minimum ride heights.
6. Jack up the front and rear of the vehicle to a comfortable working height (approximately 24"). Support the vehicle under the front frame and the body in the rear using, as many jack stands as necessary to prevent the body from drooping when the rear frame is removed. A good location for the rear jack stands is under the rocker boxes, near the wheel opening.
7. Level the car using a 3-ft carpenter's level front to back and side to side. Take your time doing this, as this will determine how the subframe is finally located within the body shell. Use metal shims between the jack stands and the body/chassis to obtain proper level. It is recommended that braces be fabricated to support the rear tail panel of the vehicle. These can be made from 2"x4" lumber and mounted through the rear bumper bolt holes.
8. Remove the rear tires from the car.
9. Using the plumb bob, drop a point onto the floor from the front spindle center on each side of the car. Mark this point on the floor with the marking pen. Repeat this process to locate the front of the axle tube, marking the point on the floor.
10. Snap a chalkline between the two front spindle marks and the two rear axle marks. Using a straight edge and the marking pen, trace over the chalkline onto the shop floor, making the lines permanent.
11. Measure the diameter of the axle housing tube and divide it by 2. Write this dimension on the build sheet. Make a line; using this dimension, behind the line made for the axle housing. This is your rear axle centerline.
12. Measure from the front spindle line to the rear axle centerline and compare this dimension to the one on the build sheet. Note any differences.

13. Using the plumb bob, locate and mark the axle centerline onto the body with the marking pen. This will provide you with a quick reference when checking if the car has moved during construction. We highly recommend that you drop points onto the floor from fixed positions on the body to reference its position relative to the new chassis. Door to rocker pinch welds and front suspension brackets are the best places to use for reference points. Make sure you mark and circle the points so you can find them easily.
14. With all the critical dimensions taken, you may now remove the axle housing and any other unnecessary suspension components.
15. Determine the centerline of the vehicle and mark its location on the shop floor. This can be done as follows:
 - a. Measure the distance from one front spindle centerline to the other. Divide by 2. Write this dimension on the build sheet. Also mark this point on the line marked between the front spindle centerlines.
 - b. Drop a point from the inside of each rear frame rail onto the axle centerline. Measure between these points and divide by 2. Mark this point on the axle centerline and on the build sheet.
 - c. Stretch a chalkline between the two marks made in steps a & b. Snapping a line between these points gives you the chassis centerline.
 - d. Using a straightedge, make this line permanent by tracing over it with the marking pen.
16. Next we will determine the offset of the drivetrain. Most cars, but not all, have on-center drivetrains. You can figure this out as follows:
 - a. Measure from the center of the transmission tailshaft to the inside of the front frame rails on both sides.
 - b. Subtract one side's dimension from the other. The result will be the drivetrain offset.
 - c. Mark this point on the proper side of the chassis centerline in two places. Snap a chalkline between the two points and trace it with the straightedge and the marking pen. This line will be the centerline for the pinion. Write this dimension on the build sheet.
17. With the rear of the car down to the bare frame, determine where you want to cut the floor.
 - a. Measure forward from the rear axle centerline, along the chassis centerline, a distance of 26-7/8". Mark this location on the floor. Using the framing square, extend a line 90° from the chassis centerline at this point. Do this on both sides of the line extending it to approximately 30" per side.
 - b. Hold the string of the plumb bob against the floor pan over the line you just made on the floor. Center the point of the plumb bob over the line. Mark the location of the string on the floor pan. Do this in several locations across the floor pan, following the line on the floor.
 - c. Using a sharp punch or chisel, punch up through the floor pan on the marks you made from under the car.
 - d. Working from inside the car, connect the punch marks made through the floor pan with a marking pen and the straight edge. This will make the cut line for the front of the subframe crossmember. Extend this line so that it ends at the weld seam of the floor pan and the rocker box.
 - e. Cut out the floor pan using this line as a guide.
 - f. Remove all floor pan and trunk sheetmetal from this cut line back leaving the rear tail panel and package tray intact. Also remove the wheelwells being careful not to damage the quarter panel sheetmetal in the process.

18. With the floor pan removed, you can now cut off the unwanted section of the frame. Only cut what is necessary to clear the new subframe installation and your wheel/tire combination. Leave enough of the frame on full framed cars to allow for additional bracing between the old and new frames. Uni-body cars will have to connect the existing front subframe to the new rear subframe by way of a weld-in subframe connector. These are available from Competition Engineering.
19. With all the sheetmetal and frame removed, check that you have selected the proper width subframe by doing the following:
- Position the wheels and tires that you intend to use under the body of the car. Use concrete blocks or milk crates to position them at the desired ride height.
 - The sidewall of the tire should be a minimum of 1" from the wheelwell lip. The tire should be centered on the axle centerline.
 - Measure from the inside tire bulge of one wheel to the inside tire bulge of the other wheel. Subtract two inches to this dimension. This is your frame rail width. Write this dimension on the build sheet.
- Note: The wider you can make your frame rails, the better. Wider frame rails provide better top end stability and make it easier to mount your shocks and other brackets.

III. SUBFRAME INSTALLATION

- Trimming the crossmember:
 - Measure the distance between rocker boxes right behind the cut line made earlier. Divide this dimension by 2 and mark it on the build sheet.
 - Locate the center of the crossmember that is welded to the new subframe. Mark it with the pen. This is the line that will correspond with the chassis centerline. If you have an offset drivetrain, the line will match up with the drivetrain offset line.
 - Make a template to match the contour of the rocker panel where the 2"x3" crossmember will mount.
 - If you have no drivetrain offset, measure the distance determined in step a. on each side of the crossmember. If you do have drivetrain offset, make sure to subtract the offset from one side and add it to the other. Example: Rocker-to-rocker dimension = 50", Drivetrain offset = 1" to the passenger side, $50" \div 2 = 25"$ per side, $25" - 1" = 24"$ passenger side crossmember length, $25" + 1" = 26"$ driver side length. The centerline of the crossmember should remain inline with the drivetrain centerline.
 - Using the template, trim the ends of the crossmember to the desired length.
- Determining frame rail length:
 - With the location and ride height of the front crossmember determined, measure from the face of the crossmember to the intended mounting location of the rear of the subframe. This location will be located somewhere on the rear body panel. Write this dimension on the build sheet. As shipped, the length of the subframe from the face of the crossmember to the end of the top rail is 69".
 - Determine the desired height location of the rail ends on the body panel. As shipped, the top of the frame rail ends are 14-3/4" above the top of the front crossmember. Measure from the floor to the desired mounting point on the rear body panel. Write this dimension on the build sheet.

Note: With the crossmember at the recommended 8" ride height, the bottom of the frame rail is 26" above the floor.

- c. To determine the proper length of the frame rails, subtract the as-shipped length (69") from the dimension determined in step a. Write this dimension on the build sheet.
 - d. Cut the frame rails to the proper length at this time.
3. With the help of a friend, position the new subframe under the body. Align the centerline mark on the crossmember with the chassis centerline on the floor. Support the subframe in place with jack stands and wood bracing. Trim the rails as necessary to ensure a snug fit.
 4. Level the subframe side-to-side and front-to-back using the 3ft level. Draw a line 2" behind the previously-made front crossmember line. Using the carpenter's square, check to see if the crossmember line is perpendicular to the chassis centerline.
 5. Drop plumb bob points off the back of the crossmember down to the line on the floor. Adjust the position of the subframe until it aligns perfectly with the new line on the floor.
 6. When the crossmember and the chassis centerline are aligned, tack the ends of the crossmember to the rocker boxes.
 7. It may be necessary to fabricate reinforcing brackets from the rear body panel to the subframe for strength. Do not weld in one continuous bead when attaching the rear of the subframe to the body panel. Severe warpage and burn through will result. Instead weld in 1/2" long beads, alternating from rail to rail, giving time for the metal to cool sufficiently. Remember to tack weld the subframe in place first. Final welding will be done at the completion of the project.
 8. You may now install your subframe connectors, tying them into the front of the new crossmember. For full frame cars we recommend adding diagonal bracing from the stock frame to the front of the new crossmember.

With the subframe tacked in place, we will now move on to modifying the axle housing.

IV. AXLE BRACKET INSTALLATION

1. Using the plasma cutter or cutting torch, remove all existing factory brackets from the axle housing you intend to use. Be careful not to add too much heat to the housing, as it will warp the tubes, causing problems later.
2. Remove the housing ends as close to the welds as possible using a bandsaw or abrasive chop saw.
3. Measure the distance between the front chassis brackets and write this dimension on the build sheet.
4. Assemble the 4-link axle brackets using your rod ends as spacers.
5. Slide the axle housing brackets onto the axle tubes so that the flat edge of the brackets face forward and the link mounting holes closest to the axle-mounting hole are on top.
6. Align the brackets so that they are equally spaced from the pinion centerline for centered drivelines. For offset drivelines, make sure you offset the pinion the same amount as the driveline.
7. Tack weld the brackets so that they are 90° to the pinion. Place tacks in three places around each bracket to ensure that they do not move.

V. LOWER SHOCK MOUNT INSTALLATION

Subframe kits that have the Magnum Series coil-over shocks also include a separate lower shock mount kit. Coil spring mount equipped kits have the lower shock mount packaged with the coil spring mount kit. The installation procedure is the same for both.

1. Assemble the lower mounting brackets to the axle brackets using one right hand bracket and one left hand bracket per side. (See Diagram) Use the provided 3/8"-16 bolts and locknuts to attach them. Do not tighten completely at this time. Mount these brackets in the middle of the axle brackets to allow for up or down ride height adjustment.

2. Measure the center-to-center distance between the upper shock mount brackets located on the subframe. Write this dimension on the build sheet.
3. The lower axle brackets should be mounted equally distant and perpendicular to the pinion centerline at the dimension determined in the previous step. Make sure that they are parallel to each other.
4. With everything in place, tack weld the brackets to the axle tubes. Re-check the mounting dimension and that the brackets are square to the pinion.

VI. HOUSING INSTALLATION

1. Assemble the 4-link tubes with the rod ends of your choice. Thread the jam nuts onto the rod ends so that approximately 1" of thread is showing. Thread the rod ends into the link tubes and adjust them equally to achieve a distance of 21" center to center.
2. Using a floor jack, slide the housing under the newly installed subframe.
3. Install the link tube assemblies into the chassis and axle brackets using the supplied 3/4" hardware.
DO NOT INSTALL THE PASSENGER SIDE UPPER BAR AT THIS TIME.
4. Swing the housing upward so that the distance between the upper and lower shock mounting holes is 13-3/4". Support the housing with the floor jack.
5. Check your wheelbase on each side using the dimension from the build sheet for reference. If the wheelbase needs to be adjusted, rotate the lower 4-link bars to achieve the correct dimension. Once the correct measurement has been reached, tighten the jam nuts.
6. Using an angle finder, check the pinion angle by placing it against the mounting surface of the center section (Mopar 8-3/4" and 9" Ford) or the rear cover surface (10&12 Bolt GM, Dana, Ford 8.8 etc.).
7. Rotate the driver's side upper 4-link bar to achieve 1°-2° downward pinion angle. Lock the jam nuts in place.
8. Install the passenger side upper bar at this time. This bar should be installed so that the bolts slide in without resistance. Do not force the bolts or move the housing to get them to fit. Instead, rotate the link to achieve the proper length.

NOTE: Forcing the bolts into place will cause the chassis to be pre-loaded. This will cause problems later down the road when it comes time to tune the chassis.

9. Re-check the wheelbase on each side, adjust as necessary. If you make changes to the wheelbase, be sure to check the pinion angle and the pre-load bar.
10. Label the mounting locations of the link tubes using masking tape and a marking pen. This will ensure that they go back in the right place.

VII. DIAGONAL LINK SET-UP

1. Remove the lower bolt located on the driver's side chassis bracket.
2. Slide the bolt through one of the supplied link brackets and replace it into its mounting hole. The ears of the bracket should be facing the driveshaft and be parallel to the ground. Re-install the nut on to the bolt, but do not tighten.
3. Repeat this process for the passenger side lower hole located on the axle bracket.
4. Thread the left-hand jam nut onto the left-hand rod end. Thread it approximately 3/4 of the way up the rod end threads. Repeat this process for the right hand rod end.
5. Install the rod ends into the link brackets with the supplied 1/2"-20 bolts.
6. With the threaded portions of the rod ends facing each other, measure the distance from one jam nut to the other. This will be the finished length of the tube. Write this dimension on the build sheet.

7. Cut the tube to match the dimension. Make sure that you cut off material from the right hand threaded end of the tube. Re-tap the cut end of the tube with a 1/2"-20 right-hand thread tap. This tap size can be purchased from any hardware store.
8. Remove the rod ends from the brackets and thread them into the end of the tubes. We highly recommend using anti-seize compound on the threads to eliminate galling and thread damage.
9. Install the bar assembly into the mounting brackets.
10. Using the plumb bob, locate the pinion centerline directly over the chassis centerline. This can be accomplished by rotating the diagonal link in either direction to shift the housing in the proper direction. Tighten the jam nuts at this time.
11. Remove the 4-link tubes as well as the diagonal link at this time.

VIII. FINAL WELDING

Now that everything is fitted and in place you can begin the final welding process. We will begin with the welding of the subframe, then the axle housing and ending with the roll bar. Remember to take your time. If a tack weld breaks, re-tack it before proceeding. Alternate your welds from one end of the part to the other. This will prevent twisting and excessive movement of the welded part. When welding on the axle housing, the use of an alignment bar is highly recommended.

NOTE: WE HIGHLY RECOMMEND THAT YOU INSTALL YOUR ROLL BAR OR ROLL CAGE AT THIS TIME TO ELIMINATE SHIFTING OF THE SUBFRAME.

1. With the rear housing moved out of the way, begin to add secondary tacks to all the areas that are to be welded. Place the tacks in locations that will be the beginning and end of a weld bead. This will ensure a cleaner looking weld.
2. With all the secondary tack welds in place, begin to weld the subframe to the car. Weld each end of the crossmember first, then proceed to the rear of the frame rails. Next, weld the subframe connectors to the face of the crossmember and then to the front subframe.
3. Weld the floor pan to the front of the crossmember using a stitch technique to eliminate burn through.
4. Prepare the rear axle housing for final welding.
5. Insert the alignment bar through the housing using bushings in the axle tubes and center section to hold the bar centered within the housing.
6. Weld the brackets to the axle tubes using the same alternating weld technique to minimize warpage. Allow the welds to cool periodically, this will also help to reduce warpage.
7. With the brackets welded completely, install your choice of housing ends at this time. Remember to keep the alignment bar in the housing during the installation of the housing ends. The bar should be left in until the housing is completely cool.

IX. SHOCK ASSEMBLY

The following instructions cover the assembly and installation of the Magnum Series Coil-Over Shocks and the Coil Spring Mount Kit.

Magnum Series Coil-Over Shock Assembly:

1. Clamp the lower mounting loop in a large vise. (Use of soft vise jaws is recommended to protect the aluminum housing from scratches etc.)
2. Screw the aluminum spring seat and jam nut down to the last thread, NO FURTHER. Now is a good time to lubricate the threads of the shock body with an anti-seize lubricant.
3. Pull the piston rod all the way out and slide the bump stop down. Check the jam nut under the upper bearing housing making sure it is secure.

4. Slide the spring over the shock body. Slip the spring cap in place, making sure that it is set in the spring squarely. The spring rate selected for your application will determine how difficult they will be to install.
5. Adjust the spring seat up until the spring is compressed 1 inch shorter than the free height of the spring, i.e. 12-inch spring would be compressed to 11 inches. This preloads the springs prior to mounting on the vehicle. (Make sure that the spring cap is aligned properly under the upper bearing mount)
6. Bearing Installation:
 - a. Test fit the bearings in both ends of the shock. Bearings may start easier on one side than the other.
 - b. Clean the outer bearing race with solvent and apply thread-locking compound to the outer bearing race and the bore surface of the bearing mount.
 - c. Assemble by inserting the bearing in a twisting motion. Install the snap rings on both sides of the bearing. (In some cases it may be necessary to press the bearings into the mount.)

Coil Spring Shock Mount Kit Assembly:

1. Place the rear housing in its proper position and at the correct ride height.
2. Mount the lower shock brackets to the weld-on axle brackets using the supplied 3/8"-16 hardware.
3. Install the spring and the spring perches on the top and bottom of the coil-over spring. Slide the spring assembly over the shock absorber and over the upper and lower mounting tabs. Fasten in place using the supplied 1/2" bolts. Tighten the 1/2" bolts to 65-ft/lbs and the 3/8" bolts to 40-ft/lbs.

X. FINAL ASSEMBLY

1. With the subframe securely welded to the car and the axle housing welded complete; begin to re-assemble the rear suspension.
 - a. Slide the housing assembly under the chassis and locate it in place using your marks on the floor.
 - b. Install the assembled 4-link bars into the appropriate holes in the chassis and axle brackets.
Remember the lower links go in the bottom holes of the chassis and axle brackets and the top links go in the top holes on the axle brackets and the middle holes on the top of the chassis brackets. Do not put the passenger side upper bar in at this time. Make sure that you put the labeled bars in their correct positions.
2. Install the diagonal link in position but do not tighten the jam nuts at this time. Make sure that the mounting brackets are parallel to the shop floor.
3. Mount the assembled Magnum Series Shocks into the upper and lower shock mount brackets using the supplied 1/2"-20 x 2-1/2" bolts and locknuts.
4. Slide the driveshaft hoop over the welded stubs on the crossmember. Drill through the center of each hoop leg approximately 1" from the end using an 11/32" drill bit. Install the supplied 5/16"-18 x 1-3/4" bolts and locknuts.

XI. ADJUSTMENTS AND TUNING TIPS

The following procedure should be done with the vehicle's weight resting on the housing. Support the axle housing with jack stands.

1. Adjust the coil-over spring seat up or down to reach the desired shock ride height. Shock ride height is the distance from the center of the top-mounting loop to the center of the bottom-mounting loop. If you have selected the proper spring rate, you should be able to adjust the spring seat up or down approximately 1/2" to get into the recommended ride height. If you cannot achieve the shock ride height recommended, a softer or stiffer spring may be required.

2. Check the vehicle ride height using the calculation found on your build sheet. Vehicle ride height should be changed if the car sits higher or lower than desired. With the chassis supported with jack stands, unbolt the adjustable lower shock mount brackets and move the housing up or down to get the vehicle ride height you are looking to achieve. When this is accomplished, place the vehicle's weight back on the axle housing supporting it with jack stands.
3. Using the plumb bob check the alignment of the housing in relation to the centerlines on the floor. Rotate the diagonal link in either direction to center the housing under the chassis. Lock the jam nuts when you are finished.
4. Check the wheelbase on each side of the car using the dimensions on your build sheet. Adjust the lower bars to achieve the correct dimension.
5. Adjust the pinion angle by turning the driver's side upper bar so that the angle finder reads 1-2° downward angle.
6. Install the passenger side upper bar so that the mounting bolts slide through the brackets without resistance. Do not force the bolts. Lengthen or shorten the link bar to allow the bolts to go through.
7. Tighten all jam nuts and mounting bolts.
8. The installation of your 4-link Subframe Kit is now complete. At this time you can install your fenderwells and tinwork as well as your axles, center section and wheels.

TUNING TIPS

Magnum Series Shock Adjustment:

1. Competition Engineering Magnum Series Coil-Over Shocks have 12 damping settings. There are 4 clicks per revolution of the knob. The knob will rotate 3 times. Do not adjust past the 12th click. Base settings to start testing with are 3-5 clicks for bracket racing and 4-7 clicks for Pro Tree racing. THESE ARE BASELINE SETTINGS. NOTE: DO NOT FORCE THE ADJUSTER KNOB. DO NOT USE PLIERS OR ANY OTHER TOOLS ON THE ADJUSTER KNOB. DO NOT EXCEED 12 CLICKS UNDER ANY CIRCUMSTANCES. THIS COULD DAMAGE THE IDLER PIN AND CAUSE THE SHOCK NOT TO ADJUST. THIS WILL VOID ALL WARRANTIES.
2. The ride height can be adjusted by raising the chassis and supporting it with jack stands. With the rear axle housing supported by a floor jack, raise or lower the axle mounting brackets the desired amount.

CAUTION: NEVER ATTEMPT TO MAKE A SUSPENSION ADJUSTMENT WITHOUT FIRST SUPPORTING THE CAR WITH JACK STANDS.

Coil Spring Mount Adjustment:

1. With the shock removed from the vehicle, compress it fully.
 2. Rotate the top of the shock until you feel the internal adjuster engage.
 3. Rotate the shock in a clockwise direction, listening for three distinct clicks. There will be one loud click followed by two softer clicks. This will repeat three times around the shock. The loud click is the "R" or regular setting, the first soft click is the "F" or firm setting and the second soft click is the "XF" or extra firm setting.
 4. Re-install the shock after the desired adjustment has been set.
- If the car pulls to the right on launch, you can shorten the passenger side upper bar up to one wrench flat at a time. If more than two wrench flats are added you should look for signs of suspension binding or flex.
 - If you run into trouble while tuning always go back to your baseline set-up. Keep your build sheet in a place where it won't get lost and refer to it when making changes.

- Change one thing at a time and try it before changing something else. Too often racers change several things at once not knowing what thing made the car run better or worse. Keep a log of all changes.
- Lowering the instant center (the imaginary intersection point of the top and bottom bars) will reduce weight transfer and soften the hit on the tires.
- Raising the instant center will increase weight transfer and hit the tires harder.
- Always check the pinion angle when relocating the links on the brackets. Strive to keep 1-2° downward pinion angle.
- Check your mounting bolts before each race making sure they are tight. Keep your rod ends clean and oiled. Take the suspension apart each year to clean and re-oil the rod ends. Look for mechanical bind as well as bent or cracked brackets and welds.

BUILD SHEET

Driver's Side Wheelbase = _____ Passenger Side Wheelbase = _____
 Desired Ride Height = _____ Axle Housing Diameter / 2 = _____
 Front Spindle Center to Center / 2 = _____ Rear Framerrail to Framerrail / 2 = _____
 Drivetrain Offset = _____ New Framerrail Width = _____
 Rocker Box to Rocker Box / 2 = _____ New Framerrail Length = _____
 Floor to Rear Body Panel Mounting Point = _____
 Amount to Cut Off Frame Rail = 69"- New Framerrail Length = _____
 Distance Between the Front Chassis Brackets (Inside to Inside) = _____
 Center to Center Distance Upper Shock Mounts = _____
 Diagonal Link Length = _____ Tire Size = _____
 Pinion Angle = _____ Rear Spring Installed Height = _____
 Spring Rate, Rear = _____ Shock Valve Setting = _____

RIDE HEIGHT FORMULA

$DR-(TD/2) = \underline{\hspace{2cm}}$ (HD height difference), $AJ-RJ = \underline{\hspace{2cm}}$ (CH construction height)
CH-HD = AMOUNT TO RAISE OR LOWER SHOCK MOUNTS FOR CORRECT RIDE HEIGHT

VEHICLE WEIGHT SPECIFICATIONS

Total Weight = _____
 Front Weight = _____
 Rear Weight = _____
 Left Front Weight = _____
 Right Front Weight = _____
 Left Rear Weight = _____
 Right Rear Weight = _____
 % of Weight, Front $(LF+RF/Total \times 100) = \underline{\hspace{2cm}}$
 % of Weight, Rear $(LR+RR/Total \times 100) = \underline{\hspace{2cm}}$

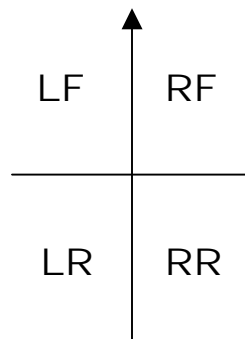

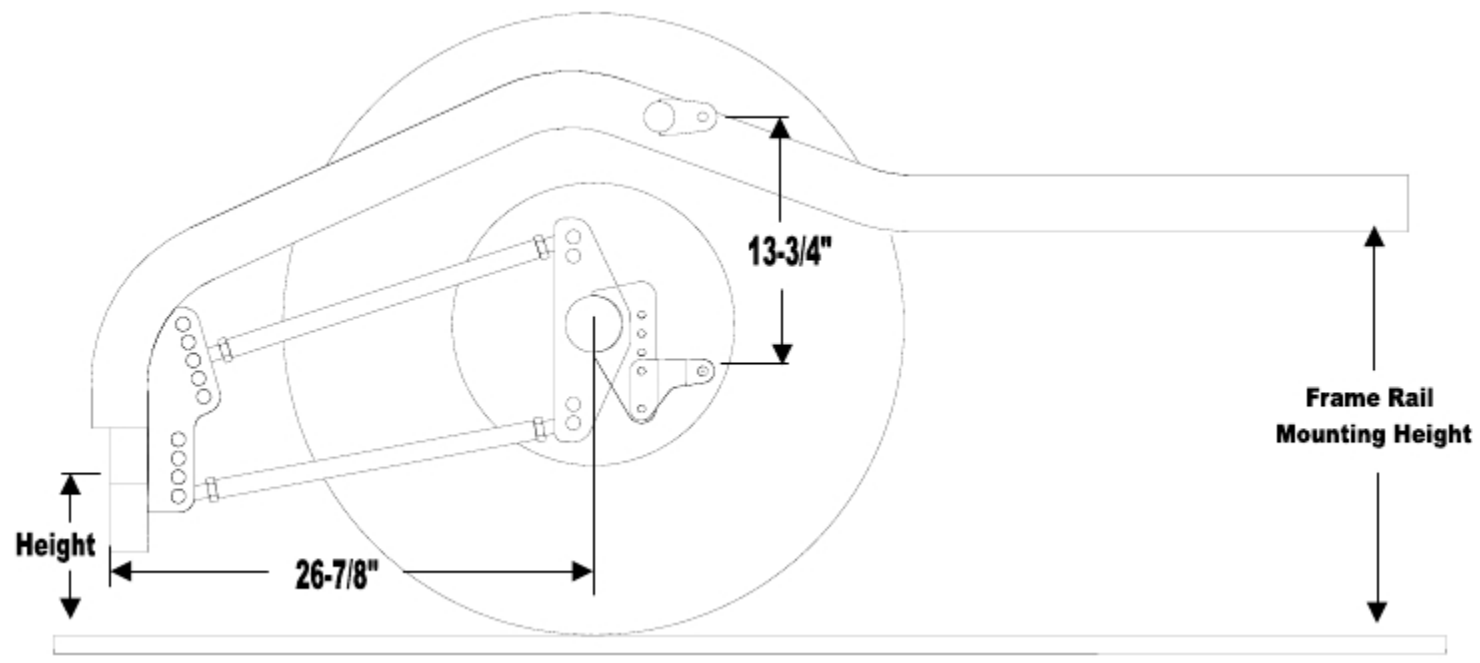

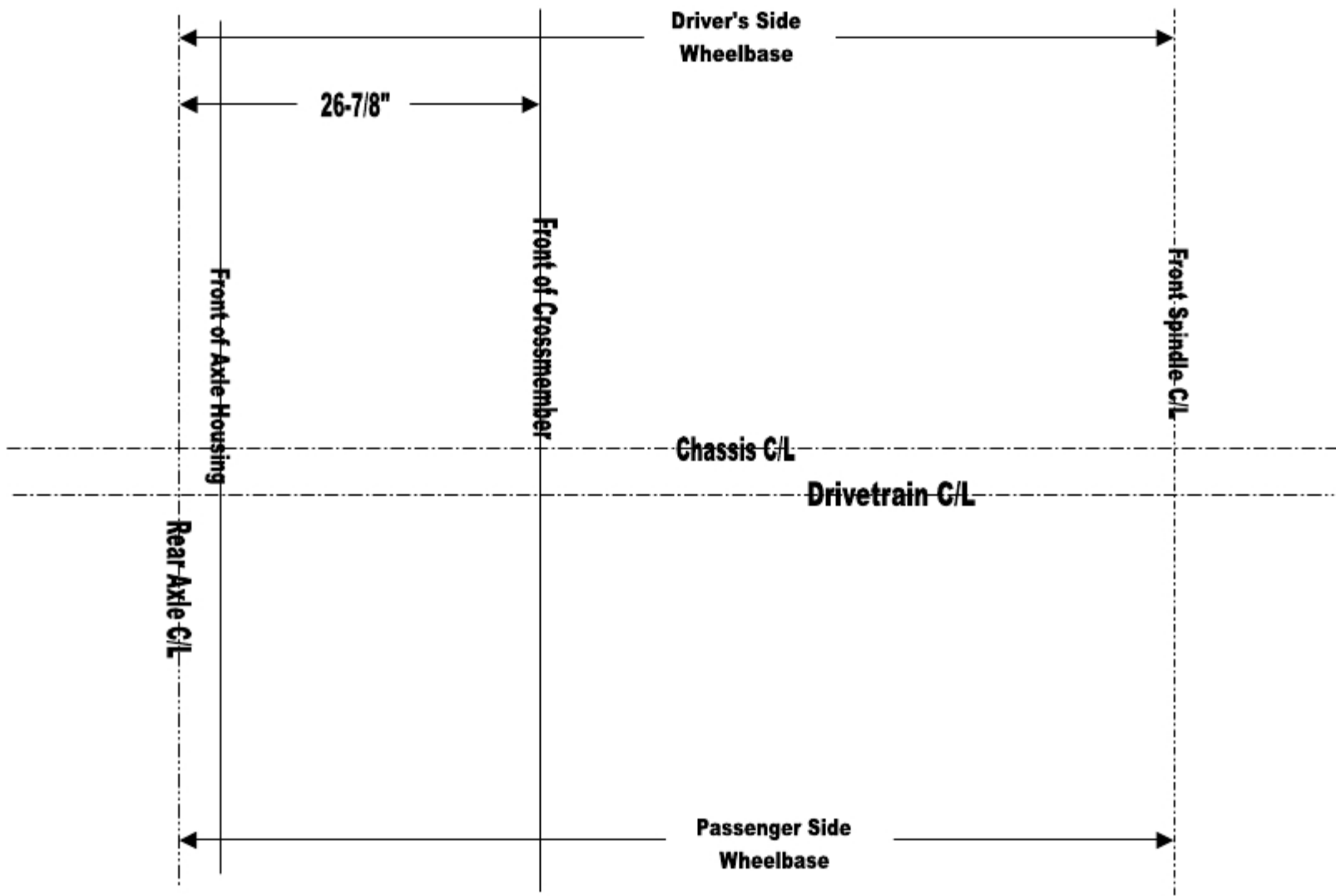

Floor Centerline Diagram