

INSTALLATION INSTRUCTIONS FOR THE UNIVERSAL THERMOSTATICALLY CONTROLLED ELECTRIC FAN RELAY KIT

Be sure to route wires in a manner so that they do not chafe on any sharp metal edges and use proper terminals and connectors at all connecting points to insure proper electric fan function. This fan control kit can be used with single fan or multiple fan applications as long as the combined current draw does not exceed 30 amps.

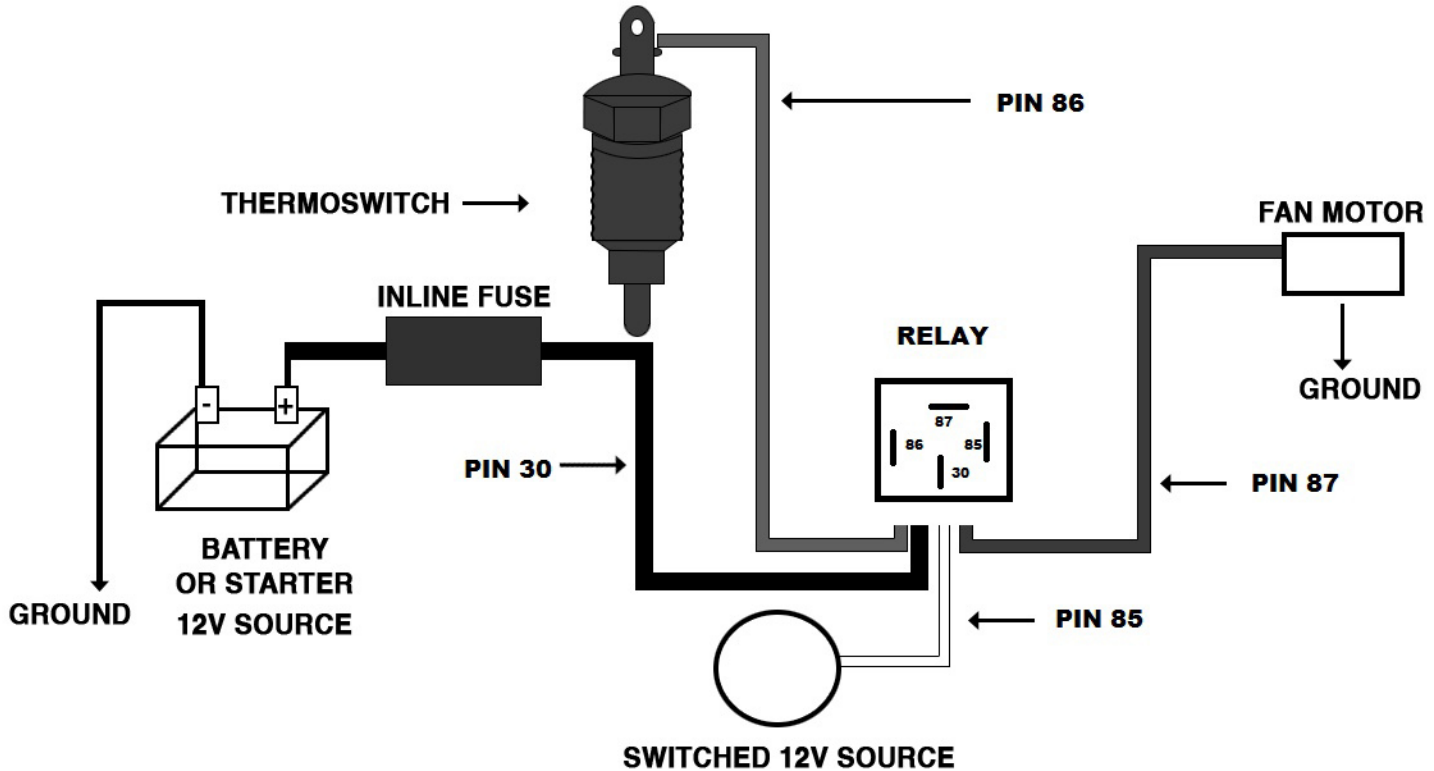

1. After you have mounted and installed your Cold-Case radiator and fan package, you will need to start the wiring of your EF-1.
2. Start by finding a good spot to mount the relay.
3. Locate the port in the intake manifold to thread the thermoswitch into. You may need to use the supplied adapter depending on size. You will want to use a little sealant on the threads we recommend liquid Teflon sealer.
4. Route pin 30 wire directly to your battery. You will need to add the inline fuse to this wire. You will use butt connector and eyelet to do this.
5. Route pin 86 wire to thermoswitch, making sure it is clear from exhaust and other moving parts. You will need to trim this to length and add eyelet to attach to thermoswitch.
6. Route pin 87 wire. This will be spliced to red wire from fan harness. Trim to correct length and splice together using butt connector.
7. You will need to locate a switched 12v source. You will need to attach the wire from pin 85 to this.
8. Make sure all grounds have a good clean contact to frame.

WIRING SPECS

Fans are temperature controlled and turn on at 190 degrees.

Amp Draw: 16" fan (6-8 amps) and Dual 12" fans (12 amps)