



INSTALL INSTRUCTIONS:
 2017-2019 Ford F250/F350 Super Duty,
 SM Limited Dynamic Geometry
 Traction Bar Kit, 0-4.5" Rear Lift Height
 SKU: 120-90471

PARTS LIST FOR SKU: 120-90471		
QTY.	PART #	DESCRIPTION
2	8521	45" Boxed Sheet Metal Traction Bar
1	8560	17-19 FSD Frame Mount Bracket 0-4.5" Driver Side
1	8561	17-19 FSD Frame Mount Bracket 0-4.5" Passenger Side
2	8520	FSD Axle Mount Bracket
4	8460	6" Traction Bar Shackle
1	HP9169	Ford Traction Bar Hardware Kit
1	HP9214	Traction Bar Bushing Kit



HP9169 – Ford Traction Bar Hardware Kit		
QTY.	PART #	DESCRIPTION
2	6079G	Black Polyurethane Bump-Stop
2	H-93305	Socket Head Cap Screw 3/8"-16 UNC x 1.00 Lg.
4	H-15207	Cap Screw 1/2"-13 UNC x 1.25 Lg.
4	H-15212	Cap Screw 1/2"-13 UNC x 2.25 Lg.
2	H-15269	Cap Screw 9/16"-12 UNC x 4.00 Lg.
2	H-15273	Cap Screw 9/16"-12 UNC x 5.00 Lg.
2	H-33082	3/8" SAE Flat Washer
16	H-33086	1/2" SAE Flat Washer
8	H-33088	9/16" SAE Flat Washer
2	H-37264	3/8"-16 UNC Lock Nut
8	H-37268	1/2"-13 UNC Lock Nut
4	H-37270	9/16-12 UNC Lock Nut

HP9214 - Traction Bar Bushing Kit		
QTY.	PART #	DESCRIPTION
8	2581.01-MOD	Black Polyurethane Bushing
4	2509.1	Black Polyurethane Spring Bushing
4	5036	.75 x 1.035 x .50 Crush Sleeve
2	5045	1.00 x .219 x 3.27 Crush Sleeve

8521 – 45" Boxed Sheet Metal Traction Bar		
QTY.	PART #	DESCRIPTION
2	6208	Giro Bushing
2	6227	1-1/4"-12 UNF Forged Rod End
2	6229	Traction Bar Adjuster Nut
4	H-93307	Socket Head Cap Screw 3/8-16 UNC x 1.25 Lg.
4	-	3/8" Steel Split Lock Washer

WARNING

Please read this entire instruction sheet before beginning installation. Proper installation of these components requires a qualified mechanic. Always wear safety glasses when using power tools, and take appropriate precautions when working under a vehicle. If these instructions are not properly followed you may jeopardize your, and your passenger's safety, and severe frame, suspension or tire damage may also result from improper installation.

INTRODUCTION

Traditionally traction bars have a fixed length and fixed front pivot point. The nature of a leaf spring is to bend in order to do its job of carrying vertical load. When the spring is bending, the distance between the fixed front pivot bolt of the spring, and the axle housing, changes through the suspension cycle because the leaf spring is bending to do its job. A fixed length traction bar coupled with a leaf spring that is changing length causes binding as the axle travels in the suspension cycle. The Cognito Limited Dynamic Geometry traction bar kit allows the length of the traction bar and shackle assembly to vary with the leaf spring through the suspension cycle under normal operating conditions, without binding via the use of the shackle. The length of the traction bar assembly at its longest position, which is when the shackle is lined up with the traction bar, is used to control axle wrap and wheel hop that can happen when high torque loads are applied by heavy acceleration and/or heavy weight loads.

REQUIREMENTS

- This installation requires a qualified mechanic.
- A vehicle lift is required to perform the installation of these products and always ensure the vehicle is properly supported before attempting installation or serious injury may occur.
- Read instructions carefully and study the pictures before attempting installation.

TECHNICAL INFORMATION

- Check the parts and hardware packages against the parts list to assure that your kit is complete
- Each lift kit, and options to lift kits, are packaged separately. Therefore installation procedures are covered in separate instructions. Familiarize yourself with each specific set of instructions before beginning.
- Follow the OE specifications when replacing or re-installing OE fasteners, retainers, and hardware specified in the OEM manual.

INSTALLATION

Figure 1: Fuel Tank Stone Deflector



Figure 2: Brake Cable Bracket Mounting Bolt



1. On the driver side frame rail, remove the fuel tank stone deflector (Figure 1). Then remove the brake cable bracket mounting bolt, labeled in (Figure 2). Once the brake cable bracket is removed, release the lower brake cable from the saddle and hang freely (Figure 3). Ford F250/F350 Platinum edition super duty trucks may require removing an auxiliary fuel cell stone deflector under the fuel cell. Trim accordingly, once this installation has been completed to re-install.

Figure 3: Brake Cable Removed



Figure 4: Frame Mount Bracket

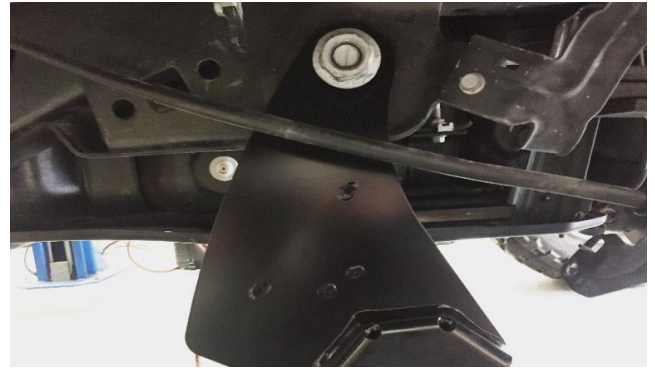

2. Before starting step 2, raise the vehicle or support rear axle housing at a position so the leaf spring is free of tension. Remove the front leaf spring pivot nut and align the 17-19 FSD Frame Mount Bracket 0-4.5" Driver Side (Part # 8560) so the frame mount bracket is between the frame and pivot nut (Figure 4). Replace the leaf spring pivot nut to hold bracket in position, but do not tighten at this time.

Figure 5: Frame Mount Bracket Alignment



Figure 6: Frame Mount Hole Locations

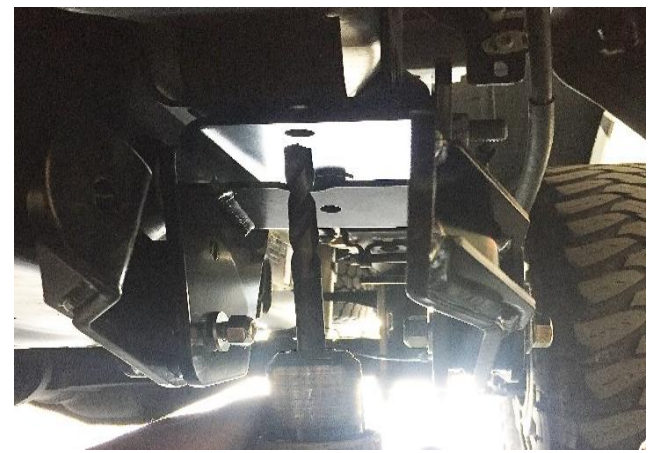

3. Rotate the frame mount bracket forward until the front mounting hole sits on the frame rail (Figure 5). Tighten the leaf spring pivot bolt to hold in place. Using a 1/2" drill bit, drill through the bottom side of the frame rail, using the (2) frame mount bracket mounting holes as a drill guide (Figure 6).

Figure 7: Bump Stop Mounting



Figure 8: Bump Stop Mounting Nut



4. Once the mounting hole locations are drilled, remove the bracket. Using the hardware listed below, mount the bump stop the frame mount bracket (Figure 7). Do not over-tighten the bump stop, only tighten the nut until the bump stop is firmly held in place (Figure 8).
 - a. (1) - Black Polyurethane Bump-Stop (Part #6079G)
 - b. (1) - Socket Head Cap Screw 3/8"-16 UNC X 1.00 Lg.
 - c. (1) - SAE 3/8" Flat Washer
 - d. (1) - 3/8"-16 UNC Lock Nut.

5. Re-install the frame mount bracket and assemble using the hardware listed below (Figure 9). Tighten both 1/2"-13 UNC bolts and leaf spring pivot bolt to 95 ft.-lbs. (Figure 10):
 - a. (2) - Cap Screw 1/2"-13 UNC x 1.25 Lg.
 - b. (2) - 1/2"-13 UNC Lock Nut
 - c. (4) - 1/2" SAE Flat Washer

Figure 9: Frame Mount Bracket Hardware



Figure 10: Front Mount Installed

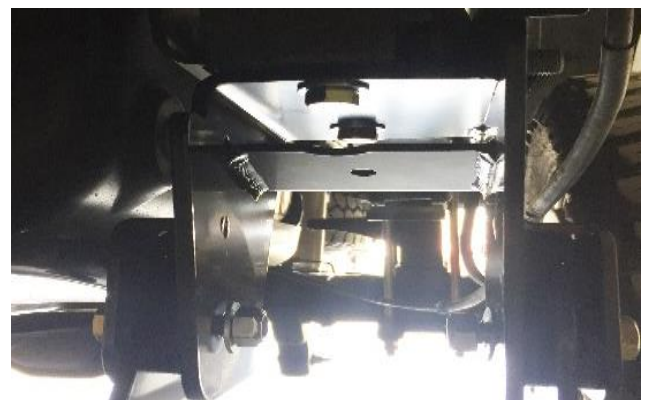

Figure 11: Traction Bar Shackle Parts



6. Locate the following parts (Figure 11).

- a. (2) - Traction Bar Shackle (Part # 8460)
- b. (4) - Traction Bar Shackle Bushing (Part # 2581.01-MOD)
- c. (2) – Traction Bar Shackle Crush Sleeve (Part # 5036)

Figure 12: Install Shackle Bushings



Figure 13: Grease Shackle Bushings



7. Install (2) shackle bushings per shackle from each side (Figure 12). A light lubricant, WD-40, may be used to install but do not grease the outside of the bushing. Once the bushings are installed in shackles, then grease the inside bore of each bushing (Figure 13).

Figure 14: Install Shackle Crush Sleeves



Figure 15: Shackle Assembly



8. Install the crush sleeve by using a press or rubber mallet (Figure 14). Once installed, the crush sleeve should be flush with the bushing faces on both sides of the shackle (Figure 15).

Figure 16: Assemble Shackles to Frame Mount



Figure 17: Frame Bracket Assembled



9. Install the assembled shackle by inserting the shackle bushings into the frame bracket pivot pocket (Figure 16). Using the hardware listed below, assemble the shackles to the frame bracket (Figure 17), but do not tighten bolts at this time.
 - a. (2) - Cap Screw 1/2"-13 UNC x 2.25 Lg.
 - b. (4) - 1/2" SAE Flat Washer
 - c. (2) - 1/2"-13 UNC Lock Nut
 - d. (2) - 6" Traction Bar Shackle (Assembled)

Figure 18: Remove U-Bolt Nuts



Figure 19: Install Axle Mount Bracket



10. For this step, the vehicle will need to be lowered down to the ground. Once vehicle is on the ground at normal operating position, remove U-bolt nuts from the driver side leaf spring bracket (Figure 18). Install the FSD Axle Mount Bracket (Part # 8520) by sliding over the U-Bolts with traction bar mounting eyelets offset toward the front of the vehicle as shown (Figure 19). Replace the U-bolt nuts and tighten to 170 ft.-lbs.

Figure 20: Traction Bar Bushing Parts



11. Locate the following parts (Figure 20).
- (2) - 45" Boxed sheet metal traction bar (Part # 8521)
 - (4) - Traction bar poly bushing (Part # 2509.1)
 - (2) - Traction bar crush sleeve (Part # 5045)

Figure 21: Traction Bar Bushings Installed



Figure 22: Traction Bar Bushings Greased

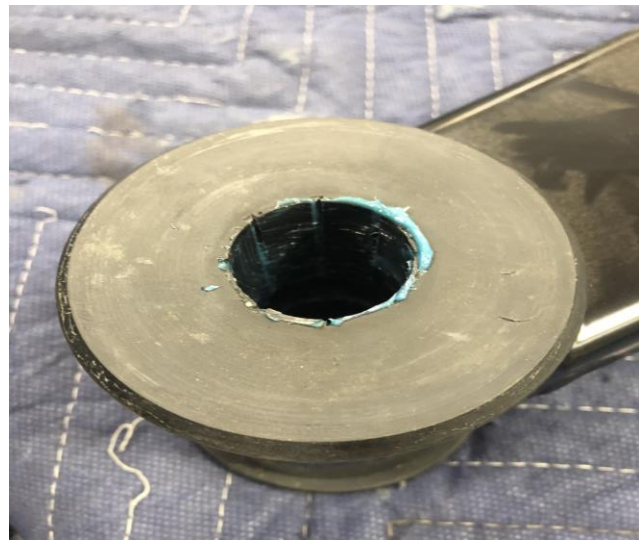

12. Install (2) traction bar bushings per traction bar from each side (Figure 21). A light lubricant, WD-40, may be used to install but do not grease the outside of the bushing. Once bushings are installed in traction bars, grease the inside bore of each bushing (Figure 22).

Figure 23: Install Crush Sleeve



Figure 24: Crush Sleeve Installed



13. Install the traction bar crush sleeve by using a press or rubber mallet (Figure 23). Once installed, the crush sleeve should be flush with the bushing faces on both sides of the traction bar (Figure 24).

Figure 25: Traction Bar / Shackle Pivot



14. Insert the traction bar end with bushings between the driver side shackles and install using the hardware listed below (Figure 25). Now tighten the shackle pivot bolts in the frame mount bracket assembly and traction bar pivot bolt to 135 ft.-lbs.

- a. (1) - Cap Screw 9/16"-12 UNC x 5.00 Lg.
- b. (2) - 9/16" SAE Flat Washer
- c. (2) - 9/16-12 UNC Lock Nut

Figure 26: Traction Bar Rod End



15. Prior to installing the traction bar rod end, make sure that the rod end and adjuster sleeve are threaded all the way into the traction bar tube (Figure 26).

Figure 27: Traction Bar Rod End / Rear Axle Pivot



Figure 28: Traction Bar Rod End / Rear Axle Pivot



16. Insert the traction bar rod end between the eyelets on the rear axle mount. Turning the adjuster sleeve only, lengthen the traction bar tube until the rod end lines up with holes in the traction bar mounting eyelets. Install using the hardware listed below and tighten to 135 ft.-lbs. (Figure 27 & 28).

- (1) - Cap Screw 9/16"-12 UNC x 4.00 Lg.
- (2) - 9/16" SAE Flat Washer
- (2) - 9/16"-12 UNC Lock Nut

Figure 29: Adjuster Nut Clamp



17. Once the traction bars have been installed, ensure that all hardware has been tightened to the specified torque specifications. Allow the vehicle to rest at ride height. Adjust the length of the traction bar by turning the adjustment sleeve. (Figure 28). Lengthen the bar until the adjuster gets tight or hard to turn freely, which happens when the traction bar is at its maximum length. Then shorten, (turn in opposite direction), by a 1/4 of revolution of the adjuster. With the traction bar length set, tighten the 3/8" socket head cap screws to 40 ft. /lbs. to lock the adjuster in place (Figure 29). **After completing these steps, the traction bar should form a very small angle with the shackle.** (Figure 31)

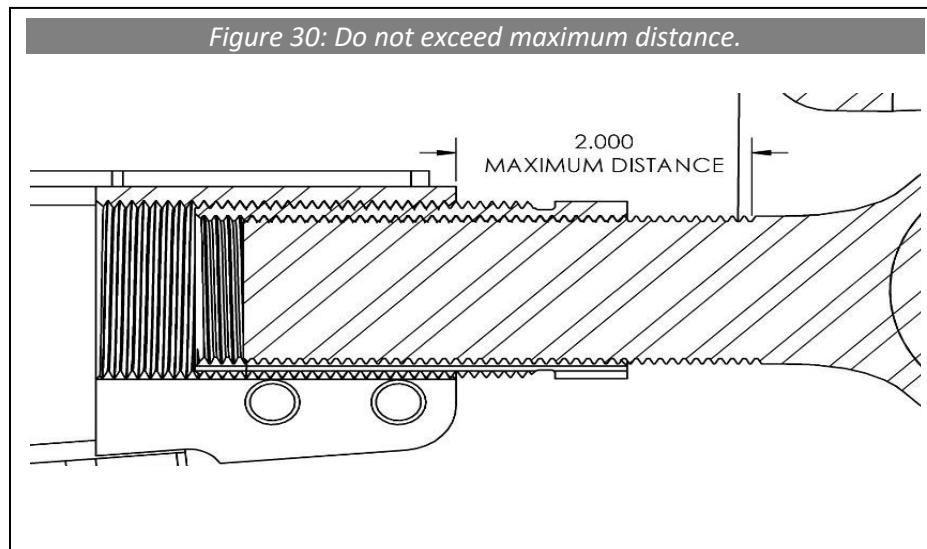
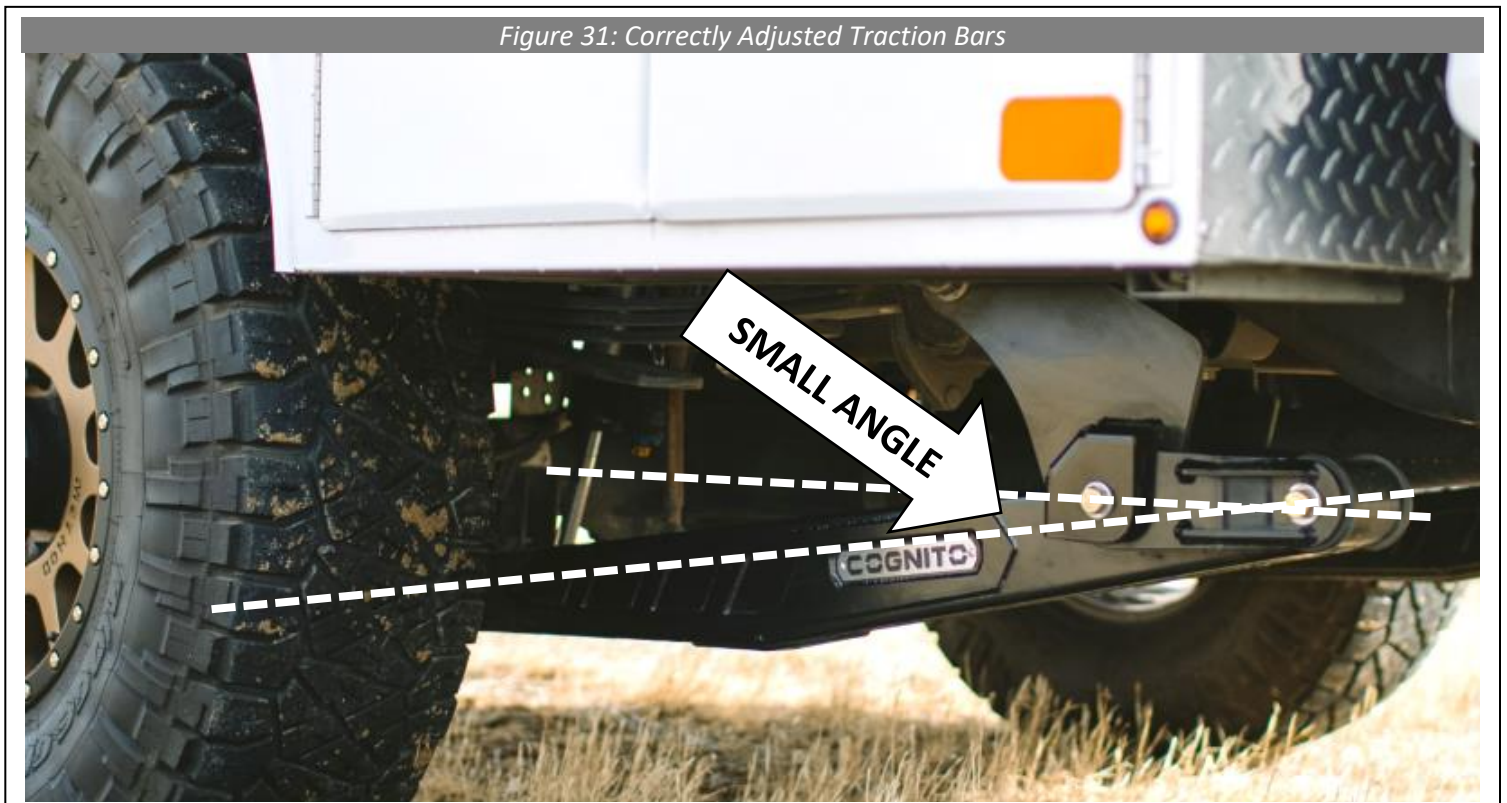

Figure 31: Correctly Adjusted Traction Bars



18. Re-Install the brake cable into mounting saddle, removed in step 2, and mounting bracket, removed in steps 1. Then torque to OE torque specifications.
19. Repeat these steps for the mounting and installation of the passenger side traction bar and mounts.