

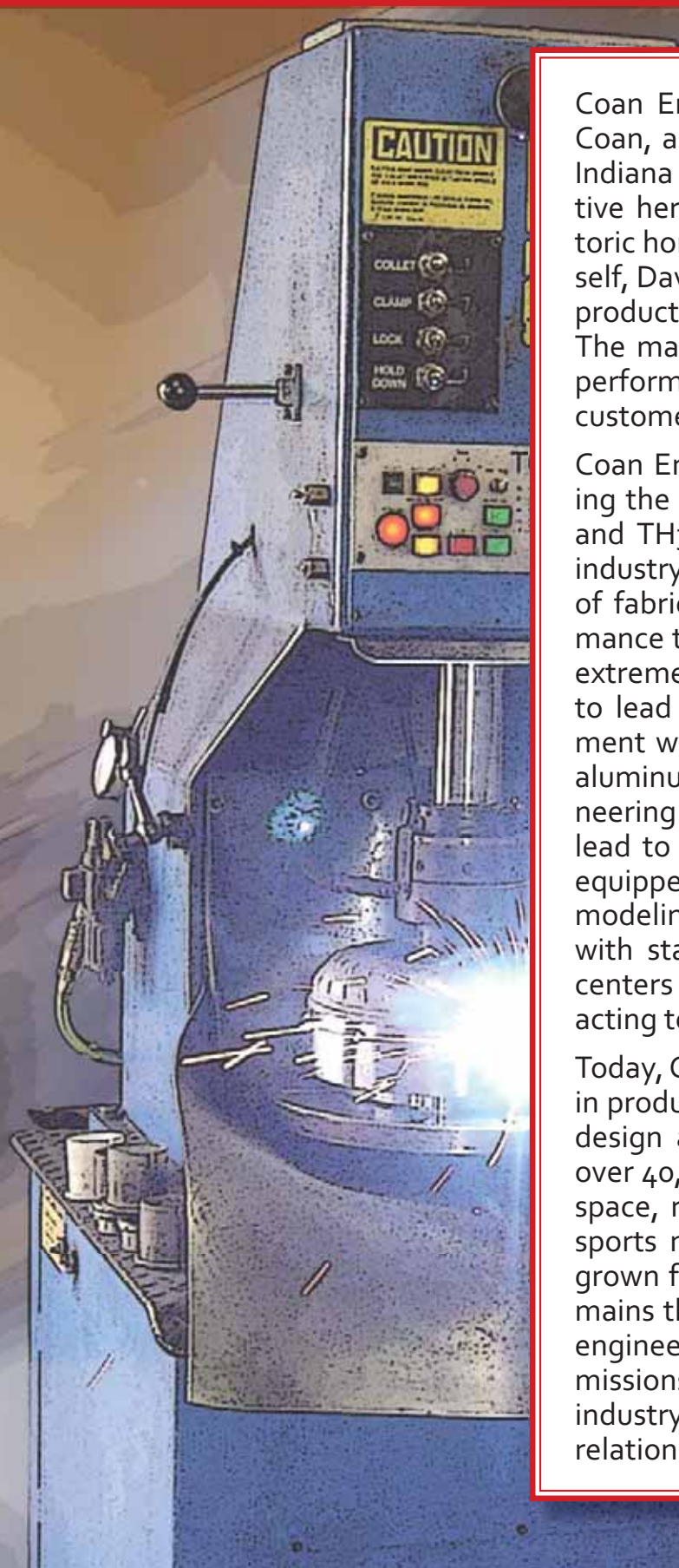

ST
O
O

About Coan Engineering



Coan Engineering was founded in 1976, by Dave Coan, as a two-man operation in a small Kokomo, Indiana garage. Kokomo is a town rich in automotive heritage, dating back to Elwood Haynes' historic horseless carriage ride of 1894. As a racer himself, Dave set out to offer a better and more refined product targeted initially at the drag racing market. The main goals of Coan Engineering in 1976 were performance, reliability, and commitment to its customers.

Coan Engineering played a major role in introducing the first transbrake for the Powerglide, TH400, and TH350 transmissions, now a standard in the industry. Coan Engineering also pioneered the use of fabricated steel stators in its maximum performance torque converters to withstand the rigors of extreme horsepower. Coan Engineering continues to lead the industry in torque converter development with a complete line of CNC machined billet aluminum stators. The commitment at Coan Engineering to be at the top of product development has led to a state-of-the-art engineering department equipped with the latest in CAD/CAM design and modeling software. Product manufacturing is done with state-of-the-art CNC turning and machining centers featuring full 5-axis capability to insure exacting tolerances.

Today, Coan Engineering is proud to be very diverse in product offering and remarkably self sufficient in design and manufacturing. The company boasts over 40,000 sq. ft of manufacturing and warehouse space, ready to serve customers from any motor-sports marketplace. While Coan Engineering has grown from its humble beginnings, the mission remains the same; "At Coan Engineering we strive to engineer the best performing, most reliable transmissions, torque converters, and components in the industry while maintaining unsurpassed customer relationships."

MIKRON 



UCP 60



XTRA-LITE Billet Aluminum Bolt-Together Converters

- CAD Designed, 5-Axis CNC Machined Billet Aluminum Pump
 - Billet Aluminum Front Cover
 - High Strength Nickel Furnace Brazed Turbine w/ Additional Tack Welding in High Stress Areas
 - Billet Steel Bolt-In Pump Hub
 - Heat Treated Turbine Splines
 - Lightweight yet Rigid Design will not Balloon and Cause Engine Damage
 - Multiple Pump and Stator Designs for Infinite Stall Speed Tuning
 - Bolt-Together Design
 - XST Sprag Available
 - Titanium Hardware Available
 - Available in 11", 10.5", 10", 9", 8", and 7"
 - **S** Spragless Available
 - **B** Billet Stator Available
- Custom Built Converter**



Powerglide		
Size	Part No	
7"	COA-10660X	
8"	COA-10560X	S

TH400 / TH350		
Size	Part No	
7"	COA-20660X	
8"	COA-20560X	S
9"	COA-20460-1X	B S
10"	COA-20360-2X	S
10.5"	COA-20260X	S
11"	COA-20260-4X	B S

XST / LENCO / BRUNO			
Size	Part No		
10"	COA-170360-2X	31 Spline	S
10"	COA-170360-2XA	29 Spline	S
10.5"	COA-170260X	31 Spline	S
10.5"	COA-170260XA	29 Spline	S
11"	COA-170260-4X	31 Spline	B S
11"	COA-170260-4XA	29 Spline	B S

Super Mega Bolt-Together Converters

- Billet Aluminum Front Cover
- High Strength Nickel Furnace Brazed Pump and Turbine w/ Additional Tack Welding in High Stress Areas
- Heat Treated and Ground Pump Drive Hub
- Heat Treated Turbine Splines
- Heavy Duty Roller Thrust Bearings
- Rigid Design will not Balloon and Cause Engine Damage
- Multiple Pump and Stator Designs for Infinite Stall Speed Tuning
- Bolt-Together Design
- XST Sprag Available
- Available in 11", 10.5", 10", 9", 8", and 7"

Ⓢ Spragless Available

ⓑ Billet Stator Available

Custom Built Converter



XST / Lenco / BRUNO			
Size	Part No		
9"	COA-170430X		Ⓢ
10"	COA-170330-2X	31 Spline	Ⓢ
10"	COA-170330-2XA	29 Spline	Ⓢ
10.5"	COA-170230X	31 Spline	Ⓢ
10.5"	COA-170230XA	29 Spline	Ⓢ
11"	COA-170230-4X	31 Spline	ⓑⓈ
11"	COA-170230-4XA	29 Spline	ⓑⓈ

Powerglide		
Size	Part No	
7"	COA-10600X	
7"	COA-10600XA	"Negative"

TH400 / TH350		
Size	Part No	
7"	COA-20600X	
7"	COA-20600XA	"Negative"
9"	COA-20430X	Ⓢ
10"	COA-20330-2X	Ⓢ
10.5"	COA-20230X	Ⓢ
11"	COA-20230-4X	ⓑⓈ

Maximum Performance Steel Stator Converters

- The Original Steel Stator Converter and Still the Best
 - Fabricated CNC Machined Steel Stators Provide Optimal Strength
 - Multiple Stator Designs Allow for Precise Converter Tuning
 - Coan Exclusive 9 or 11 Roller "Super Sprag"
 - High Strength Nickel Furnace Brazed Pump and Turbine w/ Additional Tack Welding in High Stress Areas
 - Heat Treated and Ground Pump Drive Hub
 - Heat Treated Turbine Splines
 - Heavy Duty Roller Thrust Bearings
 - Rigid Design will not Balloon and Cause Engine Damage
 - Available in 11", 10.5", 10", 9", 8", and 7"
- Ⓢ Spragless Available

Custom Built Converter



Powerglide		
Size	Part No	
7"	COA-10600	
7"	COA-10600A	"Negative"
8"	COA-10530	Ⓢ
9"	COA-10430	Ⓢ

TH400 / TH350		
Size	Part No	
7"	COA-20600	
7"	COA-20600A	"Negative"
8"	COA-20530	Ⓢ
9"	COA-20430	Ⓢ
10"	COA-20330	Ⓢ
10"	COA-20330-2	Ⓢ
11"	COA-20230	Ⓢ
11"	COA-20230-4	Ⓢ

TF727		
Size	Part No	
7"	COA-40600	
8"	COA-40530	Ⓢ
10"	COA-40330	Ⓢ

SPRAG VS SPRAGLESS

Here's the truth behind today's most debated performance converter topic. Believe it or not there's no right or wrong answer; they both work well when built properly for the application. The necessity of a sprag in a performance converter is determined by the type of vehicle and style of racing.

A spragless converter will never be faster than one with a sprag, but that doesn't mean a sprag is always the best choice.

Often times a car with a high horsepower-to-weight ratio can run both converters and see negligible difference in performance. For this reason spragless converters are often favored due to superb consistency and durability.

This is particularly the case in many Super Comp, Super Gas, and ET drag cars. Spragless converters generally produce more heat and for this reason are not good for street strip or off-road racing applications.

Contact Coan Engineering for your best sprag vs. spragless recommendation.



TF904	
Size	Part No
7"	COA-50600

C6	
Size	Part No
8"	COA-60530
9"	COA-60430
10"	COA-60330

C4	
Size	Part No
7"	COA-70600
8"	COA-70530
9"	COA-70430

XST / Lenco / BRUNO		
Size	Part No	
8"	COA-170530	
9"	COA-170430	
10"	COA-170330-2	31 Spline
10"	COA-170330-2A	29 Spline
10.5"	COA-170230	31 Spline
10.5"	COA-170230A	29 Spline
11"	COA-170230-4	31 Spline
11"	COA-170230-4A	29 Spline

SPECIALTY		
Size	Part No	
7"	COA-210600	4T65E
7"	COA-240600	Chry 404/604
8"	COA-160530	Quicker
8"	COA-160430	Quicker

Maximum Performance Converters

- Cast Aluminum Stator
- Special Stator Machining to Optimize Performance
- Coan Exclusive 9 or 10 Roller "Super Sprag"
- High Strength Nickel Furnace Brazed Pump and Turbine w/ Additional Tack Welding in High Stress Areas
- Heat Treated and Ground Pump Drive Hub
- Heat Treated Turbine Splines
- Heavy Duty Roller Thrust Bearings
- Billet Steel Front Cover Available on Certain Models
- Rigid Design will not Balloon and Cause Engine Damage
- Available in 10.5", 10", 9" and 8"
- **S** Spragless Available
- **B** Billet Stator Available

Custom Built Converter



Powerglide		
Size	Part No	
8"	COA-10510	BS
9"	COA-10450	BS
9"	COA-10450-1	BS
10"	COA-10320	S

TH400 / TH350		
Size	Part No	
8"	COA-20510	BS
9"	COA-20450	BS
9"	COA-20450-1	Billet Cover B
10"	COA-20320-2	S
10"	COA-20320-2A	Billet Cover S
10.5"	COA-20320-3	S
10.5"	COA-20320-3A	Billet Cover S

TF727		
Size	Part No	
8"	COA-40510	BS
9"	COA-40450-1	BS
10"	COA-40320	S
10.5"	COA-40320-3	Billet Cover S

WHY CHOOSE A BILLET STATOR?

While many torque converter companies continue to build racing converters with OEM or aftermarket replica cast aluminum stators, Coan Engineering is at the forefront of billet stator development. Coan billet stators are 5-axis CNC machined from solid 6061-T651 aluminum providing a 36% increase in ultimate tensile strength and 66% increase in yield strength over conventional A356-T6 cast aluminum stators.

The CNC machining process guarantees that each blade of each stator is EXACT, there are no inaccuracies or porosity as found with castings. The most important benefit of billet stators is the performance possibilities. Due to the expense associated with patterns and/or dies required to cast stators, most companies offer 1 or 2 stators that they modify to suit several applications. Coan Engineering starts with 3-D modeling software and designs purpose built racing stators specific to their intended application.

Not all billet stators are created equal! Don't settle for an imposter. Only Coan Billet stators are completely machined from a single piece of material. Most other billet stators feature an outer band that is welded or pinned to the stator blades which drastically reduces strength. Billet stators from Coan Engineering are proof of our commitment to performance drivetrain development.



11" Billet Aluminum Stator

9" Billet Aluminum Stator

8" Billet Aluminum Stator

7" Billet Aluminum Stator



COA-20450-1



COA-20320-2

TF904		
Size	Part No	
8"	COA-50510	BS

C6		
Size	Part No	
8"	COA-60510	BS
9"	COA-60450	BS
10"	COA-60320	S
10"	COA-60320-2A	S

C4		
Size	Part No	
8"	COA-70510	BS
9"	COA-70450	BS
10"	COA-70320	S

4L80E		
Size	Part No	
9"	COA-100450-1	B
10.5"	COA-100310-3A	

SPECIALTY		
Size	Part No	
9"	COA-270420-1	Fortin
9"	COA-310420-1	Albins

High Performance Converters

- Stall Speeds up to 6500 RPM
Varies by Size and Model
- Cast Aluminum Stator
- Heavy Duty Sprag
- High Strength Nickel Furnace Brazed Pump and Turbine w/
Additional Tack Welding in High Stress Areas
- Heat Treated and Ground Pump Drive Hub
- Heat Treated Turbine Splines
- Heavy Duty Roller Thrust Bearings
- Rigid Design will not Balloon and Cause Engine Damage
- Transbrake Compatible
- Available in 10", 9" and 8"
-  Spragless Available



Tech Talk

WHAT IS STALL SPEED?

Torque converter stall speed is an often misunderstood topic. The definition of stall speed is "the highest rpm the engine can reach at full throttle under a full load condition." Basically, if the drivetrain were locked and the engine was given full throttle, the rpm would "stall" at this point.

Although vehicles with transbrakes can simulate this, it is not recommended to check stall speed in that manner. The safest and most accurate way for racers to determine stall rpm is to record the rpm that the engine falls back to after a shift.

Many times "brake torque rpm" is confused with stall speed. Unfortunately very few vehicles have enough brake capacity to lock the drivetrain well enough for the engine to reach true stall speed. That's why brake torque stall is always lower than actual stall speed.



Powerglide	
Size	Part No
8"	COA-10500 
8"	COA-10501 thru COA-20507
8"	COA-10520
9"	COA-10400-1

TH400 / TH350	
Size	Part No
8"	COA-20500 
8"	COA-20501 thru COA-20507
8"	COA-20520
9"	COA-20400-1
9"	COA-20425-1 Big Block
9"	COA-20428-1 Small Block
10"	COA-20325-1

Competition Converters

- Race Inspired Features an Economical Street/Strip Package
- Stall Speeds up to 4000 RPM
Varies by Size and Model
- Cast Aluminum Stator
- Heavy Duty Sprag
- High Strength Nickel Furnace Brazed Pump and Turbine
- Heat Treated and Ground Pump Drive Hub
- Heat Treated Turbine Splines
- Heavy Duty Roller Thrust Bearings
- Not Recommended for use with Transbrake
- Available in 10" and 9"
- Circle Track Specific Models Available

Custom Built Converter



Powerglide		
Size	Part No	
9"	COA-10408-1	Circle Track

TH400 / TH350		
Size	Part No	
9"	COA-20416-1	Big Block
9"	COA-20417-1	Small Block
9"	COA-20408-1	Circle Track

TF727		
Size	Part No	
10"	COA-40312	Big Block
10"	COA-40313	Small Block

TF904		
Size	Part No	
10"	COA-50310	

C6 (Specify 1.848 or 1.375 Pilot)		
Size	Part No	
10"	COA-60311	Big Block
10"	COA-60312	Small Block

C4 (Specify 24/26 Spline and Bolt Circle)		
Size	Part No	
10"	COA-70311	
10"	COA-70312	

SPECIALTY		
Size	Part No	
10"	COA-2030310	Boss Hoss

Pro Street Converters

- Race Inspired Features in an Economical Street Performance Package
- Stall speeds up to 3500 RPM
Varies by Size and Model
- Cast Aluminum Stator
- Heavy Duty Sprag
- High Strength Nickel Furnace Brazed Pump and Turbine
- Heat Treated and Ground Pump Drive Hub
- Heat Treated Turbine Splines
- Heavy Duty Roller Thrust Bearings on Major Thrust Surfaces
- Not Recommended for use with Transbrake
- Available in 13", 12", 11", and 10"

Custom Built Converter



TH400 / TH350		
Size	Part No	
11"	COA-20211-4	Big Block
11"	COA-20212-4	Big/Small Block
11"	COA-20213-4	Small Block

TF727		
Size	Part No	
11"	COA-40210	
11"	COA-40215	
11"	COA-40215A	Lock-Up

TF904		
Size	Part No	
11"	COA-50215	
11"	COA-50215A	Lock-Up
11"	COA-50215B	Lock-Up

700R4 / 4L60E		
Size	Part No	
12"	COA-90111-0	27 Spline
12"	COA-90111-1	30 Spline
10"	COA-90315-0	27 Spline
10"	COA-90315-1	30 Spline

4L80E		
Size	Part No	
13"	COA-100010	Lock-Up

Maximum Performance Lock-Up Converters



Billet Steel
Triple Disk
Lock-Up Cover



Billet Steel
Apply Plate

Triple Disk
Lock-Up Clutches

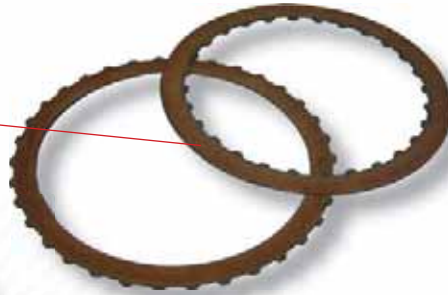

COA-110310

COA-350310-3-3



- Billet Steel Front Cover for Ultimate Clutch Face Rigidity
- Billet Steel Apply Plate for Ultimate Clutch Face Rigidity
- Single or Triple Disk Lock-Up Available
- Premium Power Torque Friction Material
- Cast Aluminum Stator
- Heavy Duty Sprag
- Coan Exclusive 10 Roller "Super Sprag" Available
Required for Transbrake Applications
- High Strength Nickel Furnace Brazed Pump and Turbine w/ Additional Tack Welding in High Stress Areas
- Heat Treated and Ground Pump Drive Hub
- Heat Treated Turbine Splines
- Heavy Duty Roller Thrust Bearings
- Available in 13", 10.5", and 10"

Custom Built Converter

700R4		
Size	Part No	
10"	COA-90310	Single Disk
10.5"	COA-90310-3-3	Triple Disk

4L80E		
Size	Part No	
10.5"	COA-100310-3	Single Disk
10.5"	COA-100310-3-3	Triple Disk
13"	COA-100010A	Single Disk

4L60E		
Size	Part No	
10"	COA-110310	Single Disk
10.5"	COA-110310-3	Single Disk
10.5"	COA-110310-3-3	Triple Disk

6L80E		
Size	Part No	
10.5"	COA-350310-3	Single Disk
10.5"	COA-350310-3-3	Triple Disk

A618 / 48RE		
Size	Part No	
13"	COA-180004A	Single Disk
13"	COA-180004A-3	Triple Disk

Superglide XST

- 1-1/4" 29 Spline Input Shaft
- 1-3/8" TH400 Output Shaft
- 32 Spline Billet Bolt-In Pump Stator
- Billet Ductile Iron Gerotor Pump
- Billet Aluminum Pump Available
- 12 DP Straight Cut Planetary Gears
1.80 Ratio
- Billet Aluminum Planetary Carrier
- Modular Billet Aluminum
"Super Drum"
- 10 Clutch High Gear
- 2-1/4" Wide Low Band
- "Super Servo"
- Pro-Brake w/ Adjustable Pressure
Regulator
- Fabricated Deep Pan
- "Super Filter"
- P-R-N-2-1 Shift Pattern

Superglide XST

Xtreme Strength Technology

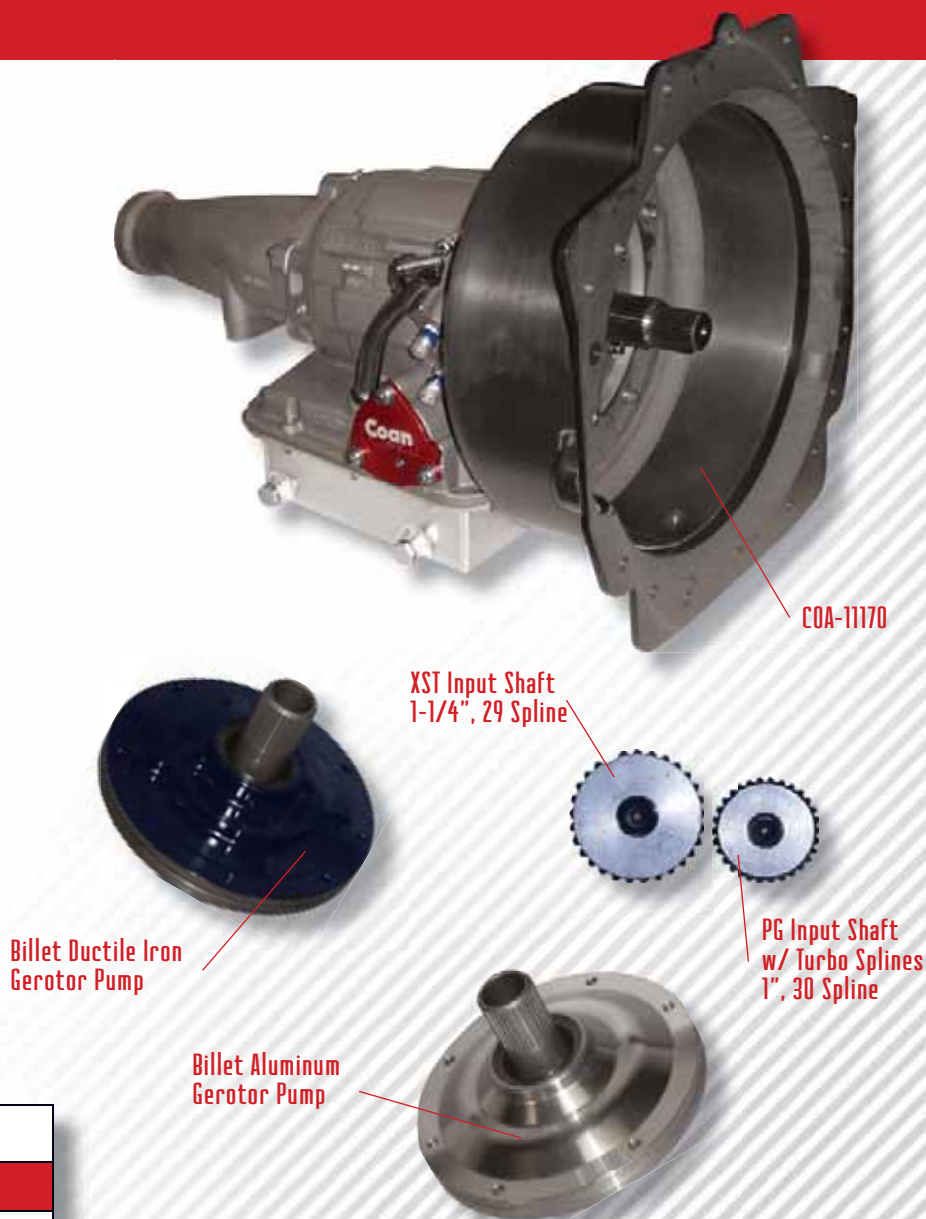

Superglide XST Components

Part No

COA-12870	XST Kit
-----------	---------

Superglide XST

Part No

Description

COA-11170

SUPERGLIDE XST W/ TRANSBRAKE, 1-1/4" SUPER ALLOY INPUT SHAFT, 1-3/8" (TH400) ALLOY OUTPUT SHAFT, HIGH VOLUME GEROTOR PUMP, STEEL ALLOY BOLT-IN PUMP STATOR, 2000+ LB/FT CLUTCH PACK, 1.80 RATIO, REQUIRES XST/LENCO/BRUNO TORQUE CONVERTER AND DO2-PGYMW-400R YOKE

COA-11180

SUPERGLIDE XST W/ TRANSBRAKE, 18" SHORTY LENGTH, 1-1/4" SUPER ALLOY INPUT SHAFT, 1.375" (TH400) ALLOY OUTPUT SHAFT, HIGH VOLUME GEROTOR PUMP, STEEL ALLOY BOLT-IN PUMP STATOR, 2000+ LB/FT CLUTCH PACK, 1.80 RATIO, REQUIRES XST/LENCO/BRUNO TORQUE CONVERTER

COA-11185

MONSTERGLIDE XST, 18" SHORTY LENGTH, HIGH PRESSURE REVERSE BOOST MANUAL (DESIGNED SPECIFICALLY FOR MONSTER TRUCK RACING), 1-1/4" SUPER ALLOY INPUT SHAFT, 1-3/8" (TH400) ALLOY OUTPUT SHAFT, HIGH VOLUME GEROTOR PUMP, STEEL ALLOY BOLT-IN PUMP STATOR, 2000+ LB/FT CLUTCH PACK, 1.80 RATIO, REQUIRES XST/LENCO/BRUNO TORQUE CONVERTER

Turbo II XST

Xtreme Strength Technology

Turbo II (2-Speed)

- Powerglide Alternative w/ Multiple Ratios
- 30 Spline TH400 Input Shaft
300M Alloy or "Super Shaft"
- Alloy Main Shaft
300M Alloy or "Super Shaft"
- 36 Element Low Sprag
- Billet Alloy Forward Clutch Hub
- Billet Aluminum Low Gear Hub
- Aluminum Deep Pan
- Pro-Brake
- P-R-N-2-1 Shift Pattern
- Available Ratios:
1.31, 1.35, 1.40, 1.44, 1.48, 1.56

OPTIONAL COMPONENTS

- Billet Aluminum Direct Drum
- Billet Aluminum Forward Drum
- Billet Aluminum Center Support
- Reid SFI Case



Turbo II XST

Includes all Turbo II Features Plus

- 1-1/4" 29 Spline Input Shaft
- Billet 32 Spline Bolt-In Stator Shaft
- Ultimate Super Alloy Main Shaft
- Billet Forward Drum
Aluminum or Steel
- Billet Aluminum Direct Drum
- SFI Certified Bellhousing

OPTIONAL COMPONENTS

- Billet Aluminum Center Support
- Reid SFI Case

Turbo II XST Components

Part No	
COA-22030	Valvebody Kit
COA-22883	Low Clutch Eliminator
COA-22898B	Billet Center Support
COA-22880	XST Kit

Turbo II / Turbo II XST

Part No	Description
COA-21220	TURBO II W/ PRO-BRAKE, 300M ALLOY INPUT SHAFT, 300M ALLOY MAIN SHAFT, STEEL CLUTCH HUB, SUPER SPRAG, CAST FORWARD AND DIRECT DRUMS, DEEP ALUMINUM PAN, STRAIGHT CUT LOW GEAR PLANETARY, P-R-N-2-1 FORWARD SHIFT PATTERN, CHEVROLET 4" EXT.
COA-21230	TURBO II W/ PRO-BRAKE, 6.7" OD HIGH TORQUE ALUMINUM CLUTCH DRUMS, SUPER ALLOY INPUT SHAFT, SUPER ALLOY MAIN SHAFT, STEEL CLUTCH HUB, SUPER SPRAG, BILLET ALUMINUM FORWARD AND DIRECT DRUMS, DEEP ALUMINUM PAN, STRAIGHT CUT LOW GEAR PLANETARY, P-R-N-2-1 FORWARD SHIFT PATTERN, CHEVROLET 4" EXT.
COA-21240	TURBO II W/ PRO-BRAKE, 5.8" OD HIGH TORQUE ALUMINUM CLUTCH DRUMS, SUPER ALLOY INPUT SHAFT, SUPER ALLOY MAIN SHAFT, STEEL CLUTCH HUB, SUPER SPRAG, DEEP ALUMINUM PAN, STRAIGHT CUT LOW GEAR PLANETARY, LIGHTWEIGHT HELICAL REVERSE, P-R-N-2-1 FORWARD SHIFT PATTERN, CHEVROLET 4" EXT.
COA-21250	TURBO II XST W/ PRO-BRAKE, 1-1/4" 29 SPLINE INPUT SHAFT, HIGH TORQUE 6.7" ALUMINUM CLUTCH DRUMS, MAXIMUM DUTY STRAIGHT CUT PLANETARIES, ULTIMATE SUPER ALLOY MAIN SHAFT, BALL BEARING DRUM SUPPORT, FABRICATED PRO-STOCK PAN, P-R-N-2-1 FORWARD SHIFT PATTERN, ROLLER BEARING TAILHOUSING, SFI CHEVY BELLHOUSING

400-XLT

- Xtra-Lite Technology
- 6.7" Rotating Assembly
"Big Dog" XLT Feature
- 5.8" Rotating Assembly
"Ultimate" XLT Feature
- 30 Spline TH400 Input Shaft
300M Alloy or "Super Shaft"
- Alloy Main Shaft
300M Alloy or "Super Shaft"
- Billet Aluminum Forward Drum
- Billet Aluminum Direct Drum
34 Element or "Super Sprag"
- Ball Bearing Direct Drum Support
- Standard, Pro, or Clean Neutral
Transbrake
- Fabricated Deep Pan
- Available Ratios:
1.86-1.31, 1.95-1.34, 2.00-1.36, 2.10-1.40,
2.21-1.44, 2.33-1.48, 2.48-1.48, 2.56-1.56,
2.75-1.56, 2.98-1.56

400-XLT Xtra-Lite Technology

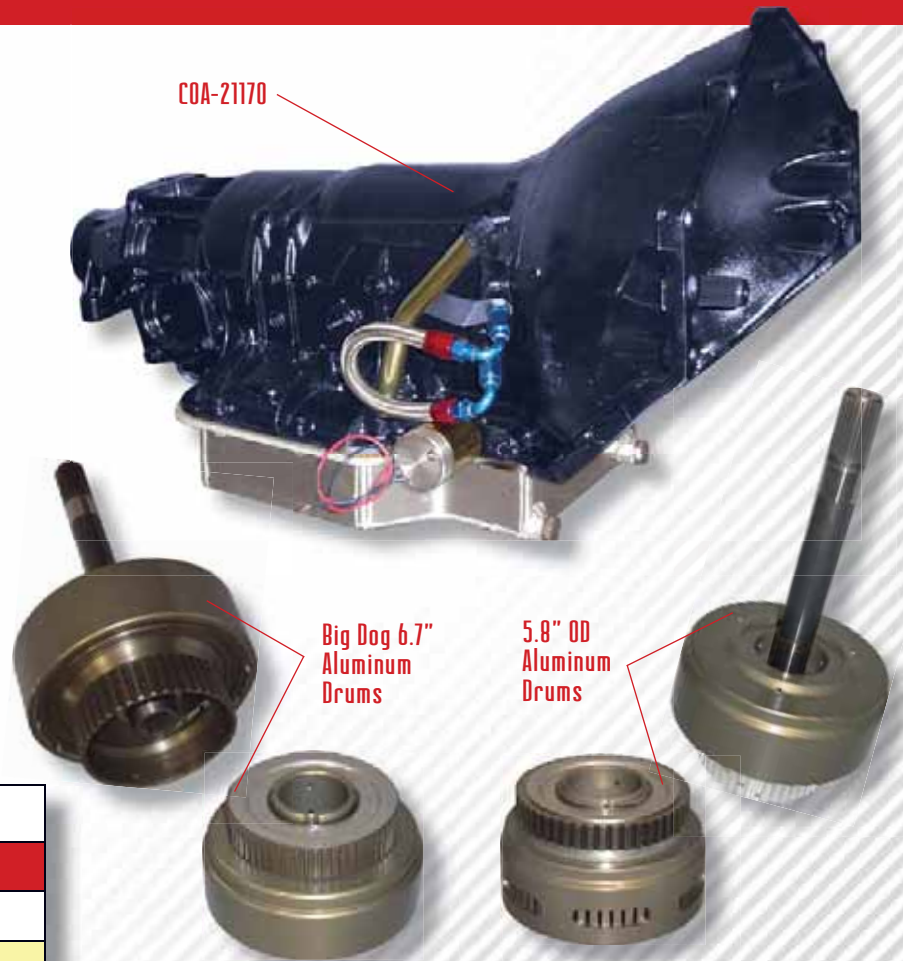

400-XLT Components

Part No

COA-22870 "Class" XLT Kit

COA-22871 "Max Perf" XLT Kit

400-XLT

Part No

Description

COA-21140 ULTIMATE CLASS COMPETITION 400-XLT MANUAL, XTRA-LITE 5.8" OD ALUMINUM DRUMS, XTRA-LITE ALUMINUM PLANETARY CARRIERS, HEAVY DUTY 34 ELEMENT SPRAG, 300M ALLOY INPUT SHAFT, PRECISION BALL BEARING DRUM SUPPORT, FABRICATED DEEP ALUMINUM PAN, SPUR-CUT PLANETARY (CHOICE OF RATIO: 2.10-1.40, 2.21-1.44, 2.33-1.48, 2.98-1.56), REVERSED PATTERN

COA-21150 ULTIMATE CLASS COMPETITION 400-XLT W/ TRANSBRAKE, XTRA-LITE 5.8" OD ALUMINUM DRUMS, XTRA-LITE ALUMINUM PLANETARY CARRIERS, HEAVY DUTY 34 ELEMENT SPRAG, 300M ALLOY INPUT SHAFT, PRECISION BALL BEARING DRUM SUPPORT, FABRICATED DEEP ALUMINUM PAN, SPUR-CUT PLANETARY (CHOICE OF RATIO: 2.10-1.40, 2.21-1.44, 2.33-1.48, 2.98-1.56), STD OR PRO BRAKE, REVERSED PATTERN

COA-21160 ULTIMATE PERFORMANCE 400-XLT W/ TRANSBRAKE, XTRA-LITE 5.8" OD ALUMINUM DRUMS, XTRA-LITE MAXIMUM DUTY ALUMINUM PLANETARY CARRIERS, SUPER SPRAG 36 ELEMENT SPRAG, SUPER ALLOY INPUT SHAFT, 300M ALLOY MAIN SHAFT, PRECISION BALL BEARING DRUM SUPPORT, FABRICATED DEEP ALUMINUM PAN, SPUR-CUT PLANETARY (CHOICE OF RATIO: 2.10-1.40, 2.21-1.44, 2.33-1.48, 2.98-1.56), STD OR PRO CLEAN "N" BRAKE, REVERSED PATTERN

COA-21170 BIG DOG 400-XLT W/ TRANSBRAKE, XTRA-LITE HIGH TORQUE 6.7" OD ALUMINUM DRUMS, XTRA-LITE MAXIMUM DUTY ALUMINUM PLANETARY CARRIERS, SUPER SPRAG 36 ELEMENT SPRAG, SUPER ALLOY INPUT SHAFT, 300M ALLOY MAIN SHAFT, PRECISION BALL BEARING DRUM SUPPORT, FABRICATED DEEP ALUMINUM PAN, SPUR-CUT PLANETARY (CHOICE OF RATIO: 2.10-1.40, 2.21-1.44, 2.33-1.48, 2.98-1.56), STD OR PRO CLEAN "N" BRAKE, REVERSED PATTERN

350-XLT

Xtra-Lite Technology

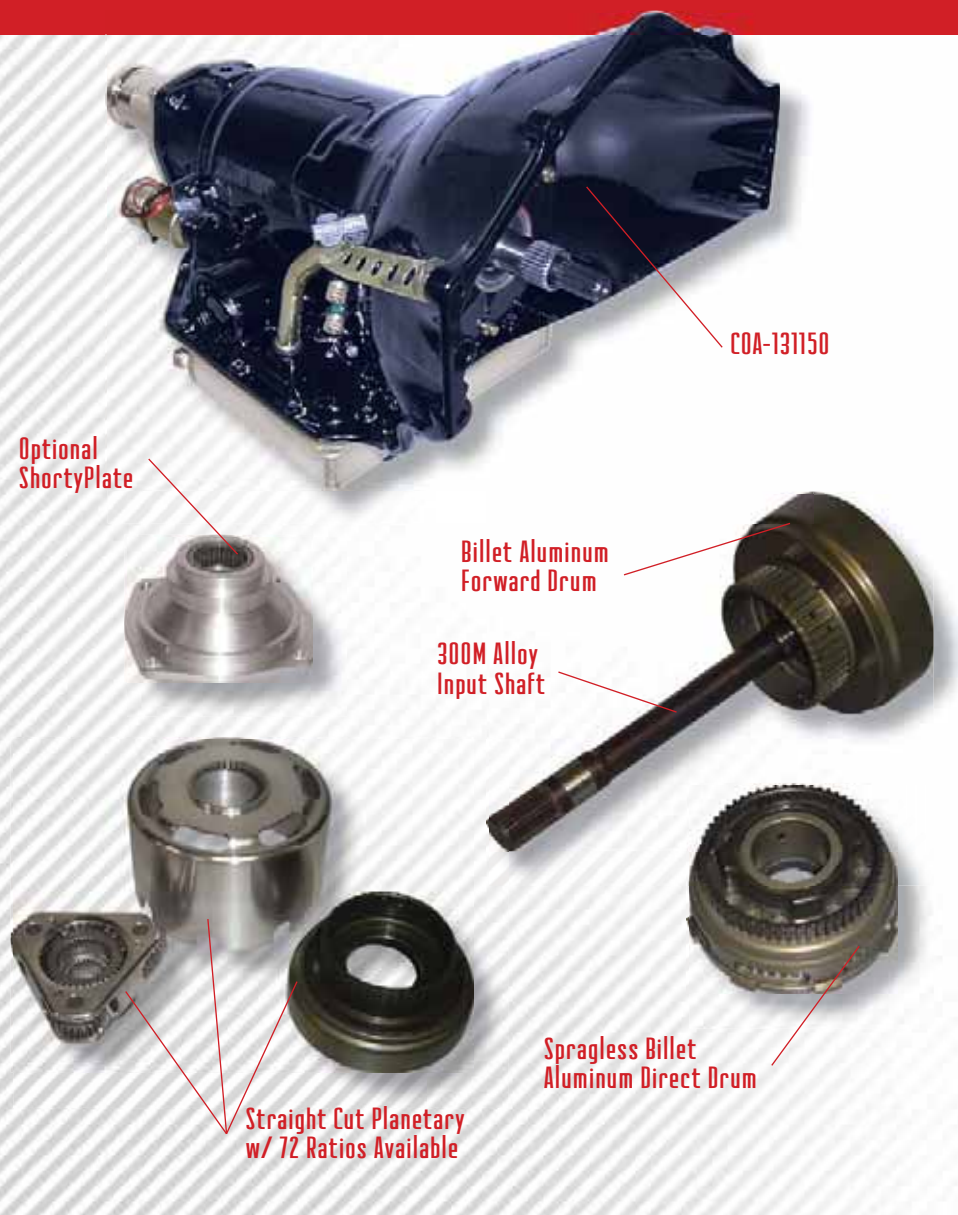

350-XLT

- Xtra-Lite Technology
- 5.8" Rotating Assembly
- Spragless Valve Body
"Ultimate Class" XLT Feature
- 300M Alloy Input Shaft
PG or TH Spline
- Billet Aluminum Forward Drum
- Billet Aluminum Direct Drum
- Ball Bearing Direct Drum Support
- Billet Aluminum Sun Shell
- Billet Aluminum Planetary Carriers
- Billet Aluminum Roller Bearing Extension Housing
"Ultimate Class" XLT Feature
- Straight Cut Planetary Gears
- 72 Gear Ratios Available
See Complete List at CoanRacing.com

OPTIONAL COMPONENTS

- 21" Shorty Length

350-XLT

Part No	Description
COA-131112	350-XLT CLASS COMPETITION MANUAL W/ CERAMIC BALL BEARING DRUM SUPPORT, 2.70-1.52 RATIO (HELICAL), STD. PATTERN
COA-131120	350-XLT CLASS COMPETITION MANUAL W/ TRANSBRAKE, CERAMIC BALL BEARING DRUM SUPPORT, 300M ALLOY INPUT SHAFT, CHOICE OF RATIO: 1.90-1.31, 2.00-1.34, 2.10-1.37, 2.20-1.41, REVERSED PATTERN
COA-131140	ULTIMATE TOP STOCK 350-XLT MANUAL W/ CLEAN NEUTRAL, STRAIGHT CUT GEARS (CHOICE OF 72 RATIOS), BILLET ALUMINUM ROTATING ASSEMBLY, CERAMIC BALL BEARING DRUM SUPPORT, FABRICATED DEEP PAN, BILLET ROLLER BEARING EXTENSION HOUSING, P-R-1-2-3-N SHIFT PATTERN (REQUIRES P08-408 OR P08-458 SHIFTER)
COA-131150	ULTIMATE CLASS COMPETITION 350-XLT W/ TRANSBRAKE AND CLEAN NEUTRAL, STRAIGHT CUT GEARS (CHOICE OF 72 RATIOS), BILLET ALUMINUM ROTATING ASSEMBLY, LOW VOLUME PUMP W/ CERAMIC BALL BEARING DRUM SUPPORT, 300M ALLOY INPUT SHAFT, FABRICATED DEEP PAN, BILLET ROLLER BEARING EXTENSION HOUSING, P-R/N-1-2-3-N SHIFT PATTERN (REQUIRES P08-408 OR P08-458 SHIFTER)

Powerglide Transmissions

- Most Popular Drag Racing Transmission
- "Bracket" or "Pro Tree" Transbrake
- Billet Alloy Clutch Hub
- 1.76 or 1.82 Standard Ratio

OPTIONAL COMPONENTS

- 18" Shorty Length
- 300M Alloy, "Super Shaft" or Ringless "Super Shaft" Input Shaft
- Straight Cut Planetary Gears, 1.80 or 1.69 Ratio
- Aluminum Planetary Carrier
- Alloy Output Shaft
- 10 Clutch "Super Drum"
- Reid SFI Case
- Billet Gerotor Pump
Aluminum or Ductile Iron
- Deep Aluminum Pan
Cast or Fabricated



Powerglide Transmissions

Part No	18" Shorty	Description
COA-11120	COA-11140	COMPETITION MANUAL W/ TRANSBRAKE, STEEL HUB, 6 CLUTCH, 300M ALLOY SHAFT (TH SPLINE), DEEP ALUMINUM PAN
COA-11123	COA-11143	PRO TREE COMPETITION, INSTANT REACTION PRO TREE 5 BRAKE W/REVERSE LOCK OUT, STEEL HUB, 6 CLUTCH, 300M ALLOY SHAFT (TH SPLINE), DEEP ALUMINUM PAN
COA-11124	COA-11147	ULTIMATE BIG DOG SUPER GLIDE W/ TRANSBRAKE, REVERSE LOCKOUT, STEEL HUB, RINGLESS AEROSPACE ALLOY SUPER SHAFT, BILLET SUPER PUMP W/ BOLT-IN STATOR, MAXIMUM DUTY STRAIGHT CUT PLANETARY W/ ALUMINUM CARRIER, BILLET OUTPUT SHAFT, SUPER DRUM 10 CLUTCH (BLUE) , FABRICATED DEEP ALUMINUM PAN, REID CASE & TAILHOUSING
COA-11126	COA-11146	EXTREME PERFORMANCE W/ INSTANT REACTION PRO TREE 5 BRAKE, STEEL HUB, SUPER SHAFT, MAXIMUM DUTY PLANETARY W/ ALUMINUM CARRIER, BILLET OUTPUT SHAFT, SUPER DRUM 9 CLUTCH, CAST DEEP ALUMINUM PAN
COA-11128	COA-11148	INSTANT REACTION W/ PRO TREE 5 BRAKE, STEEL HUB, 300M ALLOY SHAFT (TH SPLINE), EXTREME DUTY PLANETARY, 8 CLUTCHES, BILLET SERVO, DEEP ALUMINUM PAN

Powerglide Components

COA-12804A



Ringless PG Shaft
COA-12805



COA-12828C

COA-12040



COA-12823

Powerglide Components

Part No	Description
COA-12020	TRANSBRAKE KIT (STD. PATTERN)
COA-12023	PRO TREE 5 BRAKE KIT, INSTANT REACTION W/ REVERSE LOCKOUT SAFETY FEATURE, ADJUSTABLE PRESSURE REGULATOR (STD. PATTERN)
COA-12040	TRANSBRAKE REPLACEMENT SOLENOID
COA-12107	MASTER OVERHAUL KIT, INCLUDES 5 DIRECT, 5 REV CLUTCHES, STEELS, GASKETS & RINGS, NO BAND OR FILTER
COA-12721	MAXIMUM DUTY PLANETARY STD. LENGTH, ALUMINUM CARRIER, BILLET BOLT-ON OUTPUT SHAFT, STRAIGHT CUT GEARS, 1.80 RATIO
COA-12721A	EXTREME DUTY PLANETARY STD. LENGTH, STEEL CARRIER, BILLET BOLT-ON OUTPUT SHAFT, STRAIGHT CUT GEARS, 1.80 RATIO
COA-12802	300M ALLOY SHAFT, TURBO SPLINES, 12-7/8" (FITS 1.69, 1.76, 1.80, 1.89, 1.96, 2.03)
COA-12804A	SUPER SHAFT AEROSPACE ALLOY INPUT SHAFT, TURBO SPLINES, (SHOT PEENED) 12-7/8" (FITS 1.69, 1.76, 1.80, 1.89, 1.96, 2.03)
COA-12805	RINGLESS SUPER SHAFT AEROSPACE ALLOY INPUT SHAFT, TURBO SPLINES, (SHOT PEENED) 12-7/8", REQUIRES COA-12814, COA-12815, COA-12816A, OR COA-12816B PUMP (FITS 1.69, 1.76, 1.80, 1.89, 1.96, 2.03)
COA-12806	300M ALLOY RINGLESS ALLOY INPUT SHAFT, TURBO SPLINES, 12-7/8", REQUIRES COA-12814, COA-12815, COA-12816A, OR COA-12816B PUMP (FITS 1.69, 1.76, 1.80, 1.89, 1.96, 2.03)
COA-12811	PUMP ASSEMBLY, RACE PREPARED W/ HEAT TREATED STATOR SUPPORT & BUSHING FOR TURBO SHAFT
COA-12814	EXTREME RACE PUMP ASSEMBLY FOR RINGLESS SUPER SHAFT (FOR DIRECT DRUM W/ BUSHING)
COA-12816	SUPER PUMP GEROTOR PUMP ASSEMBLY W/ BOLT-IN ALLOY STATOR SUPPORT, USE W/ RING TYPE INPUT SHAFT (REQUIRES BEARING COA-12421)
COA-12816AL	SUPER PUMP BILLET ALUMINUM GEROTOR PUMP ASSEMBLY W/ BOLT-IN ALLOY STATOR SUPPORT, USE W/ RING TYPE INPUT SHAFT AND BUSHING TYPE DRUM (REQUIRES BEARING COA-12421)
COA-12823	EXTREME DUTY STEEL DIRECT CLUTCH HUB (8 CLUTCH)
COA-12828C	SUPER DRUM KIT (10 CLUTCH), INCLUDES BILLET ALUMINUM SUPPORT W/ BUSHING, MAXIMUM DUTY SUPER ALLOY HUB, BILLET STEEL REACTION FLANGE (12DP STRAIGHT CUT) (REQUIRES CLUTCH KIT COA-12208-A)
COA-12831	CAST ALUMINUM DEEP PAN KIT
COA-12846A	BILLET SERVO PISTON, INCLUDES DUAL CAST METAL RINGS
COA-12849	ALUMINUM REAR SUPPORT W/ BEARING

TH400 Transmissions

- Most Durable General Motors Transmission
- Automatic, Manual Shift, and Transbrake Valvebodies Available
- 2.48-1.48 Standard Ratio

OPTIONAL COMPONENTS

- Chevrolet or Buick/Olds/Pontiac Case
- 34 Element or "Super Sprag" Intermediate Sprag
- Billet Alloy Forward Clutch Hub
- 300M Alloy or "Super Shaft" Input Shaft
- 300M Alloy, "Super Shaft", or "Ultimate" Main Shaft
- Billet Forward Drum
Aluminum or Steel
- Billet Direct Drum
Aluminum or Steel
- Available Ratios:
1.86-1.31, 1.95-1.34, 2.00-1.36, 2.10-1.40,
2.21-1.44, 2.33-1.48, 2.56-1.56, 2.75-1.56,
2.98-1.56



TH400 Transmissions

Part No	Description
COA-21100	STREET PERFORMANCE, AUTOMATIC, STD. PATTERN
COA-21101	PRO-STREET AUTOMATIC W/ HEAVY DUTY 34 ELEMENT SPRAG, STD. PATTERN
COA-21105	EXTREME STREET AUTOMATIC W/ SUPER SPRAG, 300M ALLOY INPUT SHAFT, STEEL CLUTCH HUB, DEEP ALUMINUM PAN, STD. PATTERN
COA-21110	COMPETITION MANUAL W/ HEAVY DUTY 34 ELEMENT SPRAG, REVERSED PATTERN
COA-21112	COMPETITION MANUAL W/ HEAVY DUTY 34 ELEMENT SPRAG, FORWARD PATTERN WITH ENGINE BRAKING
COA-21120	COMPETITION MANUAL W/ TRANSBRAKE, HEAVY DUTY 34 ELEMENT SPRAG, REVERSED PATTERN
COA-21123	PRO TREE COMPETITION MANUAL W/ INSTANT REACTION TRANSBRAKE, HEAVY DUTY 34 ELEMENT SPRAG, REVERSED PATTERN
COA-21124	EXTREME PERFORMANCE W/ PRO BRAKE, 300M ALLOY INPUT SHAFT, 300M ALLOY MAIN SHAFT, STEEL CLUTCH HUB, SUPER SPRAG, DEEP ALUMINUM PAN, REVERSED PATTERN
COA-21125A	MAXIMUM PERFORMANCE W/ TRANSBRAKE, 300M ALLOY INPUT SHAFT W/ STEEL DRUM, 300M ALLOY MAIN SHAFT, STEEL CLUTCH HUB, BILLET ALUMINUM DIRECT DRUM W/ SUPER SPRAG, DEEP ALUMINUM PAN, STRAIGHT CUT PLANETARY, REVERSED PATTERN
COA-21128	SUPER COMPETITION W/ TRANSBRAKE, HEAVY DUTY 34 ELEMENT SPRAG, 300M ALLOY INPUT SHAFT, STEEL CLUTCH HUB, DEEP ALUMINUM PAN, REVERSED PATTERN

TH400 Components



TH400 Components	
Part No	Description
COA-22010	MANUAL VALVE BODY KIT (REVERSED PATTERN)
COA-22020	TRANSBRAKE KIT (REVERSED PATTERN)
COA-22024	PRO TREE INSTANT REACTION TRANSBRAKE KIT W/ CLEAN NEUTRAL (P-R/N-1-2-3-N), REQUIRES SHIFTER P08-408 OR P08-458 AND BILLET ALUMINUM DIRECT DRUM COA-22814 OR COA-22815
COA-22040	TRANSBRAKE REPLACEMENT SOLENOID
COA-22107	MASTER OVERHAUL KIT, INCLUDES 5 FWD, 5 DIR, 3 INT CLUTCHES, STEELS, GASKETS & RINGS, NO BANDS OR FILTER
COA-22702	MAXIMUM DUTY STRAIGHT CUT PLANETARY, 6 PINION STEEL OUTPUT CARRIER, 2.75 - 1.56 RATIO
COA-22710	MAXIMUM DUTY STRAIGHT CUT PLANETARY, 6 PINION REACTION CARRIER, 4 PINION OUTPUT CARRIER, 2.10 - 1.40 RATIO
COA-22711-186	MAXIMUM DUTY STRAIGHT CUT PLANETARY, 6 PINION REACTION CARRIER, 4 PINION OUTPUT CARRIER, 1.86 - 1.31 RATIO
COA-22711-195	MAXIMUM DUTY STRAIGHT CUT PLANETARY, 6 PINION REACTION CARRIER, 4 PINION OUTPUT CARRIER, 1.95 - 1.34 RATIO
COA-22810	300M ALLOY INPUT SHAFT W/ DRUM, LARGER SPLINES SHAFT TO DRUM
COA-22810A	SUPER SHAFT AEROSPACE ALLOY INPUT SHAFT W/ DRUM, REQUIRES BUSHING IN TORQUE CONVERTER
COA-22811	300M ALLOY MAIN SHAFT, ALSO FITS 4L80E
COA-22812	BILLET STEEL ALLOY FORWARD CLUTCH HUB, ALSO FITS 4L80E
COA-22813	BILLET 7075 ALUMINUM FORWARD DRUM W/ 300M ALLOY INPUT SHAFT
COA-22813A	BILLET 7075 ALUMINUM FORWARD DRUM W/ SUPER SHAFT AEROSPACE ALLOY INPUT SHAFT, REQUIRES BUSHING IN TORQUE CONVERTER
COA-22814	BILLET 7075 ALUMINUM DIRECT DRUM ASSEMBLY W/ 34 ELEMENT SPRAG
COA-22815	BILLET 7075 ALUMINUM DIRECT DRUM ASSEMBLY W/ SUPER SPRAG, 5 CLUTCH INTERMEDIATE, INCLUDES CLUTCHES COA-22230 AND PRESSURE PLATES COA-22818A
COA-22817	DIRECT DRUM ASSY W/ SUPER SPRAG, 5 CLUTCH INTERMEDIATE, INCLUDES CLUTCHES COA-22230 AND PRESSURE PLATES COA-22818A
COA-22819	BILLET ALUMINUM INTERMEDIATE PRESSURE PLATE SUPPORT

TH350 Transmissions

- Automatic, Manual Shift, and Transbrake Valvebodies Available

- 2.52-1.52 Standard Ratio

OPTIONAL COMPONENTS

- Chevrolet or Buick/Olds/Pontiac Case

- 36 Element Intermediate Sprag

- 300M Alloy Shaft
TH or PG Spline

- Billet Aluminum Forward Drum

- Billet Aluminum Direct Drum

- 2.70 Ratio

- Low Volume Pump

- Billet Aluminum Roller Bearing Extension Housing



COA-31120

TH350 Transmissions

Part No	Description
COA-31100	STREET PERFORMANCE AUTOMATIC, STD. PATTERN
COA-31101	PRO-STREET AUTOMATIC W/ HEAVY DUTY 36 ELEMENT SPRAG, STD. PATTERN
COA-31110	COMPETITION MANUAL W/ EXTREME DUTY SPRAG RACE, REVERSED PATTERN
COA-31111	CLASS COMPETITION MANUAL, BILLET ALUMINUM DIRECT DRUM W/ 36 ELEMENT SPRAG, BILLET ALUMINUM FORWARD DRUM, LITE COMPONENTS, REVERSED PATTERN
COA-31112	COMPETITION MANUAL W/ EXTREME DUTY SPRAG RACE, FORWARD PATTERN WITH ENGINE BRAKING
COA-31120	COMPETITION MANUAL W/ TRANSBRAKE, EXTREME DUTY SPRAG RACE, REVERSED PATTERN
COA-31124	EXTREME PERFORMANCE W/ TRANSBRAKE, EXTREME DUTY SPRAG RACE, 36 ELEMENT SPRAG, BILLET ALUMINUM DIRECT DRUM, 5 CLUTCH DIRECT, LIGHTENED SUNSHELL, DEEP ALUMINUM PAN, REVERSED PATTERN
COA-31125	MAXIMUM PERFORMANCE W/ TRANSBRAKE, EXTREME DUTY SPRAG RACE, 36 ELEMENT SPRAG, BILLET ALUMINUM DIRECT DRUM, 5 CLUTCH DIRECT (BLUE), 300M ALLOY INPUT SHAFT, LIGHTENED SUNSHELL, FABRICATED ALUMINUM DEEP PAN, ROLLER BEARING PACKAGE, BILLET ROLLER BEARING EXTENSION HOUSING, REVERSED PATTERN

REBUILD SERVICE

Don't let untimely part failure keep you from reaching the winner's circle. Preventative maintenance is a crucial part of a winning race car. Let the skilled technicians at Coan Engineering keep you on the path to victory by annually performing a freshen-up on your torque converter and transmission. Coan Engineering specializes in rebuilding torque converters and transmissions of any make and model from street performance to racing.

Torque Converters

- Thorough Inspection and Documentation of each Component
- Replace Worn Bushings, Bearings
- Repair, Replace, or Upgrade One-way Clutch/Sprag
- Set Clearances to Coan Exact Tolerances
- Accurately Weld to Ensure Optimum Concentricity
- Dynamic Balance within 5 Grams
- Pressure Check

Transmissions

- Thorough Inspection and Documentation of each Component
- Advise of Potential Performance Enhancements and Upgrades per Application
- Replace or Upgrade All Worn Components
- Accurate Documentation of Customer Information for Future Reference
- Dyno Testing Available
- Valvebody and Solenoid Testing

TH350 Components



TH350 Components

Part No	Description
COA-32010	MANUAL VALVEBODY KIT (REVERSED PATTERN)
COA-32020	TRANSBRAKE KIT (REVERSED PATTERN)
COA-32025	TRANSBRAKE KIT W/ CLEAN NEUTRAL (REVERSED PATTERN P-R/N-1-2-3-N), REQUIRES SHIFTER P08-408 OR P08-458 AND BILLET ALUMINUM DIRECT DRUM COA-32801
COA-32040	TRANSBRAKE REPLACEMENT SOLENOID
COA-32107	MASTER OVERHAUL KIT, INCLUDES 5 FWD, 5 DIR, 3 INT CLUTCHES, STEELS, GASKETS & RINGS, NO BAND OR FILTER
COA-32700	AFTERMARKET PLANETARY, 2.70 - 1.52 RATIO
COA-32801	BILLET 7075 ALUMINUM DIRECT DRUM W/ 36 ELEMENT SPRAG, EXTREME DUTY OUTER RACE
COA-32802	STEEL DIRECT DRUM W/ 36 ELEMENT SPRAG, EXTREME DUTY OUTER RACE
COA-32810	300M ALLOY INPUT SHAFT W/ DRUM, TH SPLINE
COA-32812	BILLET 7075 ALUMINUM FORWARD DRUM W/ OEM INPUT SHAFT, TH SPLINE
COA-32813	BILLET 7075 ALUMINUM FORWARD DRUM W/ 300M ALLOY INPUT SHAFT, TH SPLINE, LARGER SPLINES SHAFT TO DRUM
COA-32832	SUPER PAN KIT, INCLUDES STEF'S FABRICATED DEEP PAN, REAR MOUNT FILTER ADAPTER, FILTER, MOROSO PERM-ALIGN GASKET, HARDWARE
COA-32839A	BILLET ALUMINUM EXTENSION HOUSING W/ ROLLER BEARING (6"), REQUIRES YOKE M05-39035
COA-32892	EXTREME DUTY SPRAG RACE

- Strongest Chrysler 3-Speed for Racing and Street Performance
- Automatic, Manual Shift, and Transbrake Valvebodies Available
- 2.45-1.45 Standard Ratio

OPTIONAL COMPONENTS

- 300M Alloy Input Shaft
- Billet Alloy Forward Hub
- Billet Direct Drum
Aluminum or Steel
- "Super Sprag" 16 Roller Low Sprag
- "Super Support" Rear Support
w/ Bearing
- 5 Pinion Front Planetary

TF727 Transmissions / Components

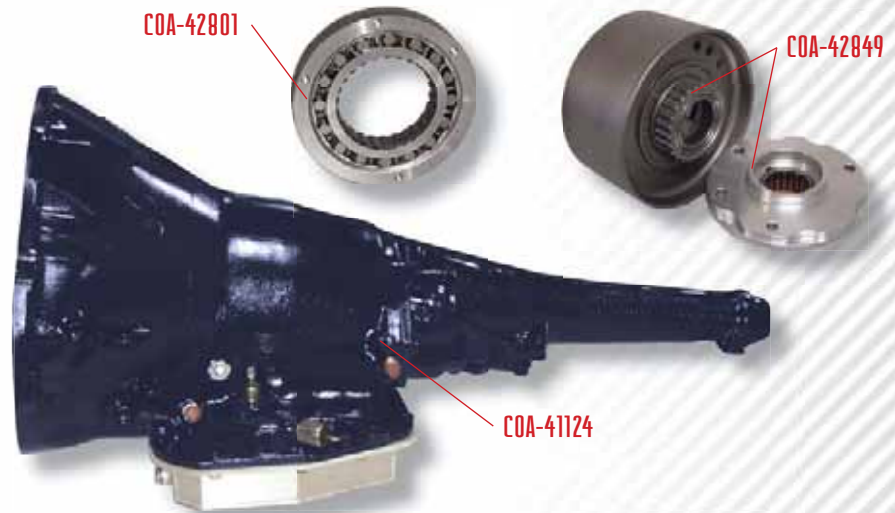

TF727 Transmissions

Part No	Description
COA-41100	STREET PERFORMANCE, AUTOMATIC, STD. PATTERN
COA-41110	COMPETITION MANUAL W/ SUPER SPRAG, REVERSED PATTERN
COA-41123	PRO TREE COMPETITION MANUAL W/ INSTANT REACTON BRAKE, ROLLER BEARING REAR SUPPORT, SUPER SPRAG, BILLET REVERSE SERVO, DEEP ALUMINUM PAN, REVERSED PATTERN
COA-41124	EXTREME PERFORMANCE MEGA MOPAR W/ PRO BRAKE, BILLET ALUMINUM DIRECT DRUM, 6 CLUTCH DIRECT (BLUE), SUPER SUPPORT KIT, 5 PINION FRONT PLANETARY, 16 ROLLER SUPER SPRAG, FABRICATED DEEP PAN, BILLET REVERSE SERVO, BILLET INTERMEDIATE BAND APPLY STRUT, REVERSED PATTERN
COA-41125	MAXIMUM PERFORMANCE MEGA MOPAR W/ PRO BRAKE, 300M ALLOY INPUT SHAFT, BILLET STEEL FWD CLUTCH HUB, BILLET ALUMINUM DIRECT DRUM, 6 CLUTCH DIRECT (BLUE), SUPER SUPPORT KIT, 5 PINION FRONT PLANETARY, 16 ROLLER SUPER SPRAG, FABRICATED DEEP PAN, BILLET INTERMEDIATE SERVO, BILLET REVERSE SERVO, BILLET INTERMEDIATE BAND APPLY STRUT, BILLET WIDE LUG PUMP GEARS, REVERSED PATTERN

TF727 Components

Part No	Description
COA-42010	MANUAL VALVEBODY KIT (REVERSED PATTERN), FITS 727 & 904
COA-42023	PRO TREE TRANSBRAKE KIT (REVERSED PATTERN)
COA-42700	SUPER SET 5 PINION FRONT PLANETARY W/ STEEL CARRIER, INCLUDES RING GEAR MACHINED FOR BEARING, 2.45 RATIO, REQUIRES OUTPUT SHAFT W/ 37.5 DEG PRESSURE ANGLE SPLINES
COA-42801	SUPER SPRAG 16 ROLLER OVERRUN CLUTCH KIT (BOLT-IN), 1966-1989
COA-42808	BILLET STEEL INTERMEDIATE BAND APPLY STRUT
COA-42810	300M ALLOY INPUT SHAFT W/ BILLET STEEL FORWARD CLUTCH HUB (2 RING PUMP)
COA-42815	BILLET 7075 ALUMINUM DIRECT DRUM (INCLUDES BILLET PISTON)
COA-42816	BILLET STEEL DIRECT DRUM (INCLUDES BILLET PISTON)
COA-42849	SUPER SUPPORT KIT, BILLET ALUMINUM REAR SUPPORT, BEARING, AND REVERSE DRUM W/ BEARING

C6 Transmissions

COA-61120

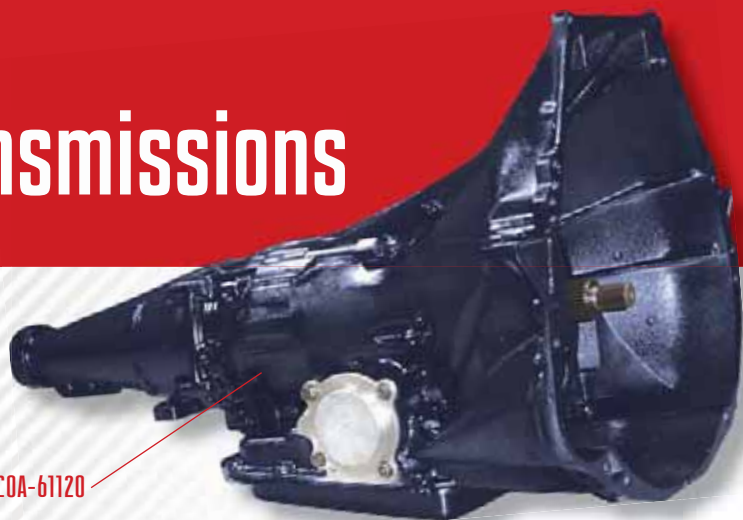

- Automatic, Manual Shift, and Transbrake Valvebodies Available
- Big Block, Small Block, and FE Available

OPTIONAL COMPONENTS

- 300M Alloy Input Shaft
- Billet Intermediate Servo
- 5 Clutch Direct Drum
- Roller Bearing Package

C6 Transmissions

Part No	Description
COA-61100	STREET PERFORMANCE AUTOMATIC W/ BILLET REVERSE SERVO, STD. PATTERN
COA-61110	COMPETITION MANUAL W/ BILLET REVERSE SERVO, REVERSED PATTERN
COA-61120	COMPETITION MANUAL W/ TRANSBRAKE, BILLET SERVO, 5 CLUTCH DRUM, REVERSED PATTERN
COA-61124	EXTREME PERFORMANCE MANUAL W/ TRANSBRAKE, ROLLER BEARING PACKAGE, 300M ALLOY INPUT SHAFT, BILLET SERVO, WIDE BAND, 5 CLUTCH DRUM, FABRICATED PAN, REVERSED PATTERN

C4 Transmissions

COA-71110

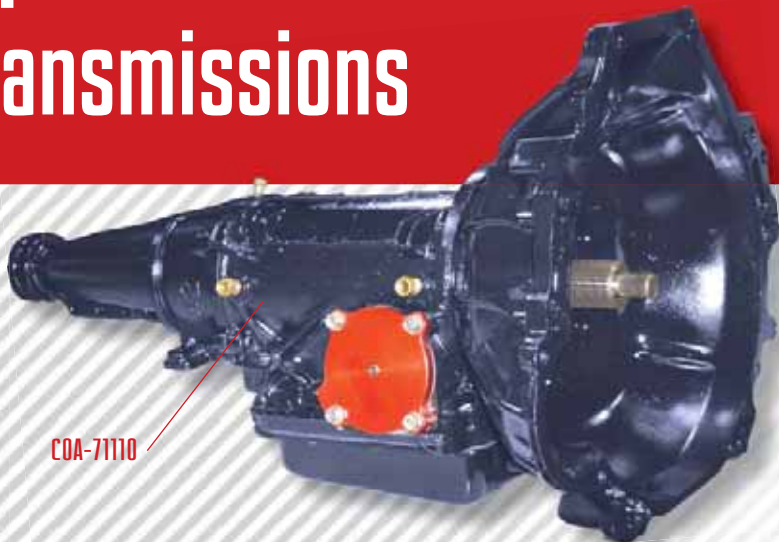

- Automatic, Manual Shift, and Transbrake Valvebodies Available
- Case Fill and Pan Fill Styles Available
- Bellhousings for 164 and 157 Tooth Flexplate

Optional Components

- 300M Alloy Input Shaft
- Billet Steel Forward Drum
- 6 Pinion Front Planetary
- 6 Clutch Direct Drum

C4 Transmissions

Part No	Description
COA-71100	STREET PERFORMANCE AUTOMATIC W/ BILLET SERVO COVER, STD. PATTERN
COA-71110	COMPETITION MANUAL W/ BILLET SERVO COVER, REVERSED PATTERN
COA-71120	COMPETITION MANUAL W/ TRANSBRAKE, 6 DIRECT CLUTCHES (BLUE), BILLET SERVO COVER, DEEP ALUMINUM PAN, REVERSED PATTERN
COA-71124	EXTREME PERFORMANCE MANUAL W/ TRANSBRAKE, 6 DIRECT CLUTCHES (BLUE), HEAVY DUTY FORWARD DRUM, ALLOY INPUT SHAFT, SUPER SET 6 PINION PLANETARY, BILLET SERVO COVER, ROLLER BEARING PACKAGE, DEEP ALUMINUM PAN, REVERSED PATTERN

4L60E / 700-R4 Transmissions

- Most Popular General Motors Overdrive Transmissions
- Perfect Choice for Street Rods
- Heavy Duty Input Drum
- Billet Overdrive Servo Piston
- Heavy Duty Sunshell
- Heavy Duty 3-4 Clutch Pack
- Heavy Duty 29 Element Input Sprag

OPTIONAL COMPONENTS

- 5 Pinion Front Planetary
- 5 Pinion Rear Planetary
- Alloy Output Shaft
- Billet Forward Piston
- Reinforced Input Drum
- Deep Pan



700-R4 Transmissions

Part No	Description
COA-91100	STREET PERFORMANCE AUTOMATIC, HIGH PERFORMANCE SERVO, HIGH PERFORMANCE BAND, HEAVY DUTY 3-4 CLUTCH PACK ('87-UP EXCEPT CORVETTE, 30 SPLINE CONVERTER, SPECIFY ELECTRIC OR MECHANICAL SPEEDOMETER)
COA-91100A	PRO STREET / COMPETITION AUTOMATIC, 5 PINION PLANETARIES, HEAVY DUTY SUNSHELL, BILLET SERVO, SUPER INPUT DRUM, BILLET FORWARD PISTON, HIGH PERFORMANCE BAND, Z-PACK 3-4 CLUTCH PACK ('87-UP EXCEPT CORVETTE, 30 SPLINE CONVERTER, SPECIFY ELECTRIC OR MECHANICAL SPEEDOMETER)

4L60E Transmissions

Part No	Description
COA-111104	STREET PERFORMANCE AUTOMATIC, HIGH PERFORMANCE BAND, HIGH PERFORMANCE 2ND SERVO, BILLET 4TH SERVO, HEAVY DUTY 3-4 CLUTCH PACK, HEAVY DUTY SUNSHELL, SUPER INPUT DRUM
COA-111105	PRO STREET AUTOMATIC, 5 PINION PLANETARIES, HEAVY DUTY SUNSHELL, BILLET SERVO, SUPER INPUT DRUM, HIGH PERFORMANCE BAND, HIGH ENERGY 3-4 CLUTCH PACK
COA-111106	PRO STREET / COMPETITION AUTOMATIC, 5 PINION PLANETARIES, HEAVY DUTY SUNSHELL, BILLET SERVO, SUPER INPUT DRUM, 300M ALLOY OUTPUT SHAFT, HIGH PERFORMANCE BAND, HIGH ENERGY 3-4 CLUTCH PACK

Adapter Kits

- Adapts General Motors Transmissions to a Variety of Engines
- 1/2" Aluminum Plate for Maximum Rigidity
- Plate Dowels to Engine for Precise Alignment
- Transmission Dowels to Plate for Precise Alignment
- Crank Adapter Properly Registers Torque Converter to Crankshaft
- Includes all Necessary Hardware
- Chrysler Models Include SFI Flexplate

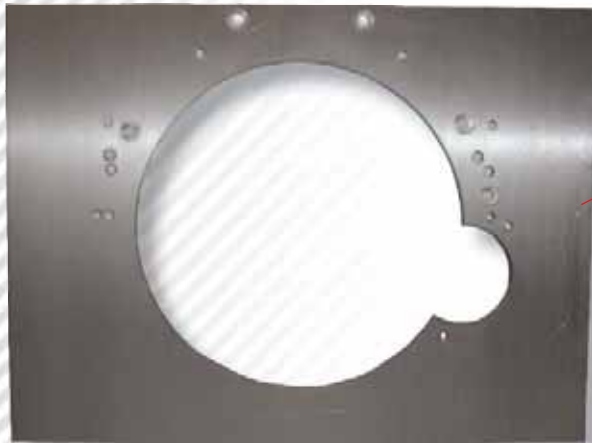

COA-980000

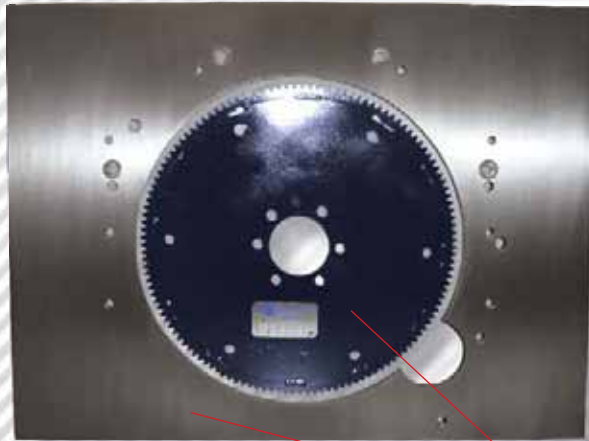

COA-980050
Right Hand Starter



Reactor Flexplates

Part No	
COA-13620	GM 153 Tooth
COA-13621	GM 168 Tooth
COA-13624	GM LS Engine
COA-63605	Ford SB 157 Tooth
COA-63606	Ford SB 164 Tooth
COA-63607	Ford BB 164 Tooth
RO1-130T-8CC	Chrysler 130 Tooth
RO1-168VI-8	Chrysler 168 Tooth

Adapter Kits

Part No	Description
COA-980000	FORD ADAPTER KIT, 289, 302, 351C, 351W, (USE COA-63620 INT BAL, COA-63629 EXT 28.2 OZ, COA-63634 EXT 50 OZ, OR OEM TYPE 157T FLEXPLATE AND STD GM CONVERTER)
COA-980020	FORD ADAPTER KIT, 4.6L, 5.4L, & 6.8L (USE WITH OEM TYPE FLEXPLATE)
COA-980030	FORD ADAPTER KIT, 351M, 400, 429, 460 (SPECIFY PILOT DIAMETER 1.375 OR 1.848, USE OEM TYPE FLEXPLATE AND STD GM CONVERTER)
COA-980040	CHRYSLER ADAPTER KIT, SMALL BLOCK WITH 6 BOLT CRANK (USES +1/4" GM CONVERTER, INCLUDES SFI APPROVED FLEXPLATE AND CRANKSHAFT ADAPTER, SPECIFY START LOCATION)
COA-980050	CHRYSLER ADAPTER KIT, BIG BLOCK WITH 6 BOLT CRANK (USES +1/4" GM CONVERTER, INCLUDES SFI APPROVED FLEXPLATE AND CRANKSHAFT ADAPTER, SPECIFY START LOCATION)
COA-980060	CHRYSLER ADAPTER KIT, BIG BLOCK WITH 8 BOLT CRANK (USES +1/4" GM CONVERTER, INCLUDES SFI APPROVED FLEXPLATE AND CRANKSHAFT ADAPTER, SPECIFY START LOCATION)
COA-980090	'92-'02 V-10 VIPER TO GENERAL MOTORS TRANSMISSION (USES +1/2" GM CONVERTER, INCLUDES SFI APPROVED FLEXPLATE)